



# Georgia Standards of Excellence Curriculum Frameworks

## Mathematics

GSE Geometry

Unit 3: Right Triangle Trigonometry



Richard Woods, Georgia's School Superintendent  
"Educating Georgia's Future"

**Unit 3**  
**Right Triangle Trigonometry**

Table of Contents

OVERVIEW .....	3
STANDARDS ADDRESSED IN THIS UNIT .....	3
STANDARDS FOR MATHEMATICAL PRACTICE .....	4
ENDURING UNDERSTANDINGS .....	4
ESSENTIAL QUESTIONS .....	4
CONCEPTS/SKILLS TO MAINTAIN .....	4
SELECTED TERMS AND SYMBOLS .....	5
Properties, theorems, and corollaries: .....	7
TECHNOLOGY RESOURCES .....	8
EVIDENCE OF LEARNING.....	9
FORMATIVE ASSESSMENT LESSONS (FAL).....	9
SPOTLIGHT TASKS .....	9
3-ACT TASKS .....	9
TASKS .....	10
Horizons (Spotlight Task) .....	12
Formative Assessment Lesson: Proofs of the Pythagorean Theorem.....	26
Pythagorean Triples (Short Cycle Task) .....	28
Eratosthenes Finds the Circumference of the Earth Learning Task .....	30
Discovering Special Triangles Learning Task .....	40
Finding Right Triangles in Your Environment Learning Task.....	52
ACCESS RAMP (Career and Technical Education Task) .....	61
MINIATURE GOLF (Career and Technical Education Task).....	62
RANGE OF MOTION (Career and Technical Education Task).....	63
Create Your Own Triangles Learning Task.....	64
Discovering Trigonometric Ratio Relationships.....	83
Find That Side or Angle .....	88
Formative Assessment Lesson: Right Triangles in Your Environment .....	101
Culminating Task: Clyde’s Construction Crew .....	102
Culminating Task: Hypsometer Activity – Indirect Measurement.....	116

## **OVERVIEW**

In this unit students will:

- explore the relationships that exist between sides and angles of right triangles
- build upon their previous knowledge of similar triangles and of the Pythagorean Theorem to determine the side length ratios in special right triangles
- understand the conceptual basis for the functional ratios sine and cosine
- explore how the values of these trigonometric functions relate in complementary angles
- to use trigonometric ratios to solve problems
- develop the skills and understanding needed for the study of many technical areas
- build a strong foundation for future study of trigonometric functions of real numbers

Although the units in this instructional framework emphasize key standards and big ideas at specific times of the year, routine topics such as estimation, mental computation, and basic computation facts should be addressed on an ongoing basis. Ideas related to the eight practice standards should be addressed constantly as well. This unit provides much needed content information and excellent learning activities. However, the intent of the framework is not to provide a comprehensive resource for the implementation of all standards in the unit. A variety of resources should be utilized to supplement this unit. The tasks in this unit framework illustrate the types of learning activities that should be utilized from a variety of sources. To assure that this unit is taught with the appropriate emphasis, depth, and rigor, it is important that the “**Strategies for Teaching and Learning**” in the Comprehensive Course Overview and the tasks listed under “**Evidence of Learning**” be reviewed early in the planning process.

## **STANDARDS ADDRESSED IN THIS UNIT**

Mathematical standards are interwoven and should be addressed throughout the year in as many different units and activities as possible in order to emphasize the natural connections that exist among mathematical topics.

### **KEY STANDARDS**

Define trigonometric ratios and solve problems involving right triangles.

### **Define trigonometric ratios and solve problems involving right triangles**

**MGSE9-12.G.SRT.6** Understand that by similarity, side ratios in right triangles are properties of the angles in the triangle, leading to definitions of trigonometric ratios for acute angles.

**MGSE9-12.G.SRT.7** Explain and use the relationship between the sine and cosine of complementary angles.

**MGSE9-12.G.SRT.8** Use trigonometric ratios and the Pythagorean Theorem to solve right triangles in applied problems.

## **STANDARDS FOR MATHEMATICAL PRACTICE**

Refer to the Comprehensive Course Overview for more detailed information about the Standards for Mathematical Practice.

1. Make sense of problems and persevere in solving them.
2. Reason abstractly and quantitatively.
3. Construct viable arguments and critique the reasoning of others.
4. Model with mathematics.
5. Use appropriate tools strategically.
6. Attend to precision.
7. Look for and make use of structure.
8. Look for and express regularity in repeated reasoning.

*SMP = Standards for Mathematical Practice*

## **ENDURING UNDERSTANDINGS**

- Similar right triangles produce trigonometric ratios.
- Trigonometric ratios are dependent only on angle measure.
- Trigonometric ratios can be used to solve application problems involving right triangles.

## **ESSENTIAL QUESTIONS**

- What is the Pythagorean Theorem, and when is this theorem used?
- How are the sides and angles of right triangles related to each other?
- How can right triangle relationships be used to solve practical problems?

## **CONCEPTS/SKILLS TO MAINTAIN**

It is expected that students will have prior knowledge/experience related to the concepts and skills identified below. It may be necessary to pre-assess in order to determine if time needs to be spent on conceptual activities that help students develop a deeper understanding of these ideas.

- number sense
- computation with whole numbers, integers and irrational numbers, including application of order of operations
- operations with algebraic expressions
- simplification of radicals
- basic geometric constructions
- properties of parallel and perpendicular lines
- applications of Pythagorean Theorem
- properties of triangles, quadrilaterals, and other polygons
- ratios and properties of similar figures
- properties of triangles

### **SELECTED TERMS AND SYMBOLS**

According to Dr. Paul J. Riccomini, Associate Professor at Penn State University,



*“When vocabulary is not made a regular part of math class, we are indirectly saying it **isn’t important!**”* (Riccomini, 2008) Mathematical vocabulary can have significant positive and/or negative impact on students’ mathematical performance.

- ⊙ Require students to use mathematically correct terms.
- ⊙ Teachers must use mathematically correct terms.
- ⊙ Classroom tests must regularly include math vocabulary.
- ⊙ Instructional time must be devoted to mathematical vocabulary.

<http://www.nasd.k12.pa.us/pubs/SpecialED/PDEConference/Handout%20Riccomini%20Enhancing%20Math%20InstructionPP.pdf>

For help in teaching vocabulary, a Frayer model can be used. The following is an example of a term from earlier grades. <http://wvde.state.wv.us/strategybank/FrayerModel.html>

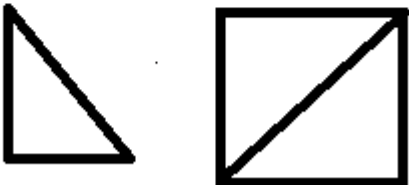
# Frayer Model

<p><b>Definition in your own words</b></p> <p>A right triangle is a triangle in which one of the interior angles is a right angle.</p>	<p><b>Facts/characteristics</b></p> <p>Each of the non-right angles in a right triangle is an acute angle.                  The acute angles in a right triangle are complementary.                  The side of a right triangle opposite the <math>90^\circ</math> angle is called the hypotenuse; each of the other sides is called a leg.</p>
<p><b>Right Triangle</b></p>	
<p><b>Examples</b></p> 	<p><b>Nonexamples</b></p> 

More explanations and examples can be found at <http://oame.on.ca/main/files/thinklil/FrayerModel.pdf>

The following terms and symbols are often misunderstood. Students should explore these concepts using models and real-life examples. Students should understand the concepts involved and be able to recognize and/or demonstrate them with words, models, pictures, or numbers.

- **Adjacent side:** In a right triangle, for each acute angle in the interior of the triangle, one ray forming the acute angle contains one of the legs of the triangle and the other ray contains the hypotenuse. This leg on one ray forming the angle is called the adjacent side of the acute angle.

For any acute angle in a right triangle, we denote the measure of the angle by  $\theta$  and define three numbers related to  $\theta$  as follows:

$$\text{sine of } \theta = \sin(\theta) = \frac{\text{length of opposite side}}{\text{length of hypotenuse}}$$

$$\text{cosine of } \theta = \cos(\theta) = \frac{\text{length of adjacent side}}{\text{length of hypotenuse}}$$

$$\text{tangent of } \theta = \tan(\theta) = \frac{\text{length of opposite side}}{\text{length of adjacent side}}$$

- **Angle of Depression:** The angle below horizontal that an observer must look to see an object that is lower than the observer. Note: The angle of depression is congruent to the angle of elevation (this assumes the object is close enough to the observer so that the horizontals for the observer and the object are effectively parallel; this would not be the case for an astronaut in orbit around the earth observing an object on the ground).
- **Angle of Elevation:** The angle above horizontal that an observer must look to see an object that is higher than the observer. Note: The angle of elevation is congruent to the angle of depression (this assumes the object is close enough to the observer so that the horizontals for the observer and the object are effectively parallel; this would not be the case for a ground tracking station observing a satellite in orbit around the earth).
- **Complementary angles:** Two angles whose sum is  $90^\circ$  are called **complementary**. Each angle is called the complement of the other.
- **Opposite side:** In a right triangle, the side of the triangle opposite the vertex of an acute angle is called the opposite side relative to that acute angle.
- **Similar triangles:** Triangles are similar if they have the same shape but not necessarily the same size.

- Triangles whose corresponding angles are congruent are similar.
- Corresponding sides of similar triangles are all in the same proportion.
- Thus, for the similar triangles shown at the right with angles A, B, and C congruent to angles A', B', and C' respectively, we have that:, we have that:

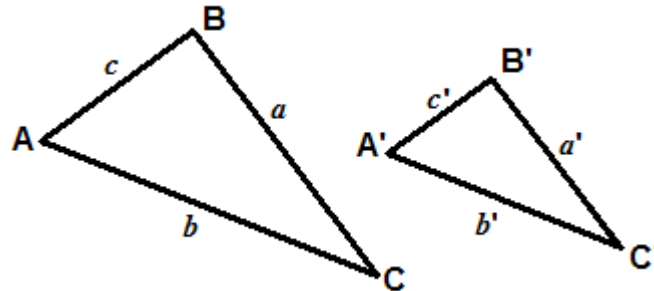

$$\frac{a}{a'} = \frac{b}{b'} = \frac{c}{c'}$$

### Properties, theorems, and corollaries:

- For the **similar triangles**, as shown above, with angles A, B, and C congruent to angles A', B', and C' respectively, the following proportions follow from the proportion between the triangles.

$$\frac{a}{a'} = \frac{b}{b'} \quad \text{if and only if} \quad \frac{a}{b} = \frac{a'}{b'}; \quad \frac{a}{a'} = \frac{c}{c'} \quad \text{if and only if} \quad \frac{a}{c} = \frac{a'}{c'};$$

$$\text{and } \frac{b}{b'} = \frac{c}{c'} \quad \text{if and only if } \frac{b}{c} = \frac{b'}{c'}.$$

Three separate equalities are required for these equalities of ratios of side lengths in one triangle to the corresponding ratio of side lengths in the similar triangle because, in general, these are three different ratios. The general statement is that the ratio of the lengths of two sides of a triangle is the same as the ratio of the corresponding sides of any similar triangle.

- For each pair of complementary angles in a right triangle, the sine of one angle is the cosine of its complement.

This web site has activities to help students more fully understand and retain new vocabulary (i.e. the definition page for *dice* actually generates rolls of the dice and gives students an opportunity to add them).

<http://www.amathsdictionaryforkids.com/>

Definitions and activities for these and other terms can be found on the InterMath website <http://intermath.coe.uga.edu/dictionary/homepg.asp>.

## **TECHNOLOGY RESOURCES**

- Review of right triangles and Pythagorean Theorem: [http://real.doe.k12.ga.us/content/math/destination\\_math/MSC5/msc5/msc5/msc5/MSC5/Module3/Unit1/Session1/Tutorial.html?USERID=0&ASSIGNID=0](http://real.doe.k12.ga.us/content/math/destination_math/MSC5/msc5/msc5/msc5/MSC5/Module3/Unit1/Session1/Tutorial.html?USERID=0&ASSIGNID=0)
- Right Triangle Relationships: <http://illuminations.nctm.org/LessonDetail.aspx?id=L684>
- Lesson on sines: <http://brightstorm.com/math/geometry/basic-trigonometry/trigonometric-ratios-sine/>
- Lesson on cosines: <http://brightstorm.com/math/geometry/basic-trigonometry/trigonometric-ratios-cosine/>
- Lesson on Right Triangle Trigonometry: <http://www.khanacademy.org/video/basic-trigonometry?playlist=Trigonometry>
- Review of Special Right Triangles (formative assessment lesson): <http://www.map.mathshell.org/materials/download.php?fileid=696>



## **EVIDENCE OF LEARNING**

By the conclusion of this unit, students should be able to demonstrate the following competencies:

- Make connections between the angles and sides of right triangles
- Select appropriate trigonometric functions to find the angles/sides of a right triangle
- Use right triangle trigonometry to solve realistic problems

## **FORMATIVE ASSESSMENT LESSONS (FAL)**

**Formative Assessment Lessons** are intended to support teachers in formative assessment. They reveal and develop students' understanding of key mathematical ideas and applications. These lessons enable teachers and students to monitor in more detail their progress towards the targets of the standards. They assess students' understanding of important concepts and problem solving performance, and help teachers and their students to work effectively together to move each student's mathematical reasoning forward.

More information on Formative Assessment Lessons may be found in the Comprehensive Course Overview.

## **SPOTLIGHT TASKS**

A Spotlight Task has been added to each GSE mathematics unit in the Georgia resources for middle and high school. The Spotlight Tasks serve as exemplars for the use of the Standards for Mathematical Practice, appropriate unit-level Georgia Standards of Excellence, and research-based pedagogical strategies for instruction and engagement. Each task includes teacher commentary and support for classroom implementation. Some of the Spotlight Tasks are revisions of existing Georgia tasks and some are newly created. Additionally, some of the Spotlight Tasks are 3-Act Tasks based on 3-Act Problems from Dan Meyer and Problem-Based Learning from Robert Kaplinsky.

## **3-ACT TASKS**

A Three-Act Task is a whole group mathematics task consisting of 3 distinct parts: an engaging and perplexing Act One, an information and solution seeking Act Two, and a solution discussion and solution revealing Act Three.

More information along with guidelines for 3-Act Tasks may be found in the Comprehensive Course Overview.

## **TASKS**

The following tasks represent the level of depth, rigor, and complexity expected of all Geometry students. These tasks, or tasks of similar depth and rigor, should be used to demonstrate evidence of learning. It is important that all elements of a task be addressed throughout the learning process so that students understand what is expected of them. While some tasks are identified as a performance task, they may also be used for teaching and learning (learning/scaffolding task).

<b>Task Name</b>	<b>Task Type Grouping Strategy</b>	<b>Content Addressed</b>	<b>SMPs Addressed</b>
Horizons (Spotlight Task)	Scaffolding Task <i>Individual/Partner Task</i>	Pythagorean Theorem	1, 4, 5
Proofs of the Pythagorean Theorem (FAL)	Formative Assessment Lesson	Pythagorean Theorem	3, 7
Pythagorean Triples	Short Cycle Task	Pythagorean Theorem	2, 3, 6, 7
Eratosthenes Finds the Circumference of the Earth	Enrichment Learning Task <i>Small Group/Whole Group Task</i>	Triangles in a Circular Context	2, 6, 7, 8
Discovering Special Triangles	Learning Task <i>Small Group Task</i>	45-45-90 and 30-60-90 Triangles	2, 6, 7, 8
Finding Right Triangles in Your Environment	Learning Task <i>Partner/Small Group Task</i>	Applications of Right Triangles	1 – 8
Access Ramp	Achieve CCSS- CTE Classroom Tasks	Applications of Right Triangles	1 – 8
Miniature Golf	Achieve CCSS- CTE Classroom Tasks	Applications of Right Triangles	1 – 8
Range of Motion	Achieve CCSS- CTE Classroom Tasks	Applications of Right Triangles	1 – 8
Create Your Own Triangles	Learning Task <i>Individual/Partner Task</i>	Complementary Relationships	1 – 8
Triangular Frameworks	Short Cycle Task	Complementary Relationships	1 – 6
Discovering Trigonometric Ratio Relationships	Learning Task <i>Individual/Small Group Task</i>	Trigonometric Ratios	2, 3
Find That Side or Angle	Learning Task <i>Partner/Group Task</i>	Inverses of trigonometric functions	1, 4, 5

## Georgia Department of Education

Georgia Standards of Excellence Framework

*GSE Geometry • Unit 3*

Right Triangles in Your Environment (FAL)	Formative Assessment Lesson	Finding sides and angles of right triangles	1, 3, 4, 6
Clyde's Construction Crew	Culminating Task/Assessment <i>Partner/Small Group Task</i>	Review of Unit Standards	1 – 8
Hypsometer Activity	Culminating Task/Assessment <i>Partner/Small Group Task</i>	Review of Unit Standards	1 – 8

## Horizons (Spotlight Task)

*More information along with guidelines for 3-Act Tasks may be found in the Comprehensive Course Overview.*

*Given Internet connection or video capabilities, use the first student version of the task. If no Internet connection or video capabilities, use the Horizons Student version following this task, which contains images rather than video. It is highly suggested that you use the video version in order to support students in imagining the situation.*

### Standards Addressed in this Task

**MGSE9-12.G.SRT.8** Use trigonometric ratios and the Pythagorean Theorem to solve right triangles in applied problems.

### Standards for Mathematical Practice

**1. Make sense of problems and persevere in solving them** by requiring students to interpret and make meaning of a problem and find a logical starting point, and to monitor their progress and change their approach to solving the problem, if necessary.

**4. Model with mathematics** by expecting students to apply the mathematics concepts they know in order to solve problems arising in everyday situations, and reflect on whether the results are sensible for the given scenario.

**5. Use appropriate tools strategically** by expecting students to consider available tools when solving a mathematical problem. These tools might include pencil and paper, concrete models, a ruler, a protractor, a compass, a calculator, software, etc.

### Student Misconceptions

1. Some students believe that right triangles must be oriented a particular way.
2. Some students do not realize that opposite and adjacent sides need to be identified with reference to a particular acute angle in a right triangle.

## Act I

*Have students watch the video at the following link. Once watched, have the students discuss questions that they might ask about the situation (e.g., how tall is the ride, how long is the ride, how fast do they go, etc.). You might use a think-pair-share set up followed by reporting out. Keep a running tab of the questions that students generate, preferably on the whiteboard. If not posed, introduce, “How far can we see?” as the focal question. Leave the video playing on loop for them to watch and analyze.*

Watch the presented video, which can be found at:  
<https://www.youtube.com/watch?v=eTK6aDcQ0PA>

or at: <http://real.doe.k12.ga.us/vod/gso/math/Ride.mp4>

## Act II

*With the focal question introduced, have students work in groups pursuing their questions and the focal question. Write, “What information do you need?” on the board and remind them they should be asking this as they go along. Those teachers with classroom computers can have their students working from computers to answer (and keep track of) the information they need. Those without Internet can provide information to the students as they ask. It is key that students are generating the questions and thinking about the information they need. The most relevant information is:*

*Ride Height: 335 ft.*

*Drop: 310 ft.*

*G-force: 3.5 G.*

*Duration: Approx. 2:00 min.*

*800 riders per hour*

*Height restriction: 54 inch*

*32 seats into 8 rows of 4.*

*Variable hold time at the top.*

*5-6 seconds of freefall time*

*6,000 bolts to tie all of it together.*

*Top speed: Approximately 60mph*

*Radius of earth: 3963 miles converted to feet is  $3963 \text{ miles} \times 5280 \text{ feet/mile} = 20,924,640 \text{ feet}$ .*

As you work on your problems, think about and determine what information you need.

## Act III

*While no technical video reveal is done, the following pictures can be used to show the viewing radius and give some sense of visible scale with the tilted pictures. Visibility is 118404 feet or 22.4251 miles.*

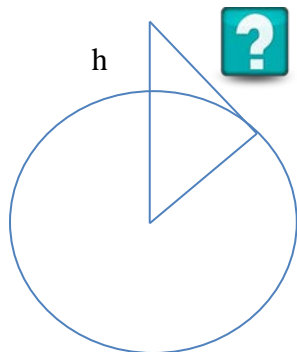

*The following questions can be used as extension questions.*

**Georgia Department of Education**  
Georgia Standards of Excellence Framework  
*GSE Geometry • Unit 3*

1. Imagine the Falcon's Fury was put on Mars. How far could you see from the top of the ride on Mars?
2. Imagine the Falcon's Fury was put on a planet with a radius twice the size of the Earth. How far could you see from the top of the ride on that planet?
3. Jupiter's radius is 11.2 times larger than the Earth's. How far could you see from the top of the ride on Jupiter?

Your homework assignment is to find how far you can see if you were viewing from the top of:

1. A building in Atlanta [i.e., Westin Peachtree Plaza, the state capital building, AT&T Tower (Promenade Center), etc.]
2. A building in your home city.
3. Acrophobia at Six Flags Over Georgia.
4. A building in another country.

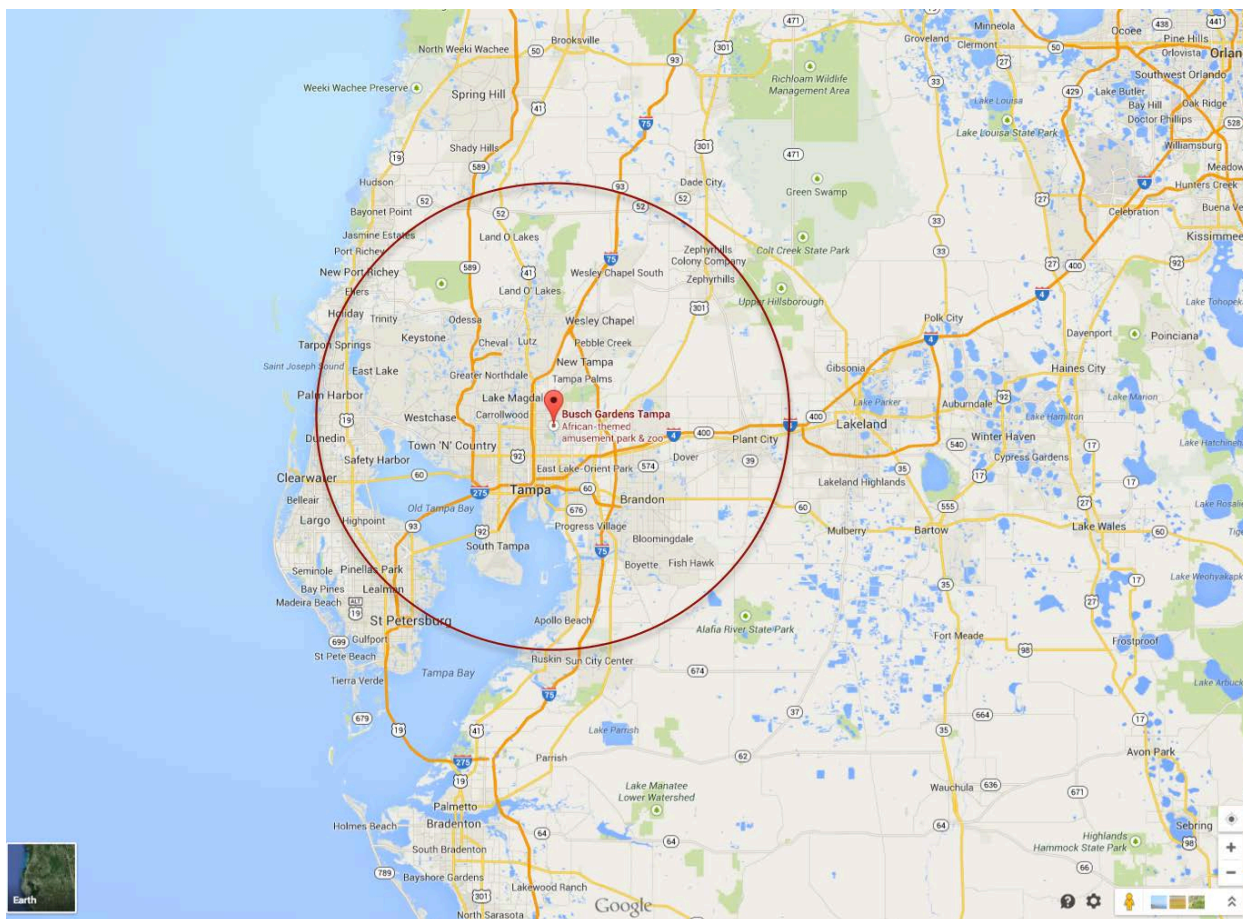



**Georgia Department of Education**  
Georgia Standards of Excellence Framework  
*GSE Geometry • Unit 3*

**Looking North**

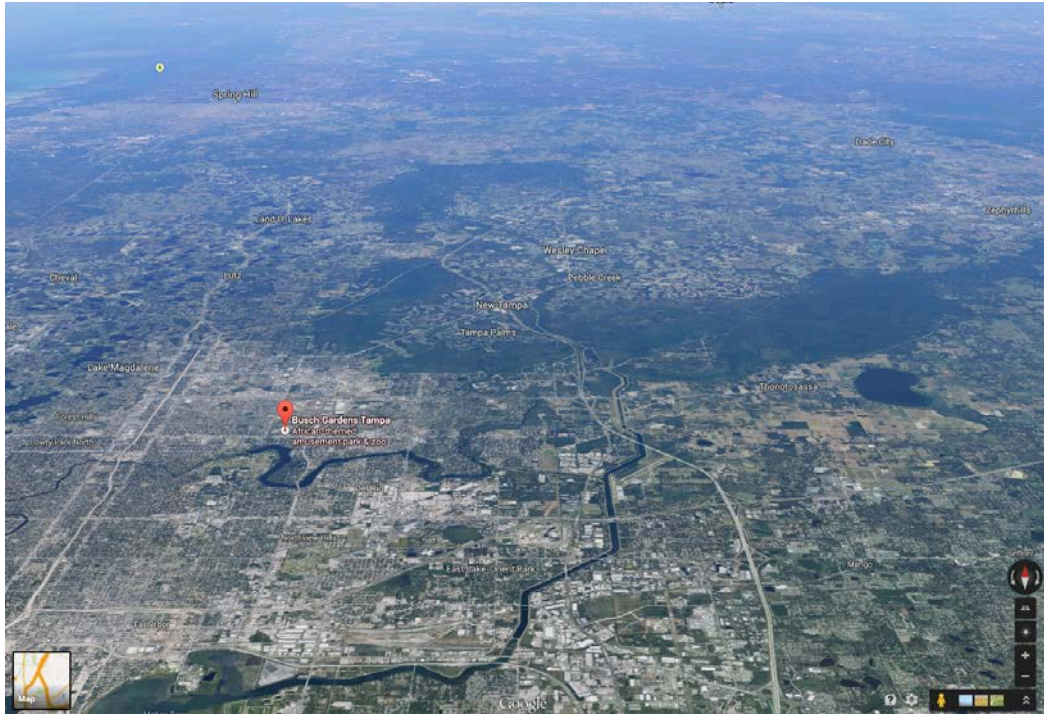

**Looking East**

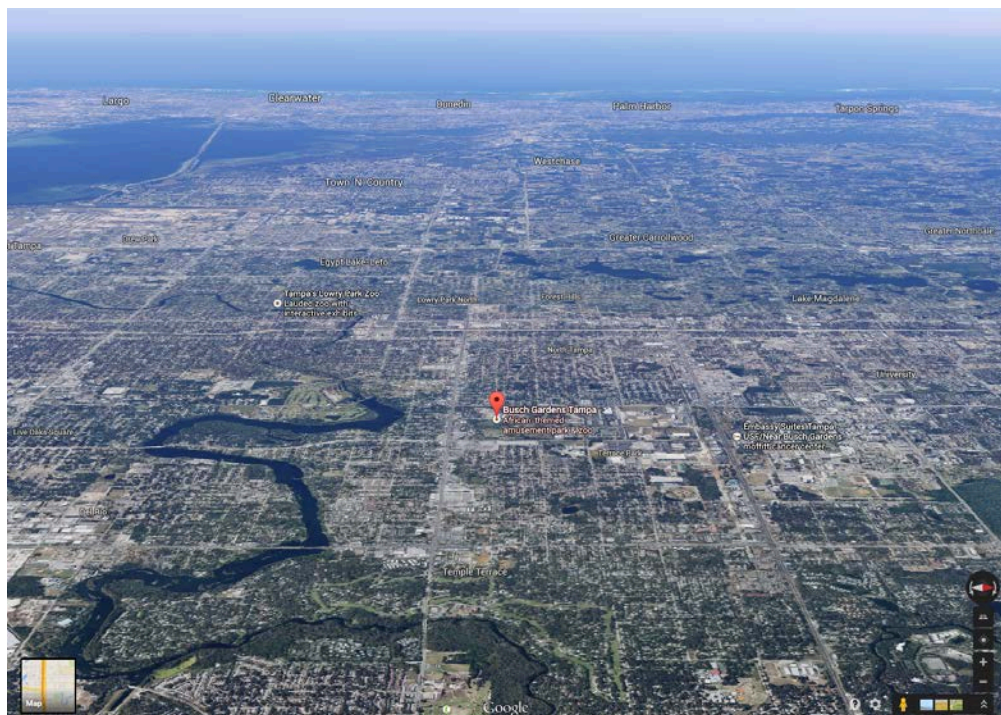

## Horizons (Spotlight Task)

### Act I

Watch the presented video, which can be found at:  
<https://www.youtube.com/watch?v=eTK6aDcQ0PA>

### Act II

As you work on your problems, think about and determine what information you need.

### Act III

1. Imagine the Falcon's Fury was put on Mars. How far could you see from the top of the ride on Mars?
2. Imagine the Falcon's Fury was put on a planet with a radius twice the size of the Earth. How far could you see from the top of the ride on that planet?
3. Jupiter's radius is 11.2 times larger than the Earth's. How far could you see from the top of the ride on Jupiter?

Your homework assignment is to find how far you can see if you were viewing from the top of:

1. A building in Atlanta [i.e., Westin Peachtree Plaza, the state capital building, AT&T Tower (Promenade Center), etc.]
2. A building in your home city.
3. Acrophobia at Six Flags Over Georgia.
4. A building in another country.



**Georgia Department of Education**  
Georgia Standards of Excellence Framework  
*GSE Geometry • Unit 3*

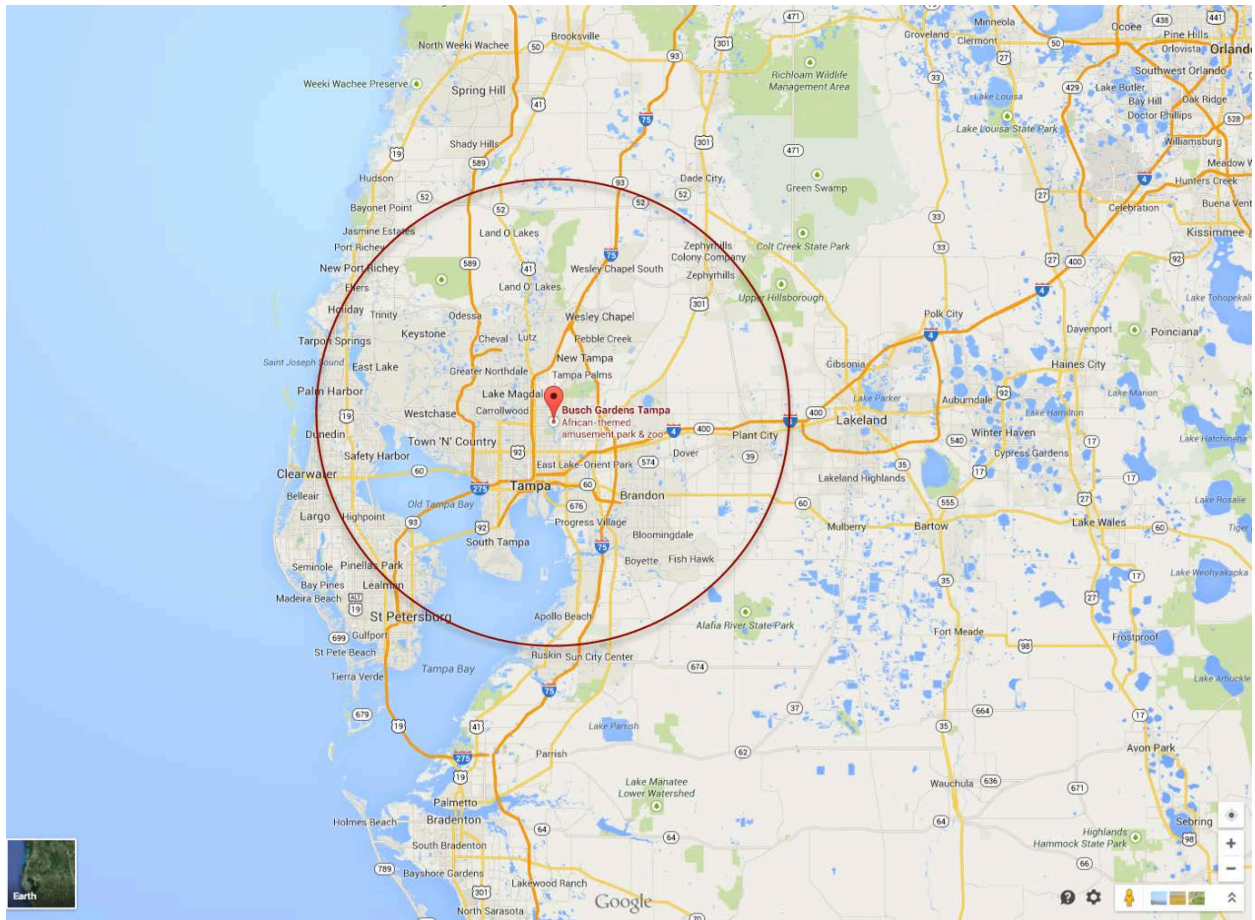

**Georgia Department of Education**  
Georgia Standards of Excellence Framework  
*GSE Geometry • Unit 3*

**Looking North**

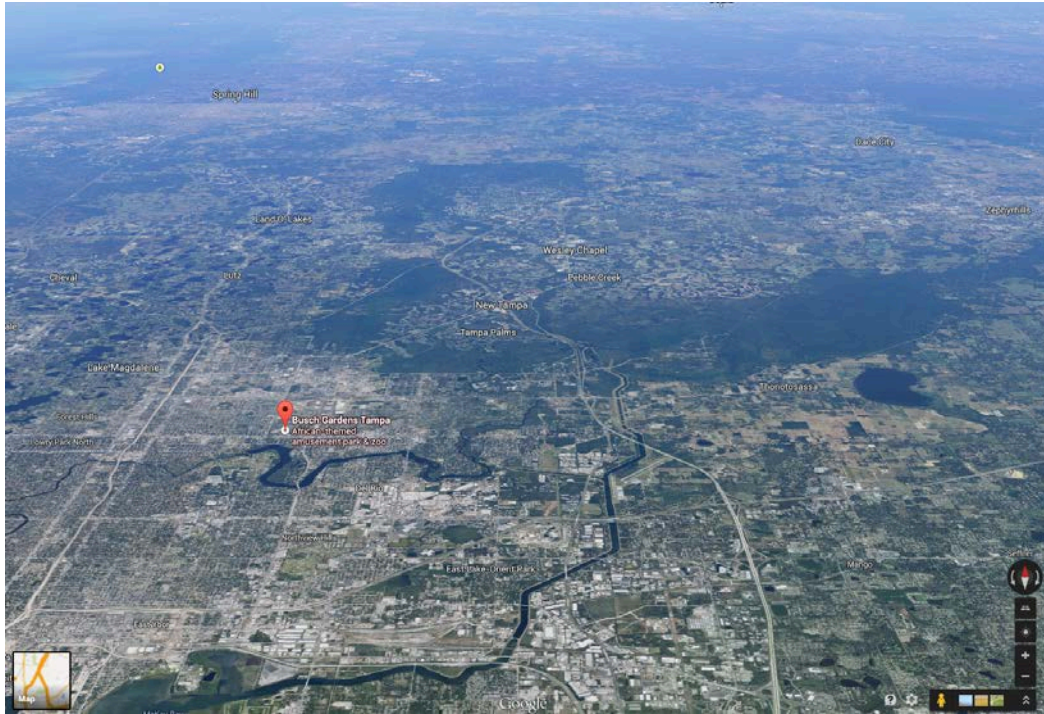

**Looking East**

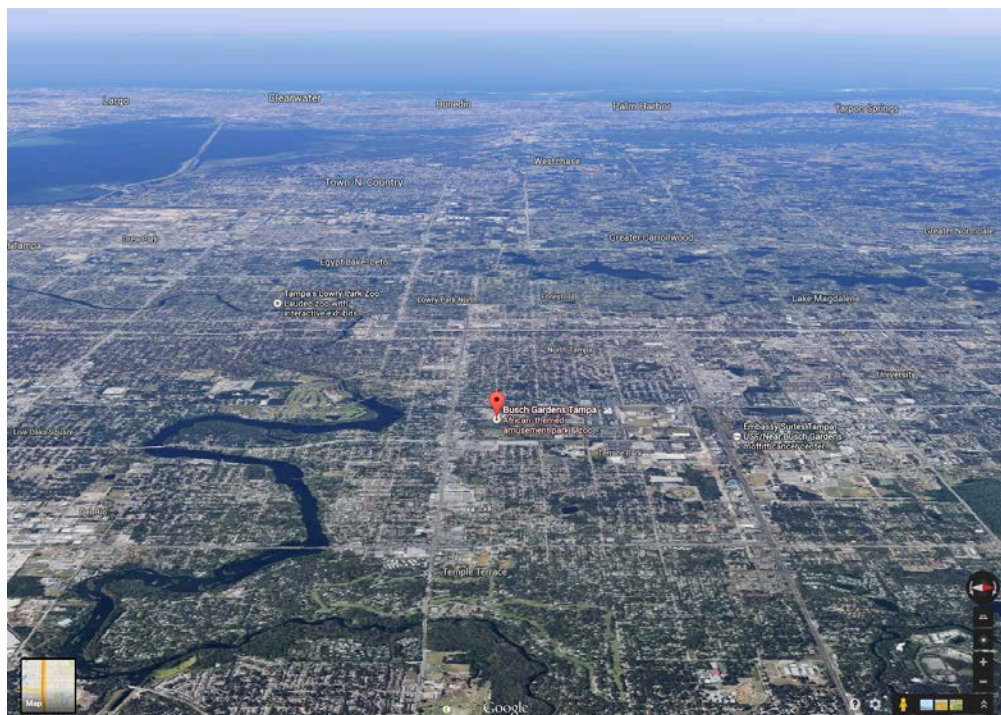



## **Horizons (with screen shots)**

### **Act I**

Below you will find pictures taken in sequence while an individual rides Falcon's Fury, an amusement park ride at Busch Gardens in Tampa, FL. After raising you to the top of the ride, the seats tilt so you are facing the ground. The ride then drops you toward the ground before returning you to your original seated position.



**Georgia Department of Education**  
Georgia Standards of Excellence Framework  
*GSE Geometry • Unit 3*





**Georgia Department of Education**  
Georgia Standards of Excellence Framework  
*GSE Geometry • Unit 3*

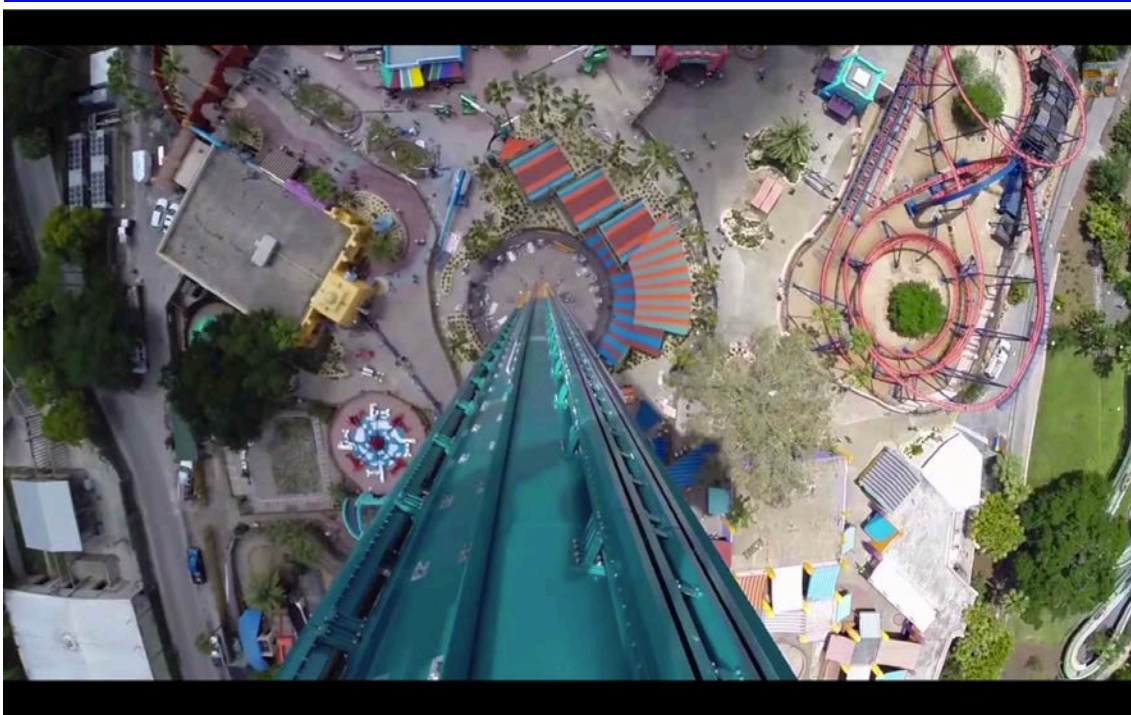



**Georgia Department of Education**  
Georgia Standards of Excellence Framework  
*GSE Geometry • Unit 3*



## Act II

As you work on your problems, think about and determine what information you need.

## Act III

1. Imagine the Falcon's Fury was put on Mars. How far could you see from the top of the ride on Mars?
2. Imagine the Falcon's Fury was put on a planet with a radius twice the size of the Earth. How far could you see from the top of the ride on that planet?
3. Jupiter's radius is 11.2 times larger than the Earth's. How far could you see from the top of the ride on Jupiter?

Your homework assignment is to find how far you can see if you were viewing from the top of:

5. A building in Atlanta [i.e., Westin Peachtree Plaza, the state capital building, AT&T Tower (Promenade Center), etc.]
6. A building in your home city.
7. Acrophobia at Six Flags Over Georgia.
8. A building in another country.

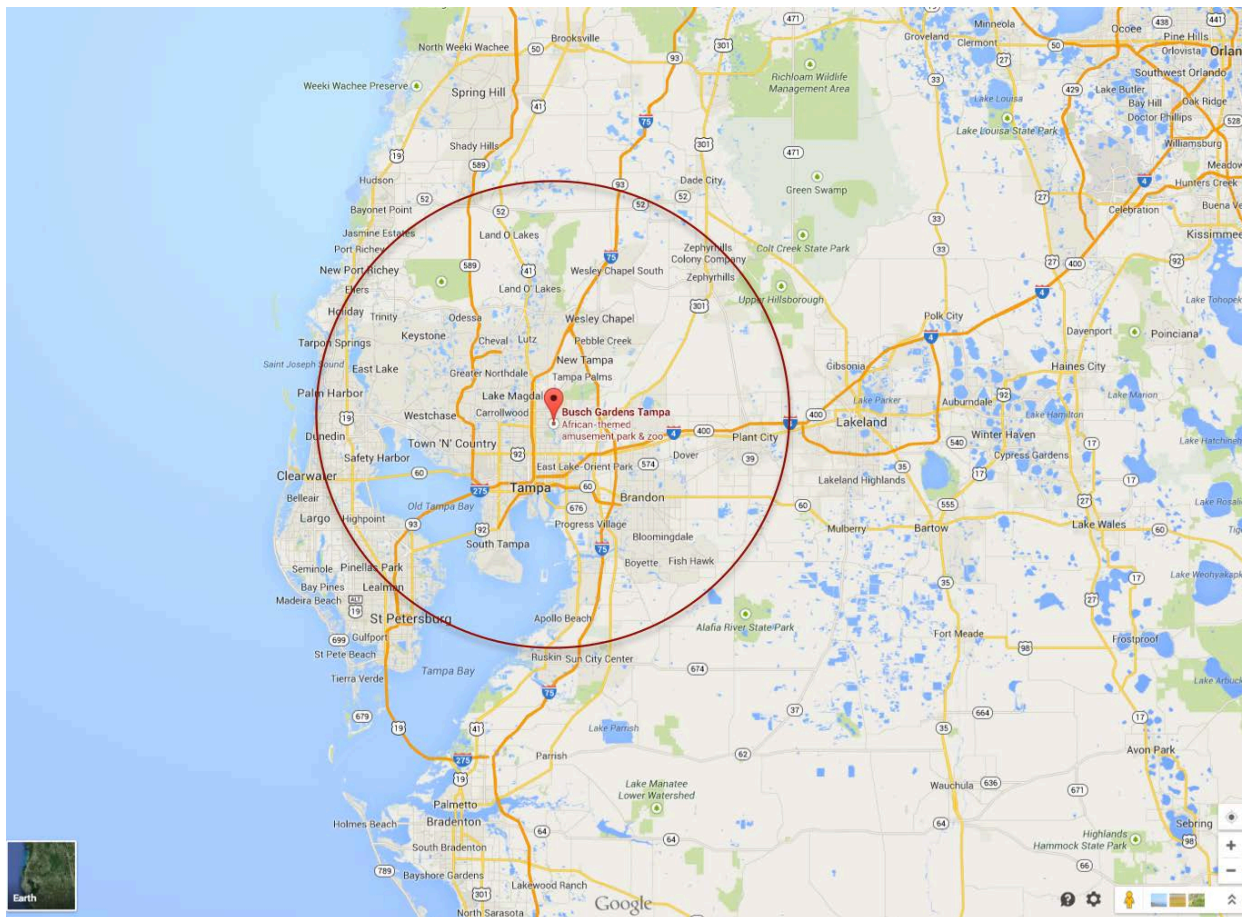



## Looking North

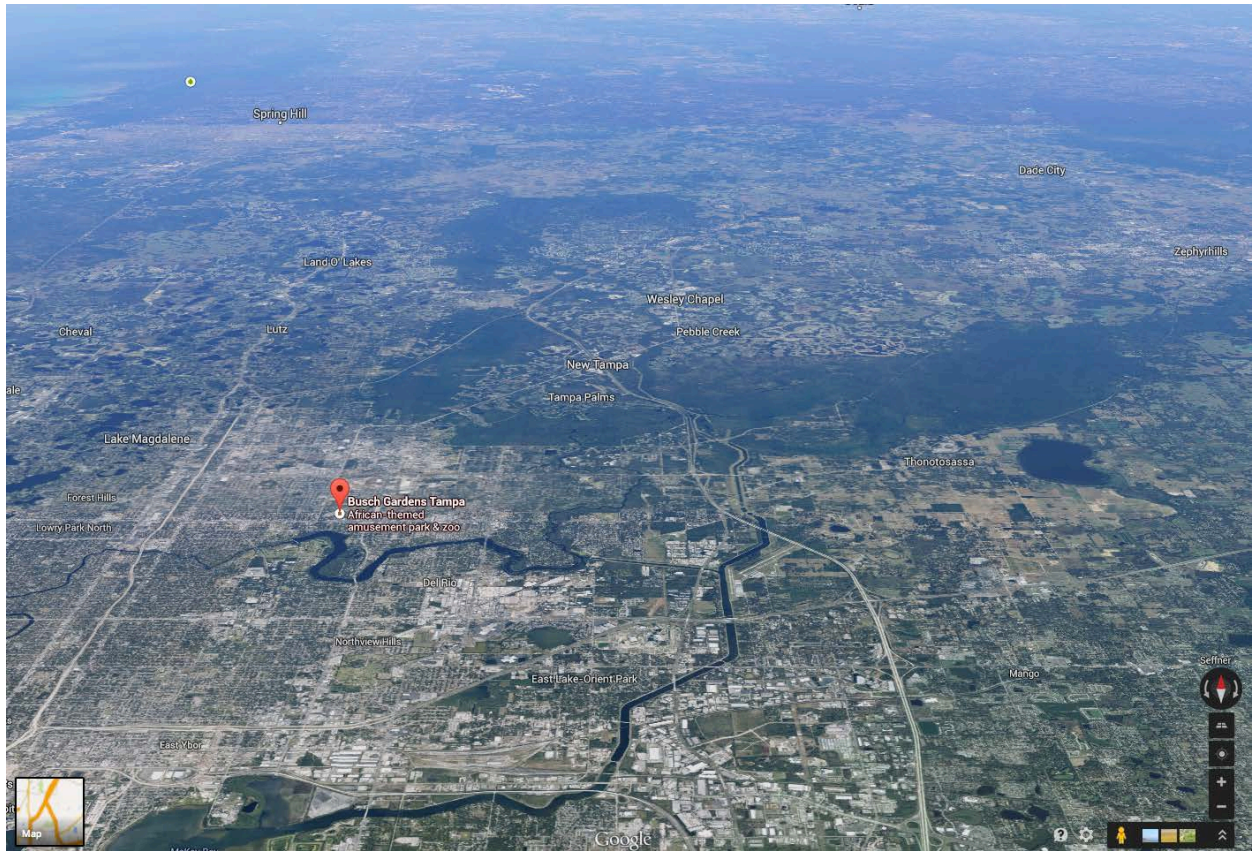



**Georgia Department of Education**  
Georgia Standards of Excellence Framework  
*GSE Geometry • Unit 3*

**Looking East**

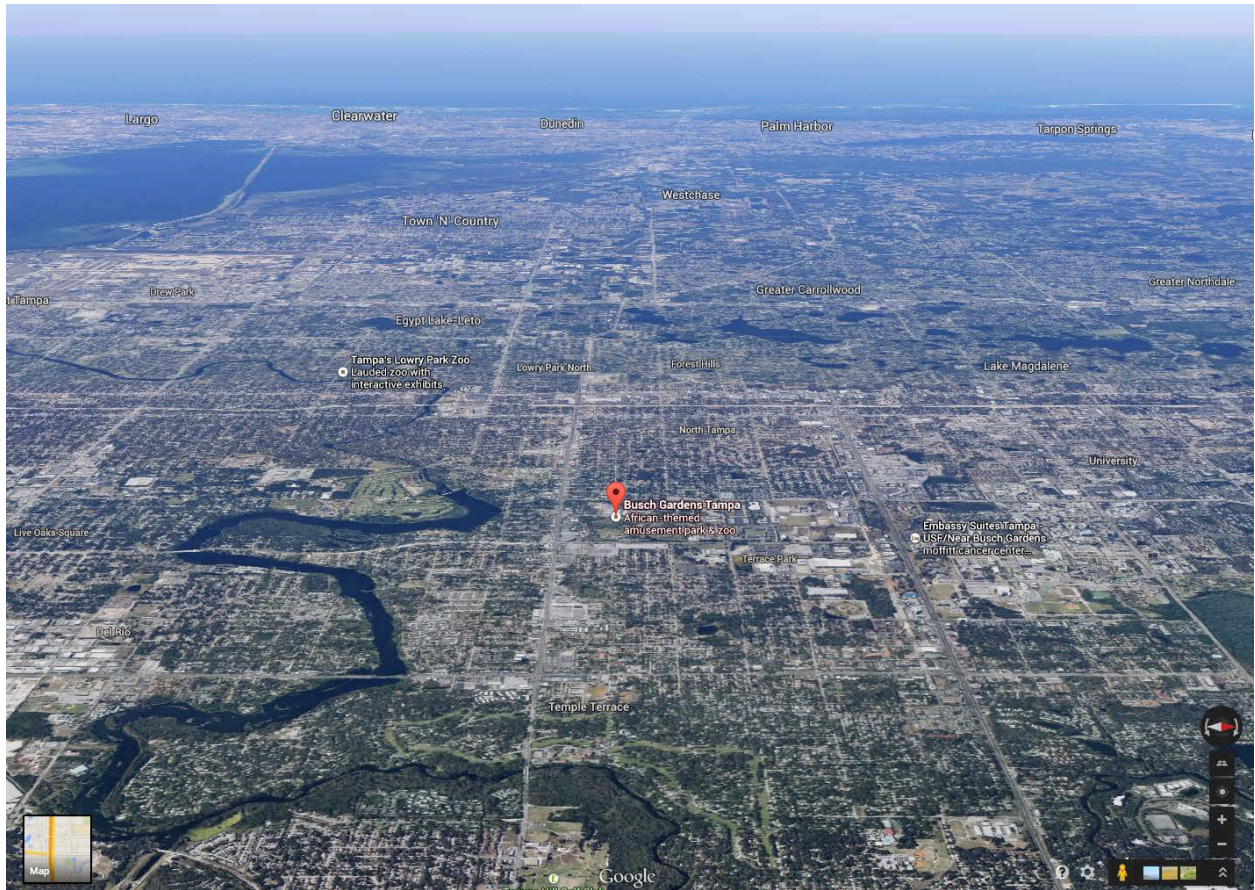

## Formative Assessment Lesson: Proofs of the Pythagorean Theorem

Source: *Formative Assessment Lesson Materials from Mathematics Assessment Project*

<http://map.mathshell.org/materials/download.php?fileid=1231>

### **ESSENTIAL QUESTIONS**

- After interpreting a diagram, how do you identify mathematical knowledge relevant to an argument?
- How do you link visual and algebraic representations?
- How do you produce and evaluate mathematical arguments?

### **TASK COMMENTS:**

Tasks and lessons from the Mathematics Assessment Project are specifically designed to help teachers effectively formatively assess their students. The way the tasks and lessons are designed gives the teacher a clear understanding of what the students are able to do and not do. Within the lesson, teachers will find suggestions and question prompts that will help guide students towards understanding. For more information access the MAP website:

<http://www.map.mathshell.org/materials/background.php?subpage=formative>

The task, *Proofs of the Pythagorean Theorem*, is a Formative Assessment Lesson (FAL) that can be found at the

website: <http://map.mathshell.org/materials/lessons.php?taskid=419&subpage=concept>

The FAL document provides a clear lesson design, from the opening of the lesson to the closing of the lesson.

The PDF version of the task can be found at the link below:

<http://map.mathshell.org/materials/download.php?fileid=1231>

### **STANDARDS ADDRESSED IN THIS TASK:**

#### **Define trigonometric ratios and solve problems involving right triangles**

**MGSE9-12.G.SRT.6** Understand that by similarity, side ratios in right triangles are properties of the angles in the triangle, leading to definitions of trigonometric ratios for acute angles.

**MGSE9-12.G.SRT.7** Explain and use the relationship between the sine and cosine of complementary angles.

**MGSE9-12.G.SRT.8** Use trigonometric ratios and the Pythagorean Theorem to solve right triangles in applied problems.

#### **Standards for Mathematical Practice**

This lesson uses all of the practices with emphasis on:

**3. Construct viable arguments and critique the reasoning of others** by engaging students on discussion of why they agree or disagree with responses, decide whether they make sense, and ask useful questions to clarify or improve the arguments.

**7. Look for and make use of structure** by expecting students to apply rules, look for patterns and analyze structure.

## Pythagorean Triples (Short Cycle Task)

Source: *Balanced Assessment Materials from Mathematics Assessment Project*

<http://www.map.mathshell.org/materials/download.php?fileid=812>

### **ESSENTIAL QUESTIONS:**

- How do you understand and apply the Pythagorean Theorem to solve problems?

### **TASK COMMENTS:**

Tasks and lessons from the Mathematics Assessment Project are specifically designed to help teachers effectively formatively assess their students. The way the tasks and lessons are designed gives the teacher a clear understanding of what the students are able to do and not do. Within the lesson, teachers will find suggestions and question prompts that will help guide students towards understanding. For more information access the MAP website:

<http://www.map.mathshell.org/materials/background.php?subpage=summative>

The task, *Pythagorean Triples*, is a Mathematics Assessment Project Assessment Task that can be found at the

website: <http://www.map.mathshell.org/materials/tasks.php?taskid=280&subpage=expert>

The PDF version of the task can be found at the link below:

<http://www.map.mathshell.org/materials/download.php?fileid=812>

The scoring rubric can be found at the following link:

<http://www.map.mathshell.org/materials/download.php?fileid=813>

### **STANDARDS ADDRESSED IN THIS TASK:**

#### **Define trigonometric ratios and solve problems involving right triangles.**

**MGSE9-12.G.SRT.6** Understand that by similarity, side ratios in right triangles are properties of the angles in the triangle, leading to definitions of trigonometric ratios for acute angles.

**MGSE9-12.G.SRT.7** Explain and use the relationship between the sine and cosine of complementary angles.

**MGSE9-12.G.SRT.8** Use trigonometric ratios and the Pythagorean Theorem to solve right triangles in applied problems.

#### **Standards for Mathematical Practice**

This task uses all of the practices with emphasis on:

**2. Reason abstractly and quantitatively** by requiring students to make sense of quantities and their relationships to one another in problem situations.

**3. Construct viable arguments and critique the reasoning of others** by engaging students on discussion of why they agree or disagree with responses, decide whether they make sense, and ask useful questions to clarify or improve the arguments.

**6. Attend to precision** by requiring students to calculate efficiently and accurately; and to communicate precisely with others by using clear mathematical language to discuss their reasoning.

**7. Look for and make use of structure** by expecting students to apply rules, look for patterns and analyze structure

## Eratosthenes Finds the Circumference of the Earth Learning Task

### Standards Addressed in this Task

**MGSE9-12.G.SRT.6** Understand that by similarity, side ratios in right triangles are properties of the angles in the triangle, leading to definitions of trigonometric ratios for acute angles.

### Standards for Mathematical Practice

**2. Reason abstractly and quantitatively** by requiring students to make sense of quantities and their relationships to one another in problem situations.

**6. Attend to precision** by requiring students to calculate efficiently and accurately; and to communicate precisely with others by using clear mathematical language to discuss their reasoning.

**7. Look for and make use of structure** by expecting students to apply rules, look for patterns and analyze structure.

**8. Look for and express regularity in repeated reasoning** by expecting students to understand broader applications and look for structure and general methods in similar situations.

### **Student Misconceptions**

1. Some students believe that right triangles must be oriented a particular way.
2. Some students do not realize that opposite and adjacent sides need to be identified with reference to a particular acute angle in a right triangle.
3. Some students believe that the trigonometric ratios defined in this cluster apply to all triangles, but they are only defined for acute angles in right triangles

As Carl Sagan says in the television series *Cosmos*: Two complex ideas, the wheel and the globe, are grooved into our minds from infancy. It was only 5500 years ago that we finally saw how a rotating wheel could produce forward motion. Recognizing that Earth's apparently flat surface bends into the shape of a sphere was even more recent. Some cultures imagined Earth as a disc, some, box-shaped. The Egyptians said it was an egg, guarded at night by the moon. Only 2500 years ago, the Greeks finally decided Earth was a sphere. Plato argued that, since the sphere is a perfect shape, Earth must be spherical. Aristotle used observation. He pointed to the circular shadow Earth casts on the moon during an eclipse.

The Greeks had no way of knowing how large the globe might be. The most daring travelers saw Earth reaching farther still beyond the fringe of their journeys. Then, in 200 BC, travelers told the head of the Alexandria Library, Eratosthenes, about a well near present-day Aswan. The bottom of the well was lit by the sun at noon during the summer solstice. At that moment the sun was straight overhead. Eratosthenes realized he could measure the shadow cast by a tower in Alexandria while no shadow was being cast in Aswan. Then, knowing the distance to Aswan, calculating the Earth's radius would be simple.



In this task, you will examine the mathematics that Eratosthenes used to make his calculations and explore further the mathematics developed from the relationships he used.

### COMMENTS

*This standard requires that students have a deep understanding of the equalities among length ratios in similar triangles. This task is designed to arouse student interest by guiding them to understand how these ideas were used by Eratosthenes in 200 BC as he made the first calculation of the radius and circumference of the Earth.*

*Carl Sagan (Nov. 9, 1934 – Dec. 20, 1996) was an American astrophysicist who became famous for popularizing science. He co-wrote and presented the 1980 television series Cosmos: A Personal Voyage. A brief excerpt from the 13-part series is available at <http://dotsub.com/view/629a9966-dbef-4e05-85ed-1f4398833574>. (This URL is blocked by some school computer networks, but information technology support personnel should be able to make copies available for school use.) This video shows Carl Sagan (students may need to investigate who he was) discussing Eratosthenes and his clever calculations of the radius of the Earth. The video was shot on location, so students will see the actual tower and well that are illustrated in the diagram. The video is 6 ½ minutes long but is well worth the time to give a good opening for the task as well as hopefully generating a beginning discussion. The beginning discussion needs to review the basic facts about the summer solstice, which occurs on approximately June 21 each year. Students may need to look at a globe and orient themselves to the relative positions of Alexandria and Aswan.*

### Supplies needed

*Video of Cosmos*

*Map of Egypt showing Alexandria and Aswan*

*Globe of Earth (optional)*

*Time Needed: 100 minutes*

*Due to the complexity of the readability of this task, teachers may choose to assign this for acceleration or choose to use this as a whole group activity.*

*As shown in the solution, there are several important ideas to discuss in understanding why and how these triangles are similar. It is very important the students accept that the triangles, as indicated by Eratosthenes, are similar. Otherwise, this task will not help them build a conceptual basis for understanding the trigonometric ratios.*

*This diagram may mark the first time that students have encountered the Greek letter  $\theta$  (theta). If so, teachers may need to take a few minutes to talk about the Greek alphabet, and point out that, in higher mathematics,  $\theta$  is a standard variable used to represent an unknown angle measure. (A great site for the whole alphabet, with Flash media clips of how to write the letters, can be found at <http://aool.org/Greek/greekalphabet.html>. It includes upper and lower case letters with their English names).*

*This is a good opportunity to point out that  $\theta$  is located on their TI calculators. The variable key is labeled “X,T, $\theta$ ,n” to indicate that the calculator uses different variables in the different modes of Func (function), Par (parametric), Pol (polar), and Seq (sequence), respectively. Polar coordinates use an angle and a radius;  $\theta$  is variable used to represent the angle measure in this system.*

1. Looking at the diagram below, **verify that** the two triangles are similar: the one formed by the sun’s rays, the tower, and its shadow, and the one formed by the sun’s rays, the radius of the earth, and the distance to Aswan (ignore the curvature of the Earth as Eratosthenes did) Explain your reasoning.

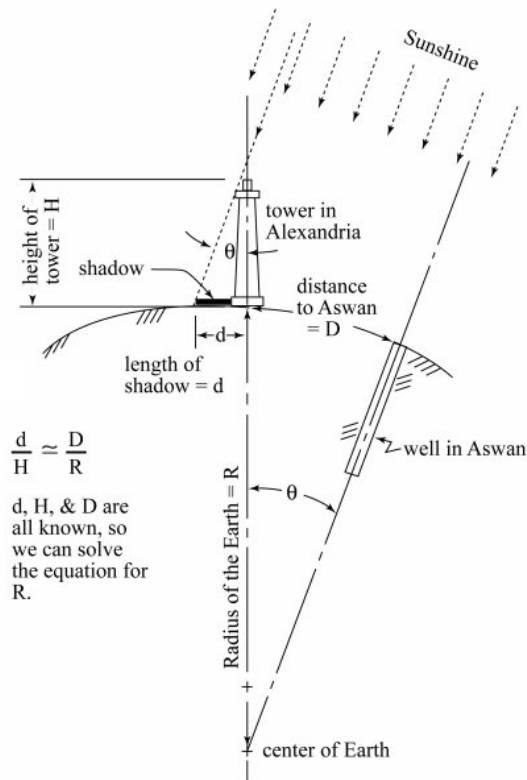

The above diagram is reproduced from the transcript and accompanying diagram for episode 1457 of the radio program The Engines of Our Ingenuity at <http://www.uh.edu/engines/epi1457.htm>. The Engines of Our Ingenuity is Copyright © 1988-1999 by John H., Lienhard.

**Solution(s):**

*When there is a way to correspond the angles of two triangles so that corresponding angles are congruent, then the two triangles are similar by AAA (angle-angle-angle). We now explain such a correspondence for these two triangles.*

*The lines representing the sun’s rays intersect the line representing the radius of the Earth. Since the sun’s rays are parallel as they strike the Earth, alternate interior angles formed by the intersection of the sun’s rays with the Earth radius are congruent. Thus, the two angles marked with measure  $\theta$  are indeed congruent.*

*It is a standard practice to represent a vertical object on the Earth’s surface as perpendicular to a line representing the ground. As shown in the figure, this practice ignores the curvature*



of the Earth. Eratosthenes also ignored the curvature of the Earth over the distance from the tower base to the end of its shadow and over the distance from Alexandria (the location of the tower) to Aswan (the location of the well). Assuming a flat Earth (over these short distances compared to the size of the Earth) gives right angles where the base of the tower meets the Earth and where the straight line from the base of the tower meets the sun's ray entering the well. Any two right angles are congruent.

When we have two angles in triangles congruent, the third angles must be congruent because the sum of the measures of an angle in a triangle is  $180^\circ$ . Thus, the third angles are congruent, and, hence, the triangles are similar by AAA.

2. Focus on the two similar triangles from the diagram in *Item 1*.
  - a. Write a proportion that shows the relationship of the small triangle to the large triangle.

Comment(s):

In previous years, students studied similar figures extensively. The concept of one constant of proportionality for all linear measures in the figures was emphasized in this study. Hence, students are first asked to think in terms of the scaling factor in going from one triangle to the other. The solution shows the ratio of lengths in the larger triangle to lengths in the smaller one. Of course, the reciprocal relationships also constitute a correct answer.

Solution(s):

The ratio of lengths in the larger triangle to lengths in the smaller triangle:  $\frac{R}{H} = \frac{D}{d}$ .

Rearrange the similarity statement in *part a* to match the statement in the given diagram in *Item 1*. Explain why this proportion is a true proportion.

Solution(s):

The proportion statement in the diagram is written as  $d = \frac{D}{H} R$ . We need to switch places with the  $R$  and  $d$  from the above proportion to obtain this proportion. This proportion is a true proportion because, starting with  $\frac{R}{H} = \frac{D}{d}$ , we can multiply both sides of the equation by the product  $dH$  (which is nonzero because both  $d$  and  $H$  are nonzero lengths) to obtain the equation  $dR = DH$ . Now, we divide both sides of this equation by the product  $HR$  (which is nonzero because both  $H$  and  $R$  are nonzero lengths) to obtain  $\frac{dR}{HR} = \frac{DH}{HR}$ . This simplifies to give that  $\frac{d}{H} = \frac{D}{R}$ , as desired.

3. Now, look at the triangles isolated from the diagram as shown at the right.

- a. Knowing that these triangles represent the original diagram, where should the right angles be located?

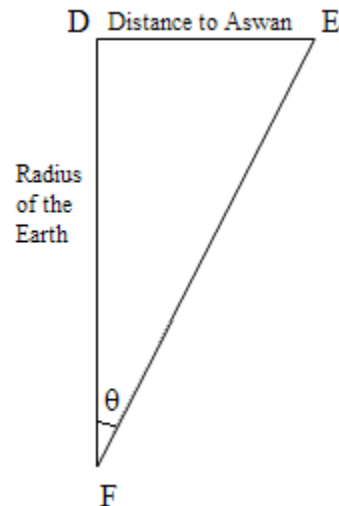
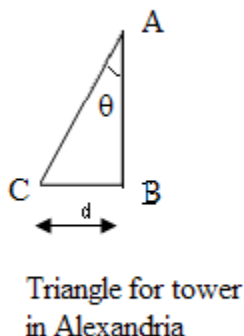

**Solution(s):**

*The right angles should be located at vertices B and D, respectively.*

- b. Using the right angles that you have identified, identify the legs and hypotenuse of each right triangle.

**Solution(s):**

*Smaller triangle:                      Larger triangle:  
 legs: AB, BC    legs: DE, DF  
 hypotenuse: AC    hypotenuse: EF*

- c. Rewrite your proportion from above using the segments from triangle ABC and triangle DEF.

**Solution(s):**

$$\frac{\overline{BC}}{\overline{AB}} = \frac{\overline{DE}}{\overline{DF}}, \text{ where } \overline{BC} \text{ is the length of side BC and so forth.}$$

- d. By looking at the triangle ABC, describe how the sides AB and BC are related to angle  $\theta$ .

**Solution(s):**

*Side AB lies on one of the rays forming angle  $\theta$ ; side BC is opposite angle  $\theta$ .*

- e. By looking at the triangle DEF, describe how the sides DE and DF are related to angle  $\theta$ .

**Solution(s):**

*Side DF lies on one of the rays forming angle  $\theta$ ; side DE is opposite angle  $\theta$ .*

4. If we rearrange the triangles so that the right angles and corresponding line segments align as shown in the figure below, let's look again at the proportions and how they relate to the angles of the triangles.

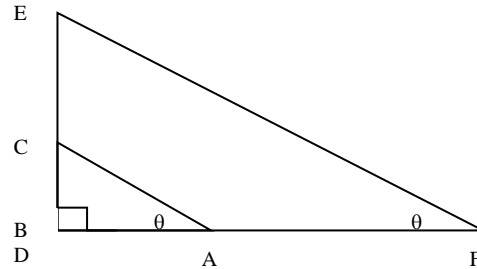

Looking at the proportion you wrote in 3c,  $\frac{\overline{BC}}{\overline{AB}} = \frac{\overline{DE}}{\overline{DF}}$  and the answers to 3d and 3e, when would a proportion like this always be true? Is it dependent upon the length of the sides or the angle measure? Do the triangles always have to be similar right triangles? Why or why not?

**Solution(s):**

*Students should recognize at this point that the triangles need to be similar to assure that the angles are congruent and the sides are proportional. Thus leading to the recognition that similar right triangles will have the ratios, getting them ready to define the trigonometric ratios and having an understanding of why you would want to have these ratios (and functions) since for a given angle, the ratios are the same no matter what length the side.*

## Eratosthenes Finds the Circumference of the Earth Learning Task

### Standards Addressed in this Task

**MGSE9-12.G.SRT.6** Understand that by similarity, side ratios in right triangles are properties of the angles in the triangle, leading to definitions of trigonometric ratios for acute angles.

### Standards for Mathematical Practice

**2. Reason abstractly and quantitatively** by requiring students to make sense of quantities and their relationships to one another in problem situations.

**6. Attend to precision** by requiring students to calculate efficiently and accurately; and to communicate precisely with others by using clear mathematical language to discuss their reasoning.

**7. Look for and make use of structure** by expecting students to apply rules, look for patterns and analyze structure.

**8. Look for and express regularity in repeated reasoning** by expecting students to understand broader applications and look for structure and general methods in similar situations.

As Carl Sagan says in the television series *Cosmos*: Two complex ideas, the wheel and the globe, are grooved into our minds from infancy. It was only 5500 years ago that we finally saw how a rotating wheel could produce forward motion. Recognizing that Earth's apparently flat surface bends into the shape of a sphere was even more recent. Some cultures imagined Earth as a disc, some, box-shaped. The Egyptians said it was an egg, guarded at night by the moon. Only 2500 years ago, the Greeks finally decided Earth was a sphere. Plato argued that, since the sphere is a perfect shape, Earth must be spherical. Aristotle used observation. He pointed to the circular shadow Earth casts on the moon during an eclipse.

The Greeks had no way of knowing how large the globe might be. The most daring travelers saw Earth reaching farther still beyond the fringe of their journeys. Then, in 200 BC, travelers told the head of the Alexandria Library, Eratosthenes, about a well near present-day Aswan. The bottom of the well was lit by the sun at noon during the summer solstice. At that moment the sun was straight overhead. Eratosthenes realized he could measure the shadow cast by a tower in Alexandria while no shadow was being cast in Aswan. Then, knowing the distance to Aswan, calculating the Earth's radius would be simple.

In this task, you will examine the mathematics that Eratosthenes used to make his calculations and explore further the mathematics developed from the relationships he used.

1. Looking at the diagram below, **verify that** the two triangles are similar: the one formed by the sun's rays, the tower, and its shadow, and the one formed by the sun's rays, the radius of the earth, and the distance to Aswan (ignore the curvature of the Earth as Eratosthenes did). Explain your reasoning.

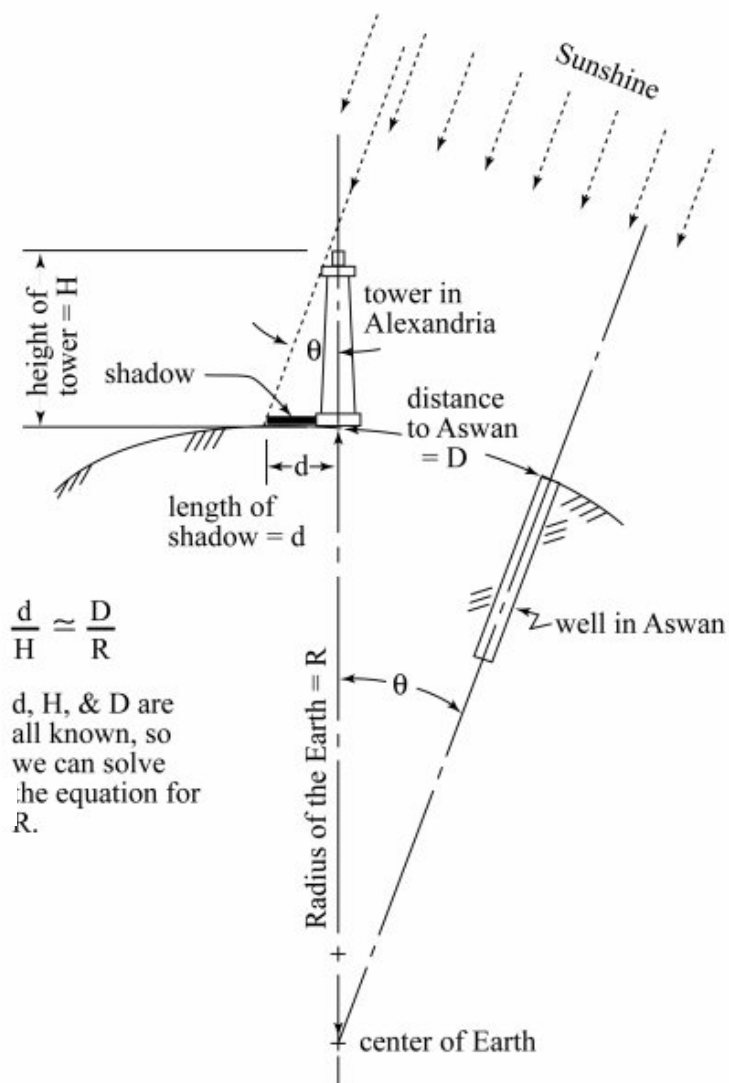

The above diagram is reproduced from the transcript and accompanying diagram for episode 1457 of the radio program *The Engines of Our Ingenuity* at <http://www.uh.edu/engines/epi1457.htm>.

*The Engines of Our Ingenuity* is Copyright © 1988-1999 by John H., Lienhard.

2. Focus on the two similar triangles from the diagram in *Item 1*.
  - a. Write a proportion that shows the relationship of the small triangle to the large triangle.
  - b. Rearrange the similarity statement in *part a* to match the statement in the given diagram in *Item 1*. Explain why this proportion is a true proportion.

3. Now, look at the triangles isolated from the diagram as shown at the right.

a. Knowing that these triangles represent the original diagram, where should the right angles be located?

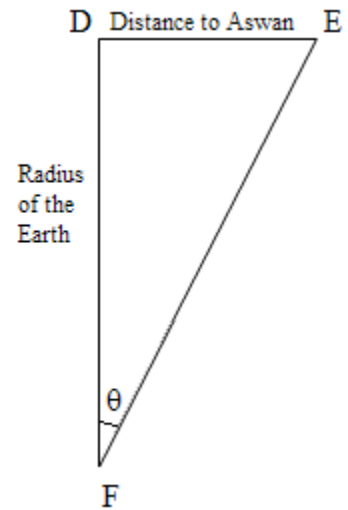
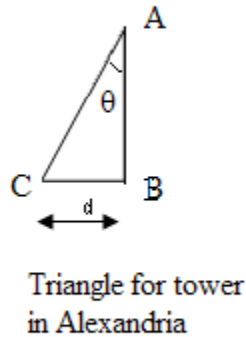

b. Using the right angles that you have identified, identify the legs and hypotenuse of each right triangle.

c. Rewrite your proportion from above using the segments from triangle ABC and triangle DEF.

d. By looking at the triangle ABC, describe how the sides AB and BC are related to angle  $\theta$ .

e. By looking at the triangle DEF, describe how the sides DE and DF are related to angle  $\theta$ .

**Georgia Department of Education**  
Georgia Standards of Excellence Framework  
*GSE Geometry • Unit 3*

If we rearrange the triangles so that the right angles and corresponding line segments align as shown in the figure below, let's look again at the proportions and how they relate to the angles of the triangles.

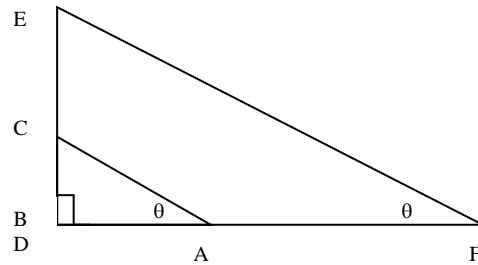

Looking at the proportion you wrote in 3c,  $\frac{\overline{BC}}{\overline{AB}} = \frac{\overline{DE}}{\overline{DF}}$  and the answers to 3d and 3e, when would a proportion like this always be true? Is it dependent upon the length of the sides or the angle measure? Do the triangles always have to be similar right triangles? Why or why not?

## Discovering Special Triangles Learning Task

*Special Right Triangles are not specified in the standards, but do provide a method in which to address MGSE9-12.G.SRT.6.*

### Standards Addressed in this Unit

**MGSE9-12.G.SRT.6** Understand that by similarity, side ratios in right triangles are properties of the angles in the triangle, leading to definitions of trigonometric ratios for acute angles.

### Standards for Mathematical Practice

**2. Reason abstractly and quantitatively** by requiring students to make sense of quantities and their relationships to one another in problem situations.

**6. Attend to precision** by requiring students to calculate efficiently and accurately; and to communicate precisely with others by using clear mathematical language to discuss their reasoning.

**7. Look for and make use of structure** by expecting students to apply rules, look for patterns and analyze structure.

**8. Look for and express regularity in repeated reasoning** by expecting students to understand broader applications and look for structure and general methods in similar situations.

### Student Misconceptions

1. Some students believe that right triangles must be oriented a particular way.
2. Some students do not realize that opposite and adjacent sides need to be identified with reference to a particular acute angle in a right triangle.
3. Some students believe that the trigonometric ratios defined in this cluster apply to all triangles, but they are only defined for acute angles in right triangles.

### Part 1

1. Adam, a construction manager in a nearby town, needs to check the uniformity of Yield signs around the state and is checking the heights (altitudes) of the Yield signs in your locale. Adam knows that all yield signs have the shape of an equilateral triangle. Why is it sufficient for him to check just the heights (altitudes) of the signs to verify uniformity?

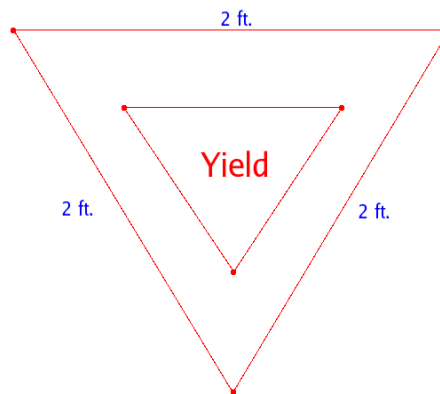



Solution(s):

*All equilateral triangles are similar. To be uniform, they need to be congruent. Since they are similar, they only need one measurement, such as the height, to guarantee that they are the same size.*

2. A Yield sign from a street near your home is pictured to the right. It has the shape of an equilateral triangle with a side length of 2 feet. If the altitude of the triangular sign is drawn, you split the Yield sign in half vertically, creating two  $30^\circ$ - $60^\circ$ - $90^\circ$  right triangles, as shown to the right. For now, we'll focus on the right triangle on the right side. (We could just as easily focus on the right triangle on the left; we just need to pick one.) We know that the hypotenuse is 2 ft., that information is given to us. The shorter leg has length 1 ft. **Why?**

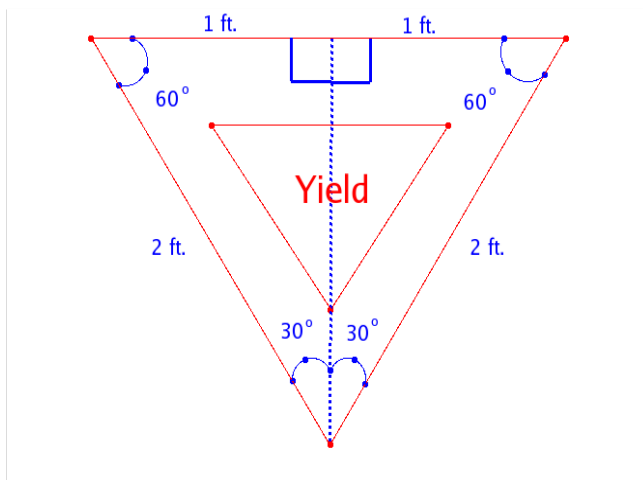

**Verify** that the length of the third side, the altitude, is  $\sqrt{3}$  ft.

Comment(s):

*Students have developed triangle congruence theorems for right triangles.. Specifically, they established that, if two right triangles have one of the following pairs or congruent parts, then the triangles are congruent: the hypotenuse and a leg (HL), two legs (LL), the hypotenuse and an acute angle (HA), a leg and an acute angle (LA).*

Solution(s):

*Shorter leg has length 1 ft.:*

*Drawing the altitude creates two right triangles whose hypotenuses both have length 2 ft. and whose longer leg is the altitude. So, the two right triangles are congruent by the Hypotenuse-Leg Theorem (HL). Then, the altitude splits one 2 ft. side into two congruent segments, so each must have length 1 ft.*

*Altitude as length  $\sqrt{3}$  ft.:*

*Let  $x$  represent the length of the altitude. By the Pythagorean Theorem,  $x^2 + 1^2 = 2^2$ .*

*Then,  $x^2 + 1 = 4 \rightarrow x^2 = 3 \rightarrow x = \sqrt{3}$  since  $x > 0$ .*

3. The construction manager, Adam, also needs to know the altitude of the smaller triangle within the sign. Each side of this smaller equilateral triangle is 1 ft. long. **Explain why** the altitude of this equilateral triangle is  $\frac{\sqrt{3}}{2}$ .

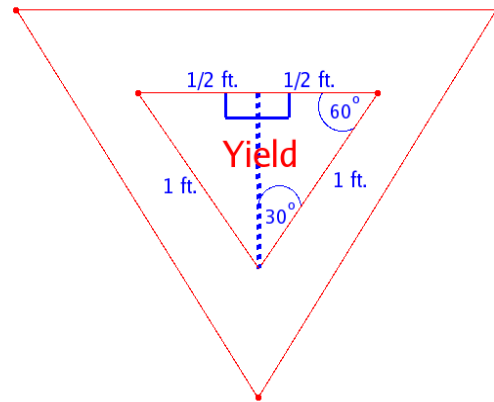

Comment(s):

*Some students may explain by applying the same reasoning used with the larger triangle. Using similarity of the triangles provides a simpler explanation. If students do not notice similarity here, they may realize that the triangles are similar as they complete the chart in Item 4. The critically important concept is one developed in Item 4 below: Students should comprehend that all 30°-60°-90° right triangles have this pattern of lengths for the hypotenuse, shorter leg, and longer leg:  $2a, a, a\sqrt{3}$ .*

Solution(s):

*The smaller triangle is similar to the first since equilateral triangles are also equiangular. Since each side of the smaller triangle has length 1 ft, which is half the length of a side of the larger triangle, the altitude of the smaller triangle will have length  $\frac{1}{2}\sqrt{3} = \frac{\sqrt{3}}{2}$*

4. Now that we have found the altitudes of both equilateral triangles, we look for patterns in the data. Fill in the first two rows of the chart below, and write down any observations you make. Then fill in the third and fourth rows.

Solution(s):

*After completing the first two rows, we see that the shorter leg has length half the length of the hypotenuse and the longer leg has a length that is  $\sqrt{3}$  times the length of the shorter leg.*

Side Length of Equilateral Triangle	Each 30°-60°-90° right triangle formed by drawing altitude		
	Hypotenuse Length	Shorter Leg Length	Longer Leg Length
2	2	1	$\sqrt{3}$
1	1	$\frac{1}{2}$	$\frac{\sqrt{3}}{2}$
4	4	2	$2\sqrt{3}$
6	6	3	$3\sqrt{3}$

5. What is true about the lengths of the sides of any 30°-60°-90° right triangle? How do you know?

Comment(s):

*By the time they have completed the table, students should notice that, for a given hypotenuse length  $2a$ , the length of the shorter leg will be  $a$  and the length of the longer leg will be  $a\sqrt{3}$ . They should comprehend this as a pattern found with similar shapes and, if they have not do so already, explicitly refer to the similarity of all 30°-60°-90° right triangles.*

Solution(s):

*All 30°-60°-90° right triangles are similar because all their angles are congruent. If the hypotenuse of a 30°-60°-90° right triangle has length  $2a$ , then, the hypotenuse is  $\underline{a}$  times as long as the hypotenuse of the 30°-60°-90° right triangle whose hypotenuse has length 2. Then all of the sides are  $\underline{a}$  times as long as the sides of the 30°-60°-90° right triangle whose hypotenuse has length 2. Hence, for any 30°-60°-90° right triangle, the lengths of the hypotenuse, shorter leg, and longer leg follow the pattern:  $2a$ ,  $a$ ,  $a\sqrt{3}$ , respectively.*

6. Use your answer for *Item 5* as you complete the table below. Do not use a calculator; leave answers exact.

Comment(s):

*Completing this table accomplishes two goals: (1) students truly understand the relationships among the lengths of the sides in a 30°-60°-90° right triangle and (2) students maintain basic computational skills with fractions and radicals. As shown in the solution table below, for  $\Delta\#7$ , students are not expected to rationalize the denominator.*

*However, students are expected to use the product property of square roots:  
 $\sqrt{a} \cdot \sqrt{b} = \sqrt{ab}$  for all nonnegative real numbers  $a$  and  $b$ .*

*Solution(s):*

*Solution(s):*

<b>In a 30°-60°-90° right triangle</b>	Δ #1	Δ #2	Δ #3	Δ #4	Δ #5	Δ #6	Δ #7	Δ #8
hypotenuse length	11	$2\pi$	$\frac{2}{7}$	$\frac{24}{5}$	$3\sqrt{5}$	$2\sqrt{3}$	$\frac{8}{\sqrt{3}}$	$\sqrt{2}$
shorter leg length	$\frac{11}{2}$	$\pi$	$\frac{1}{7}$	$\frac{12}{5}$	$\frac{3}{2}\sqrt{5}$	$\sqrt{3}$	$\frac{4}{\sqrt{3}}$	$\frac{\sqrt{2}}{2}$
longer leg length	$\frac{11}{2}\sqrt{3}$	$\pi\sqrt{3}$	$\frac{\sqrt{3}}{7}$	$\frac{12}{5}\sqrt{3}$	$\frac{3}{2}\sqrt{15}$	3	4	$\frac{\sqrt{6}}{2}$

**Part 2**

A baseball diamond is, geometrically speaking, a square turned sideways. Each side of the diamond measures 90 feet. (See the diagram to the right.) A player is trying to slide into home base, but the ball is all the way at second base. Assuming that the second baseman and catcher are standing in the center of second base and home, respectively, we can calculate how far the second baseman has to throw the ball to get it to the catcher.

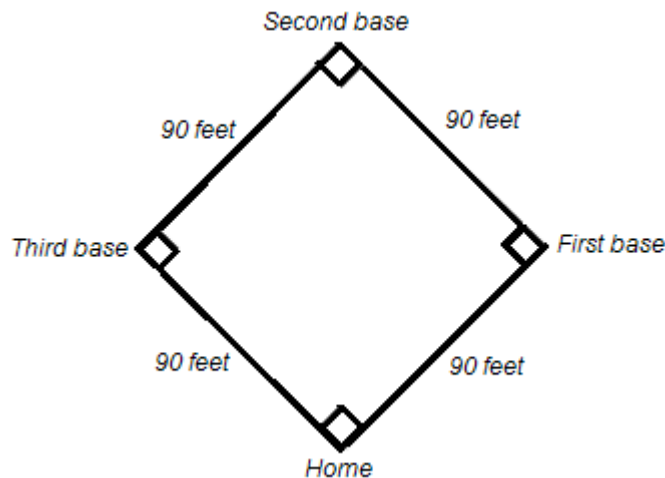

7. If we were to split the diamond in half vertically, we would have two  $45^\circ$ - $45^\circ$ - $90^\circ$  right triangles. (The line we would use to split the diamond would bisect the  $90^\circ$  angles at home and second base, making two angles equal to  $45^\circ$ , as shown in the baseball diamond to the right below.) Let us examine one of these  $45^\circ$ - $45^\circ$ - $90^\circ$  right triangles. You know that the two legs are 90 feet each. Using the Pythagorean Theorem, **verify** that the hypotenuse, or the displacement of the ball, is  $90\sqrt{2}$  feet (approximately 127.3 feet) long.

*Solution(s):*

*Each of the legs has length 90 ft. Let  $h$  denote the length of the hypotenuse in feet.*

*Then,*

$$h^2 = (90)^2 + (90)^2$$

$$h^2 = 2 \cdot (90)^2$$

$$h = \sqrt{2 \cdot (90)^2}$$

$$= 90\sqrt{2}$$

$$\approx 127.3$$

*Thus, the displacement of the ball is exactly  $90\sqrt{2}$  feet, or approximately 127.3 feet.*

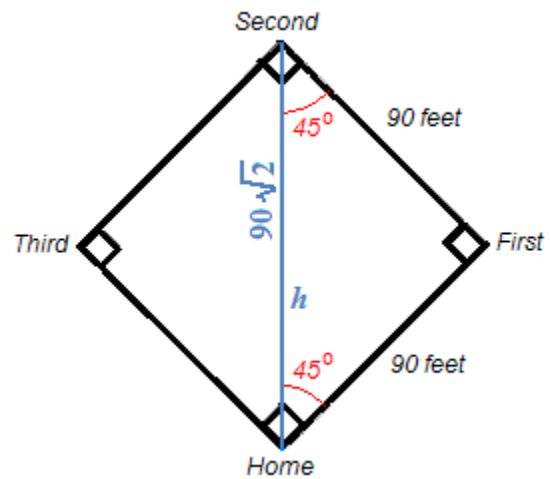

8. Without moving from his position, the catcher reaches out and tags the runner out before he gets to home base. The catcher then throws the ball back to a satisfied pitcher, who at the time happens to be standing at the exact center of the baseball diamond. We can calculate the displacement of the ball for this throw also. Since the pitcher is standing at the center of the field and the catcher is still at home base, the throw will cover half of the distance we just found in *Item 7*. Therefore, the distance for this second throw is  $45\sqrt{2}$  feet, half of  $90\sqrt{2}$ , or approximately 63.6 feet. If we were to complete the triangle between home base, the center of the field, and first base, we would have side lengths of  $45\sqrt{2}$  feet,  $45\sqrt{2}$  feet, and 90 feet.

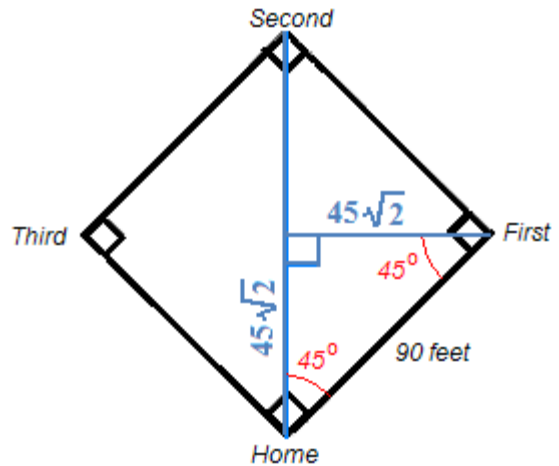

- a. Now that we have found the side lengths of two 45°- 45°- 90° triangles, we can observe a pattern in the lengths of sides of all 45°- 45°- 90° right triangles. Using the exact values written using square root expressions, fill in the first two rows of the table at the right.

**In each 45°- 45°- 90° right triangle**

Leg Length	Other Leg Length	Hypotenuse Length
90 ft.	90 ft.	$90\sqrt{2}$ ft.
$45\sqrt{2}$ ft.	$45\sqrt{2}$ ft.	90 ft.

- b. Show, by direct calculation, that the entries in the second row are related in the same way as the entries in the second row.

Comment(s):

*In the first row, the pattern is clearly that the two legs have the same length and the length of the hypotenuse is  $\sqrt{2}$  times the length of a leg. In the second row, we see that the legs have the same length, but it is not obvious that the length of the hypotenuse is  $\sqrt{2}$  times the length of a leg. Students are asked to perform the calculation to convince themselves that the pattern holds.*

Solution(s):

*Without calculation, we see that the legs of the triangle in row 2 have the same length.*

*Multiplying this leg length by  $\sqrt{2}$  yields the desired confirmation:*

$$(45\sqrt{2})(\sqrt{2}) = 45(\sqrt{2})^2 = 45(2) = 90.$$

9. What is true about the lengths of the sides of any 45°- 45°- 90° right triangle? How do you know?

Solution(s):

*All 45°- 45°- 90° right triangles are similar because all their angles are congruent. In the two such triangles above, the legs have the same length and the length of the hypotenuse is  $\sqrt{2}$  times the length of a leg. The ratio of one side to another in one triangle is the same as the ratio of corresponding sides in a similar triangle. Hence, in any 45°- 45°- 90° triangle, the two legs have the same length and the length of the hypotenuse is  $\sqrt{2}$  times the length of a leg.*

**Georgia Department of Education**  
 Georgia Standards of Excellence Framework  
 GSE Geometry • Unit 3

10. Use your answer for *Item 9* as you complete the table below. Do not use a calculator; leave answers exact.

Comment(s):

*As shown in the solution table below, students are not expected to rationalize denominators. However, students are expected to use the product property of square roots:  $\sqrt{a} \cdot \sqrt{b} = \sqrt{ab}$ , for all nonnegative real numbers  $a$  and  $b$ .*

Solution(s):

<b>45°-45°-90° triangle</b>	$\Delta^{\perp}\#1$	$\Delta^{\perp}\#2$	$\Delta^{\perp}\#3$	$\Delta^{\perp}\#4$	$\Delta^{\perp}\#5$	$\Delta^{\perp}\#6$	$\Delta^{\perp}\#7$	$\Delta^{\perp}\#8$
hypotenuse length	$4\sqrt{2}$	$\pi\sqrt{2}$	11	1	$\frac{\sqrt{6}}{7}$	$\sqrt{6}$	$3\sqrt{5}$	$\frac{12\sqrt{2}}{5}$
one leg length	4	$\pi$	$\frac{11}{\sqrt{2}}$	$\frac{\sqrt{2}}{2}$	$\frac{\sqrt{3}}{7}$	$\sqrt{3}$	$\frac{3\sqrt{5}}{\sqrt{2}}$	$\frac{12}{5}$
other leg length	4	$\pi$	$\frac{11}{\sqrt{2}}$	$\frac{\sqrt{2}}{2}$	$\frac{\sqrt{3}}{7}$	$\sqrt{3}$	$\frac{3\sqrt{5}}{\sqrt{2}}$	$\frac{12}{5}$

## Discovering Special Triangles Learning Task

### Standards Addressed in this Unit

**MGSE9-12.G.SRT.6** Understand that by similarity, side ratios in right triangles are properties of the angles in the triangle, leading to definitions of trigonometric ratios for acute angles.

### Standards for Mathematical Practice

**2. Reason abstractly and quantitatively** by requiring students to make sense of quantities and their relationships to one another in problem situations.

**6. Attend to precision** by requiring students to calculate efficiently and accurately; and to communicate precisely with others by using clear mathematical language to discuss their reasoning.

**7. Look for and make use of structure** by expecting students to apply rules, look for patterns and analyze structure.

**8. Look for and express regularity in repeated reasoning** by expecting students to understand broader applications and look for structure and general methods in similar situations.

### Part 1

1. Adam, a construction manager in a nearby town, needs to check the uniformity of Yield signs around the state and is checking the heights (altitudes) of the Yield signs in your locale. Adam knows that all yield signs have the shape of an equilateral triangle. Why is it sufficient for him to check just the heights (altitudes) of the signs to verify uniformity?

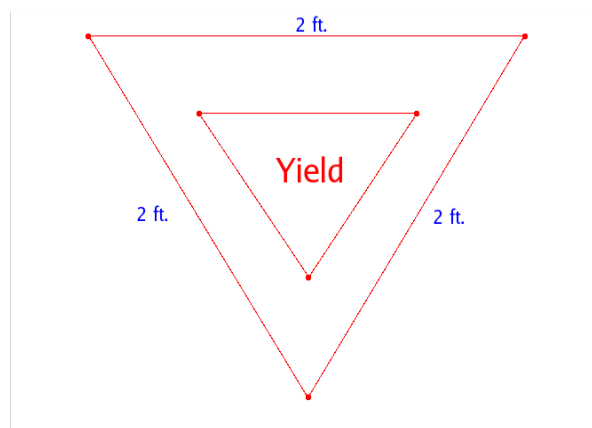



2. A Yield sign from a street near your home is pictured to the right. It has the shape of an equilateral triangle with a side length of 2 feet. If the altitude of the triangular sign is drawn, you split the Yield sign in half vertically, creating two  $30^\circ$ - $60^\circ$ - $90^\circ$  right triangles, as shown to the right. For now, we'll focus on the right triangle on the right side. (We could just as easily focus on the right triangle on the left; we just need to pick one.) We know that the hypotenuse is 2 ft., that information is given to us. The shorter leg has length 1 ft. **Why?**

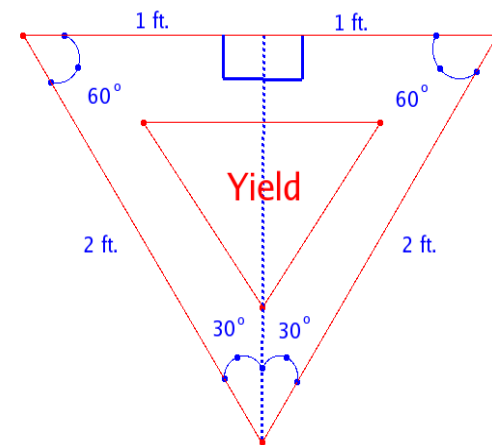

**Verify** that the length of the third side, the altitude, is  $\sqrt{3}$  ft.

3. The construction manager, Adam, also needs to know the altitude of the smaller triangle within the sign. Each side of this smaller equilateral triangle is 1 ft. long. **Explain why** the altitude of this equilateral triangle is  $\frac{\sqrt{3}}{2}$ .

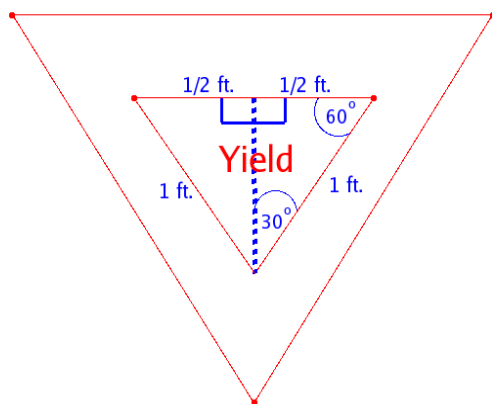

4. Now that we have found the altitudes of both equilateral triangles, we look for patterns in the data. Fill in the first two rows of the chart below, and write down any observations you make. Then fill in the third and fourth rows.

Side Length of Equilateral Triangle	Each $30^\circ$ - $60^\circ$ - $90^\circ$ right triangle formed by drawing altitude		
	Hypotenuse Length	Shorter Leg Length	Longer Leg Length
2			
1			
4			
6			

5. What is true about the lengths of the sides of any  $30^\circ$ - $60^\circ$ - $90^\circ$  right triangle? How do you know?

6. Use your answer for *Item 5* as you complete the table below. Do not use a calculator; leave answers exact.

<b>30°-60°-90° triangle</b>	$\Delta \square \#1$	$\Delta \square \#2$	$\Delta \square \#3$	$\Delta \square \#4$	$\Delta \square \#5$	$\Delta \square \#6$	$\Delta \square \#7$	$\Delta \square \#8$
hypotenuse length	11				$3\sqrt{5}$			
shorter leg length		$\pi$		$\frac{12}{5}$		$\sqrt{3}$		$\frac{\sqrt{2}}{2}$
longer leg length			$\frac{\sqrt{3}}{7}$				4	

### Part 2

A baseball diamond is, geometrically speaking, a square turned sideways. Each side of the diamond measures 90 feet. (See the diagram to the right.) A player is trying to slide into home base, but the ball is all the way at second base. Assuming that the second baseman and catcher are standing in the center of second base and home, respectively, we can calculate how far the second baseman has to throw the ball to get it to the catcher.

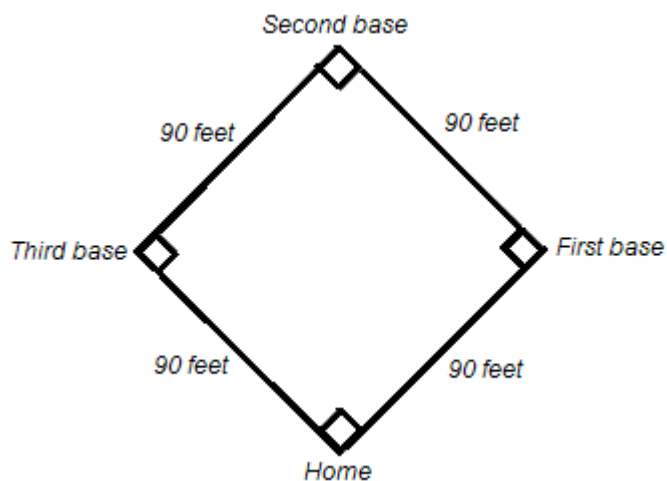

7. If we were to split the diamond in half vertically, we would have two 45°- 45°- 90° right triangles. (The line we would use to split the diamond would bisect the 90° angles at home and second base, making two angles equal to 45°, as shown in the baseball diamond to the right below.) Let us examine one of these 45°- 45°- 90° right triangles. You know that the two legs are 90 feet each. Using the Pythagorean Theorem, **verify** that the hypotenuse, or the displacement of the ball, is  $90\sqrt{2}$  feet (approximately 127.3 feet) long.
8. Without moving from his position, the catcher reaches out and tags the runner out before he gets to home base. The catcher then throws the ball back to a satisfied pitcher, who at the time happens to be standing at the exact center of the baseball diamond. We can calculate the displacement of the ball for this throw also. Since the pitcher is standing at the center of the field and the catcher is still at home base, the throw will cover half of the distance we just found in *Item 7*. Therefore, the distance for this second throw is  $45\sqrt{2}$  feet, half of

$90\sqrt{2}$ , or approximately 63.6 feet. If we were to complete the triangle between home base, the center of the field, and first base, we would have side lengths of  $45\sqrt{2}$  feet,  $45\sqrt{2}$  feet, and 90 feet.

- a. Now that we have found the side lengths of two  $45^\circ$ - $45^\circ$ - $90^\circ$  triangles, we can observe a pattern in the lengths of sides of all  $45^\circ$ - $45^\circ$ - $90^\circ$  right triangles. Using the exact values written using square root expressions, fill in the first two rows of the table at the right.
- b. Show, by direct calculation, that the entries in the second row are related in same way as the entries in the second row.

<b>In each <math>45^\circ</math>-<math>45^\circ</math>-<math>90^\circ</math> right triangle</b>		
Leg Length	Other Leg Length	Hypotenuse Length
90 ft.		
$45\sqrt{2}$ ft.		

9. What is true about the lengths of the sides of any  $45^\circ$ - $45^\circ$ - $90^\circ$  right triangle? How do you know?
10. Use your answer for *Item 9* as you complete the table below. Do not use a calculator; leave answers exact.

<b><math>45^\circ</math>-<math>45^\circ</math>-<math>90^\circ</math> triangle</b>	△ □ #1	△ □ #2	△ □ #3	△ □ #4	△ □ #5	△ □ #6	△ □ #7	△ □ #8
hypotenuse length			11				$3\sqrt{5}$	
one leg length		$\pi$		$\frac{\sqrt{2}}{2}$		$\sqrt{3}$		$\frac{12}{5}$
other leg length	4				$\frac{\sqrt{3}}{7}$			

## Finding Right Triangles in Your Environment Learning Task

### Standards Addressed in this Unit

**MGSE9-12.G.SRT.6** Understand that by similarity, side ratios in right triangles are properties of the angles in the triangle, leading to definitions of trigonometric ratios for acute angles.

**MGSE9-12.G.SRT.7** Explain and use the relationship between the sine and cosine of complementary angles.

**MGSE9-12.G.SRT.8** Use trigonometric ratios and the Pythagorean Theorem to solve right triangles in applied problems.

### Standards for Mathematical Practice

- 1. Make sense of problems and persevere in solving them** by requiring students to interpret and make meaning of a problem and find a logical starting point, and to monitor their progress and change their approach to solving the problem, if necessary.
- 2. Reason abstractly and quantitatively** by requiring students to make sense of quantities and their relationships to one another in problem situations.
- 3. Construct viable arguments and critique the reasoning of others** by engaging students on discussion of why they agree or disagree with responses, decide whether they make sense, and ask useful questions to clarify or improve the arguments.
- 4. Model with mathematics** by expecting students to apply the mathematics concepts they know in order to solve problems arising in everyday situations, and reflect on whether the results are sensible for the given scenario.
- 5. Use appropriate tools strategically** by expecting students to consider available tools when solving a mathematical problem. These tools might include pencil and paper, concrete models, a ruler, a protractor, a compass, a calculator, software, etc.
- 6. Attend to precision** by requiring students to calculate efficiently and accurately; and to communicate precisely with others by using clear mathematical language to discuss their reasoning.
- 7. Look for and make use of structure** by expecting students to apply rules, look for patterns and analyze structure.
- 8. Look for and express regularity in repeated reasoning** by expecting students to understand broader applications and look for structure and general methods in similar situations.

### Supplies needed

- Heavy stock, smooth unlined paper for constructing triangles (unlined index cards, white or pastel colors are a good choice)
- Compass and straight edge for constructing triangles

- Protractor for verifying measures of angles
- Ruler in centimeters for measuring sides of constructed triangles

*Comments:*

*This task builds a conceptual foundation for solving application problems using the trigonometric ratios. This early introduction to the theoretical basis for solving right triangles prepares students for work later in the unit and provides motivation for the next task on the trigonometric ratios.*

*In this task, instead of using a value of a trigonometric function directly, students construct a triangle similar to the one described in the applied problem and measure side lengths of that triangle to find the value of the needed ratio. Students will need supplies to construct their triangles.*

1. Look around you in your room, your school, your neighborhood, or your city. Can you find right triangles in everyday objects? List at least ten right triangles that you find. Draw pictures of at least three of them, labeling the  $90^\circ$  angle that makes the triangle a right triangle.

*Comment(s):*

*Student lists will likely include many of the following:*

- (1) *Shelf bracket*
- (2) *Wedge-shaped door stop*
- (3) *Portion of a wall that has a level top showing above slanted ground*
- (4) *Area created by a diagonal side walk crossing sidewalks that meet at a right angle*
- (5) *Pole, guy wire, and level ground*
- (6) *Wall, ladder leaning against the wall, level floor*
- (7) *Rafter, ceiling joist, and brace (in the attic)*
- (8) *Half of seesaw, support for the seesaw, and ground (when one end of the seesaw is resting on the ground)*
- (9) *Side of pup tent, center pole, ground (when viewed from the end)*
- (10) *Any of the four sections of a kite created by the cross braces*

*Students should realize that putting an altitude in a triangle creates two right triangles. Many additional examples can come from application of this concept.*

*Pictures for (2), (8), and (10)*



Door stop



Seesaw

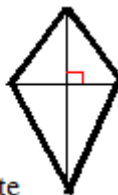

Kite

2. An older building in the school district sits on the side of a hill and is accessible from ground level on both the first and second floors. However, access at the second floor requires use of several stairs. Amanda and Tom have been given the task of designing a ramp so that people who cannot use stairs can get into the building on the second floor level. The rise has to be 5 feet, and the angle of the ramp has to be 15 degrees.

- a. Tom and Amanda need to determine how long that ramp should be. One way to do this is to use a compass and straightedge to construct a  $15^\circ$ - $75^\circ$ - $90^\circ$  triangle on your paper. Such a triangle must be similar to the triangle defining the ramp. **Explain why the triangles are similar.**



*The diagram is not to scale.*

*Solution(s):*

*Since the triangle for the ramp is a right triangle with an acute angle of  $15^\circ$ , the other acute angle is  $75^\circ$ . Thus, the triangle for the ramp is a  $15^\circ$ - $75^\circ$ - $90^\circ$  triangle.*

- b. Construct a  $15^\circ$ - $75^\circ$ - $90^\circ$  triangle on your paper using straightedge and compass. Use a protractor to verify the angle measurements. (Alternative: If dynamic geometry software is available, the construction and verification of angle measurements can be done using the software.) You'll use this triangle in *part c*.

*Comment(s):*

*A  $15^\circ$ - $75^\circ$ - $90^\circ$  triangle was chosen for this part of the task because such a triangle is constructible using a compass and straightedge, yet it is not one of the special triangles where ratios of side lengths are already known.*

*Other tools can be used in the construction, such as using a Mira for constructing the right angle in the triangle. If a variety of tools are available, different student groups could use different construction methods. When students compare their answers for part c, students can discuss which construction methods are most accurate.*

*Note: In the previous task involving special right triangles, students were reminded that  $45^\circ$  angles occur when a square is bisected along the diagonal and that  $30^\circ$*

*angles occur when an angle in an equilateral triangle is bisected. Thus, they should be able to figure out that they can construct these two angles, one after the other, to make an angle of  $75^\circ$ , or construct a  $30^\circ$  inside a  $45^\circ$  with one side of the angle in common to get a difference of  $15^\circ$ .*

- c. Use similarity of the ramp triangle and measurements from your constructed triangle to find the length of the ramp. (Save the triangle and its measurements. You'll need them in the next Learning Task also.)

*Comment(s):*

*In class discussion of the solution, teachers should highlight the idea that we use the constructed triangle to find specific values for the lengths of the sides corresponding to the side of the ramp triangle that we know and to the side of the ramp triangle that we need to find. If students put the variable for unknown value in the numerator of one ratio (which is very likely), they will actually be using the cosecant ratio. However, we are not ready to name ratios. This part of the task just has students repeat the ideas from the first task to solve an everyday modern problem. Here students use measurements from a constructed triangle; much later in the unit they will use trigonometric ratios.*

*Of course, students are correct as long as they use the ratios of the corresponding sides. In class discussion of the solution, teachers need to question whether all students set up their ratios the same way and, if not, why there are alternate correct ways to set up the calculation.*

*However, the role of similarity is the most important concept to explore in class discussion. Students need to explore the fact that, although lots of different  $15^\circ$ - $75^\circ$ - $90^\circ$  are constructed by members of the class, they all should lead to the same answer. Students should agree that errors in measurement could lead to some variation in the answers and conclude that all answers should be close in value (as long as students use correct construction methods and are careful in measuring side lengths). Large variation in answers should be investigated.*

*One idea for following up on unavoidable error in measurement: have students work in groups and use the group's average value of the ratio of shortest side to hypotenuse for calculation of the ramp length.*

Solution(s):

*The ratio of shortest side to hypotenuse should be the same for both triangles.*

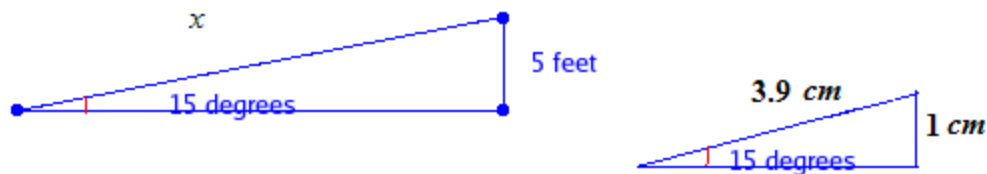

*In the constructed 15°- 75°- 90° right triangle shown above, the side opposite the 15° angle is 1 cm, and the length of the hypotenuse is 3.9 cm. Using the property that the ratio of two sides in one triangle is the same as the ratio of the corresponding sides in the other triangle, we have*

$$\frac{x}{5} = \frac{3.9}{1} \rightarrow x = 5(3.9) = 19.5.$$

*Thus, the ramp should be 19.5 feet long.*

3. Choose one of the types of right triangles that you described in *Item 1* and make up a problem similar to *Item 2* using this type of triangle. Also find an existing right triangle that you can measure; measure the angles and sides of this existing triangle, and then choose numbers for the problem you make up, so that the measurements of the existing triangle can be used to solve the problem. Pay careful attention to the information given in the ramp problem, and be sure to provide, and ask for, the same type of information in your problem.

Comment(s):

*Note that this item of the task asks students to make up a problem. It tells them to find a triangle to measure so that they do not restrict their problems to angle sizes that are easy to construct. The next part will ask students to exchange problems within their groups and solve the problems.*

*The direction to “be sure to use the same type of information about your triangle” is included, not to stifle creativity, but to require students to think of the relationships among parts of a right triangle. We want students to see that they have the degree measure of one of the acute angles of the right triangle and the length of the side opposite that angle. It is okay if students regard the relationship as shortest leg and opposite angle but not necessary. The point here is building a basis for the conceptual framework of right triangle trigonometry.*

*One strategy for this part of the task would be to assign it for homework so that class time can focus on Item 4. If teachers choose this strategy, it is recommended to have some additional problems, like the sample answer for this item, for use by students who do not bring in homework problems.*



*Another strategy is having students work in groups to construct problems and then exchange problems among groups. How students actually exchange problems and discuss their solutions can vary.*

*Solution(s):*

*An infinite number of responses are possible. A sample response is given below. In the sample problem, it is the relationship between the location of the given angle and the location of the given side, and not the orientation of the triangle, that makes it a problem similar to the ramp problem.*

4. Exchange the triangle problems from *Item 3* among the students in your class.
  - a. Each student should get the problem and a sketch of the existing right triangle (along with its measurements) from another student, and then solve the problem from the other student.

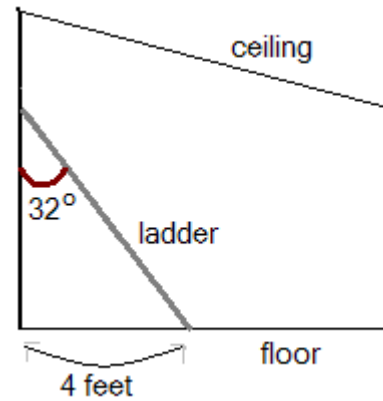

*Comment(s):*

*Depending on the class and whether Item 3 is given as homework or done in class, teachers may want to give more explicit instructions about how the problems should be exchanged.*

- b. For each problem, the person who made up the problem and the person who worked the problem should agree on the solution.

*Comment(s):*

*As they discuss and verify each others' work, students will reinforce the idea of using the ratio in a known triangle to solve for an unknown side of a similar triangle.*

Student Sample Work for *Finding Triangles in Your Environment*



## Finding Right Triangles in Your Environment Learning Task

### Standards Addressed in this Unit

**MGSE9-12.G.SRT.6** Understand that by similarity, side ratios in right triangles are properties of the angles in the triangle, leading to definitions of trigonometric ratios for acute angles.

**MGSE9-12.G.SRT.7** Explain and use the relationship between the sine and cosine of complementary angles.

**MGSE9-12.G.SRT.8** Use trigonometric ratios and the Pythagorean Theorem to solve right triangles in applied problems.

### Standards for Mathematical Practice

**1. Make sense of problems and persevere in solving them** by requiring students to interpret and make meaning of a problem and find a logical starting point, and to monitor their progress and change their approach to solving the problem, if necessary.

**2. Reason abstractly and quantitatively** by requiring students to make sense of quantities and their relationships to one another in problem situations.

**3. Construct viable arguments and critique the reasoning of others** by engaging students on discussion of why they agree or disagree with responses, decide whether they make sense, and ask useful questions to clarify or improve the arguments.

**4. Model with mathematics** by expecting students to apply the mathematics concepts they know in order to solve problems arising in everyday situations, and reflect on whether the results are sensible for the given scenario.

**5. Use appropriate tools strategically** by expecting students to consider available tools when solving a mathematical problem. These tools might include pencil and paper, concrete models, a ruler, a protractor, a compass, a calculator, software, etc.

**6. Attend to precision** by requiring students to calculate efficiently and accurately; and to communicate precisely with others by using clear mathematical language to discuss their reasoning.

**7. Look for and make use of structure** by expecting students to apply rules, look for patterns and analyze structure.

**8. Look for and express regularity in repeated reasoning** by expecting students to understand broader applications and look for structure and general methods in similar situations.

### Supplies needed

- Heavy stock, smooth unlined paper for constructing triangles (unlined index cards, white or pastel colors are a good choice)
- Compass and straight edge for constructing triangles

**Georgia Department of Education**  
Georgia Standards of Excellence Framework  
*GSE Geometry • Unit 3*

- Protractor for verifying measures of angles
  - Ruler in centimeters for measuring sides of constructed triangles
1. Look around you in your room, your school, your neighborhood, or your city. Can you find right triangles in everyday objects? List at least ten right triangles that you find. Draw pictures of at least three of them, labeling the  $90^\circ$  angle that makes the triangle a right triangle.
  2. An older building in the school district sits on the side of a hill and is accessible from ground level on both the first and second floors. However, access at the second floor requires use of several stairs. Amanda and Tom have been given the task of designing a ramp so that people who cannot use stairs can get into the building on the second floor level. The rise has to be 5 feet, and the angle of the ramp has to be 15 degrees.

- a. Tom and Amanda need to determine how long that ramp should be. One way to do this is to use a compass and straightedge to construct a  $15^\circ$ - $75^\circ$ - $90^\circ$  triangle on your paper. Such a triangle must be similar to the triangle defining the ramp. **Explain why the triangles are similar.**



*The diagram is not to scale.*

- b. Construct a  $15^\circ$ - $75^\circ$ - $90^\circ$  triangle on your paper using straightedge and compass. Use a protractor to verify the angle measurements. (Alternative: If dynamic geometry software is available, the construction and verification of angle measurements can be done using the software.) You'll use this triangle in *part c*.
  - c. Use similarity of the ramp triangle and measurements from your constructed triangle to find the length of the ramp. (Save the triangle and its measurements. You'll need them in another Learning Task also.)
3. Choose one of the types of right triangles that you described in *Item 1* and make up a problem similar to *Item 2* using this type of triangle. Also find an existing right triangle that you can measure; measure the angles and sides of this existing triangle, and then choose numbers for the problem you make up, so that the measurements of the existing triangle can be used to solve the problem. Pay careful attention to the information given in the ramp problem, and be sure to provide, and ask for, the same type of information in your problem.
  4. Exchange the triangle problems from *Item 3* among the students in your class.
    - a. Each student should get the problem and a sketch of the existing right triangle (along with its measurements) from another student, and then solve the problem from the other student.
    - b. For each problem, the person who made up the problem and the person who worked the problem should agree on the solution.

## ACCESS RAMP (Career and Technical Education Task)

Source: National Association of State Directors of Career Technical Education Consortium

PDF: <http://www.achieve.org/files/CCSS-CTE-Task-AccessRamp-FINAL.pdf>

Word: <http://www.achieve.org/files/CCSS-CTE-Task-AccessRamp-FINAL.docx>

### Introduction

Students are commissioned to design an access ramp, which complies with the American with Disabilities Act requirements.

### Standard Addressed in this Task

**MGSE9-12.G.SRT.8** Use trigonometric ratios and the Pythagorean Theorem to solve right triangles in applied problems.

### Standards for Mathematical Practice

- 1. Make sense of problems and persevere in solving them** by requiring students to make sense of the problem and determine an approach.
- 2. Reason abstractly and quantitatively** by requiring students to reason about quantities and what they mean within the context of the problem.
- 3. Construct viable arguments and critique the reasoning of others** by engaging students on discussion of why they agree or disagree with responses, decide whether they make sense, and ask useful questions to clarify or improve the arguments.
- 4. Model with mathematics** by expecting students to utilize mathematics to model situations.
- 6. Attend to precision** by expecting students to attend to units as they perform calculations. Rounding and estimation are a key part.

### Common Student Misconceptions

1. Some students believe that right triangles must be oriented a particular way.
2. Some students do not realize that opposite and adjacent sides need to be identified with reference to a particular acute angle in a right triangle.
3. Some students believe that the trigonometric ratios defined in this cluster apply to all triangles, but they are only defined for acute angles in right triangles.

## MINIATURE GOLF (Career and Technical Education Task)

Source: National Association of State Directors of Career Technical Education Consortium

PDF: <http://www.achieve.org/files/CCSS-CTE-Task-MiniatureGolf-FINAL.pdf>

Word: <http://www.achieve.org/files/CCSS-CTE-Task-MiniatureGolf-FINAL.docx>

### Introduction

Students are to design a miniature golf hole for a contest at the local miniature golf course.

### Standard Addressed in this Task

**MGSE9-12.G.SRT.8** Use trigonometric ratios and the Pythagorean Theorem to solve right triangles in applied problems.

### Standards for Mathematical Practice

- 1. Make sense of problems and persevere in solving them** by requiring students to make sense of the problem and determine an approach.
- 2. Reason abstractly and quantitatively** by requiring students to reason about quantities and what they mean within the context of the problem.
- 3. Construct viable arguments and critique the reasoning of others** by engaging students on discussion of why they agree or disagree with responses, decide whether they make sense, and ask useful questions to clarify or improve the arguments.
- 4. Model with mathematics** by expecting students to utilize mathematics to model situations.
- 5. Use appropriate tools strategically** by requiring students to determine the most appropriate tool in order to solve the problem.
- 6. Attend to precision** by expecting students to attend to units as they perform calculations. Rounding and estimation are a key part.

### Common Student Misconceptions

1. Some students believe that right triangles must be oriented a particular way.
2. Some students do not realize that opposite and adjacent sides need to be identified with reference to a particular acute angle in a right triangle.
3. Some students believe that the trigonometric ratios defined in this cluster apply to all triangles, but they are only defined for acute angles in right triangles.

## RANGE OF MOTION (Career and Technical Education Task)

Source: National Association of State Directors of Career Technical Education Consortium

PDF: <http://www.achieve.org/files/CCSS-CTE-Task-Range-of-Motion-FINAL.pdf>

Word: <http://www.achieve.org/files/CCSS-CTE-Task-Range-of-Motion-FINAL.doc>

### Introduction

Students are to track a patient's physical therapy to increase his active range of motion of his arm.

### Standard Addressed in this Task

**MGSE9-12.G.SRT.8** Use trigonometric ratios and the Pythagorean Theorem to solve right triangles in applied problems.

### Standards for Mathematical Practice

- 1. Make sense of problems and persevere in solving them** by requiring students to make sense of the problem and determine an approach.
- 2. Reason abstractly and quantitatively** by requiring students to reason about quantities and what they mean within the context of the problem.
- 6. Attend to precision** by expecting students to attend to units as they perform calculations. Rounding and estimation are a key part.

### Common Student Misconceptions

1. Some students believe that right triangles must be oriented a particular way.
2. Some students do not realize that opposite and adjacent sides need to be identified with reference to a particular acute angle in a right triangle.
3. Some students believe that the trigonometric ratios defined in this cluster apply to all triangles, but they are only defined for acute angles in right triangles.

## Create Your Own Triangles Learning Task

### Supplies needed

- Heavy stock, smooth unlined paper for constructing triangles (unlined index cards, white or pastel colors are a good choice)
- Unlined paper (if students construct triangles in groups and need individual copies)
- Compass and straight edge for constructing triangles
- Protractor for verifying measures of angles
- Ruler in centimeters for measuring sides of constructed triangles

### **Standards Addressed in this Unit**

**MGSE9-12.G.SRT.6** Understand that by similarity, side ratios in right triangles are properties of the angles in the triangle, leading to definitions of trigonometric ratios for acute angles.

**MGSE9-12.G.SRT.7** Explain and use the relationship between the sine and cosine of complementary angles.

**MGSE9-12.G.SRT.8** Use trigonometric ratios and the Pythagorean Theorem to solve right triangles in applied problems.

### **Standards of Mathematical Practice**

- 1. Make sense of problems and persevere in solving them** by requiring students to interpret and make meaning of a problem and find a logical starting point, and to monitor their progress and change their approach to solving the problem, if necessary.
- 2. Reason abstractly and quantitatively** by requiring students to make sense of quantities and their relationships to one another in problem situations.
- 3. Construct viable arguments and critique the reasoning of others** by engaging students on discussion of why they agree or disagree with responses, decide whether they make sense, and ask useful questions to clarify or improve the arguments.
- 4. Model with mathematics** by expecting students to apply the mathematics concepts they know in order to solve problems arising in everyday situations, and reflect on whether the results are sensible for the given scenario.
- 5. Use appropriate tools strategically** by expecting students to consider available tools when solving a mathematical problem. These tools might include pencil and paper, concrete models, a ruler, a protractor, a compass, a calculator, software, etc.
- 6. Attend to precision** by requiring students to calculate efficiently and accurately; and to communicate precisely with others by using clear mathematical language to discuss their reasoning.



**7. Look for and make use of structure** by expecting students to apply rules, look for patterns and analyze structure.

**8. Look for and express regularity in repeated reasoning** by expecting students to understand broader applications and look for structure and general methods in similar situations.

**Common Student Misconceptions**

1. Some students believe that right triangles must be oriented a particular way.
2. Some students do not realize that opposite and adjacent sides need to be identified with reference to a particular acute angle in a right triangle.
3. Some students believe that the trigonometric ratios defined in this cluster apply to all triangles, but they are only defined for acute angles in right triangles.

**Comments**

*Students use compass and straightedge constructions along with protractor measurements to make nine right triangles that include all possible acute angles whose measures are multiples of  $5^\circ$ . The definitions of the sine and cosine ratios for any acute angle are given, and students use their constructed triangles to make their own tables of values for the functions.*

1. Using construction paper, compass, straightedge, protractor, and scissors, make and cut out nine right triangles. One right triangle should have an acute angle of  $5^\circ$ , the next should have an acute angle of  $10^\circ$ , and so forth, all the way up to  $45^\circ$ . Note that you should already have a constructed right triangle with an angle of  $15^\circ$  that you saved from the *Finding Right Triangles in the Environment Learning Task*. You use it or make a new one to have all nine triangles.

As you make the triangles, you should construct the right angles and, whenever possible, construct the required acute angle. You can use the protractor in creating your best approximation of those angles, such as  $5^\circ$ , for which there is no compass and straightedge construction or use alternate methods involving a marked straightedge.

**As you make your triangles, label both acute angles with their measurements in degrees and label all three sides with their measurement in centimeters to the nearest tenth of a centimeter.**

Comment(s):

*The activity of constructing the 15°- 75°- 90° right triangle in the previous task introduced students to the idea of constructing right triangles that include particular acute angles and allowed them to review straightedge and compass construction techniques. Note that the instruction for this item tells students to “make and cut out” the triangles. They are instructed to cut out the triangles because they are likely to measure the sides more accurately if the triangles are cut out. They are told to “make” the triangles rather than “construct” them in order to avoid misleading the students. Students can construct all the needed angles whose measures are multiples of 15°. Once they have a 5° or 10° angle, they can use these to make the other needed angles. Mathematicians have proved that it is impossible to trisect an angle using only straightedge and compass, so students cannot “construct” a 5° or 10° angle by trisecting a 15° or 30°. So what are students to do?*

*There are two major alternatives for obtaining a 5° or 10° angle: (1) have students use protractors in drawing angles that are as close to the desired measurements as possible or (2) use construction technique discovered by Archimedes that allows marking lengths on the straight edge. (See Optional Angle Trisection Notes below.) If time permits, the second method is recommended for its geometric richness. When using this method, there is an optional extension for strong students: Prove why the construction gives a trisected angle. However, using protractors is fine as long as students understand that their triangles will not have the same accuracy of a well-executed construction.*

*Teachers also have latitude in how to organize student work on Item 1. To ensure that students have the materials to create the triangles, this part of the task should be done in the classroom, but whether each student makes her or his set of nine triangles or whether students work together in groups to make triangles depends on time and dynamics of the classroom. In general, it will probably be sufficient to have each group of two – four students make one set of triangles that can be maintained in a classroom file.*

*If the option of group construction is implemented, then each student in the group should also make her or his own reference sheet by using the constructed triangles to make a sketch of each triangle, with all measurements from the constructed triangle recorded on the sketch. Students should do this on unlined paper since the lines of notebook paper are a distraction for viewing the triangles. With this reference sheet, students can begin Item 2 in class but complete it for homework, if necessary*

## Optional Notes on Angle Trisection:

Comment(s):

*The figure below shows the key ideas for this method and was created by Dr. Steve Dutch at the University of Wisconsin Bay and found on his extensive website: <http://www.uwgb.edu/dutchs/PSEUDOSC/trisect.HTM>. A proof that the method*

*trisects the angle is available at this site. The site also includes other methods of angle trisection. The Wikipedia entry for “Trisecting an Angle” provides similar information and has a gif “video” showing the construction of an angle bisector: [http://en.wikipedia.org/wiki/Angle\\_trisection](http://en.wikipedia.org/wiki/Angle_trisection) .*

*Note that the step of positioning the marked straightedge requires “eyeballing” the line to the desired position and, thus, lacks the precision of a straightedge and compass construction.*

*Angle AOX is the angle to be trisected. Construct a circle centered at O. Extend ray  $\overrightarrow{OX}$  to form a line, and D be the other endpoint of the diagonal of the circle containing segment OX,*

*Mark the length of segment OX on the straight edge and label the marks B and C as shown on the yellow straight edge image.*

*Position the straightedge so that the mark at B lies on line DOX, the mark at C lies on the circle, and the straightedge passes through the point A where the side of the original angle intersects the circle. Draw the line segment BC. Angle CBD is one-third of AOX.*

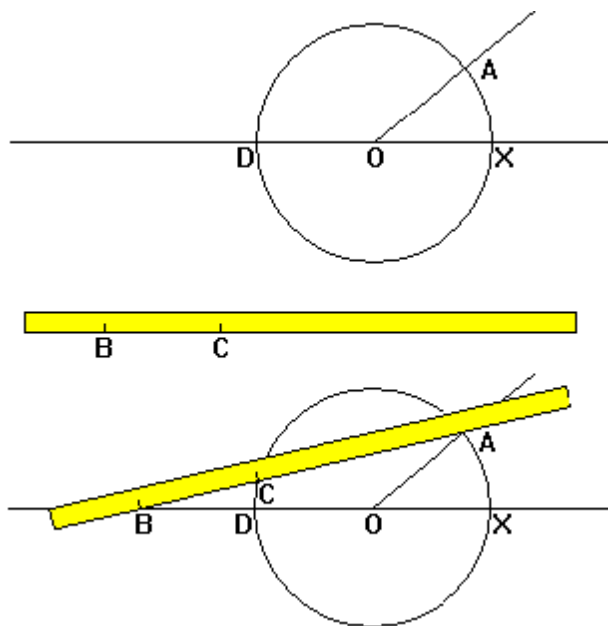

*Using what we found to be true about ratios from similar right triangles in the Circumference of the Earth Task, we are now ready to define some very important new functions. For any acute angle in a right triangle, we denote the measure of the angle by  $\theta$  and define two numbers related to  $\theta$  as follows:*

$$\text{sine of } \theta = \frac{\text{length of leg opposite the vertex of the angle}}{\text{length of hypotenuse}}$$

$$\text{cosine of } \theta = \frac{\text{length of leg adjacent to the vertex of the angle}}{\text{length of hypotenuse}}$$

In the figure at the right below, the terms “opposite,” “adjacent,” and “hypotenuse” are used as shorthand for the lengths of these sides. Using this shorthand, we can give abbreviated versions of the above definitions:

$$\text{sine of } \theta = \frac{\text{opposite}}{\text{hypotenuse}}$$

$$\text{cosine of } \theta = \frac{\text{adjacent}}{\text{hypotenuse}}$$

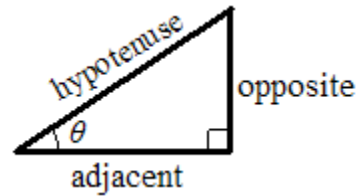

Comment(s):

At this point, the focus is defining the trigonometric ratios and understanding why these definitions give unique outputs for each input angle. **NO CALCULATOR VALUES OF TRIG FUNCTIONS are to be discussed at this time.**

- Using the measurements from the triangles that you created in doing *Item 1* above, for each acute angle listed in the table below, complete the row for that angle. The first three columns refer to the lengths of the sides of the triangle; the last columns are for the sine of the angle and the cosine of the angle. Remember that which side is opposite or adjacent depends on which angle you are considering. (Hint: For angles greater than  $45^\circ$ , try turning your triangles sideways.)  
For the last three columns, write your table entries as fractions (proper or improper, as necessary, but no decimals in the fractions).

Solution(s):

Students should be encouraged to measure as accurately as they can and record their measurements accurately. The values for some constructed triangles are included below. The  $10^\circ$  angle was constructed using the optional method with marked straightedge, and the  $5^\circ$  angle was then obtained by bisecting the  $10^\circ$  angle. As expected, in most cases, measurements to the nearest tenth of a centimeter give trigonometric ratios that approximate the theoretical values reasonably well, usually within a few hundredths of their theoretical values. Note that sine, and cosine values have no units since the “cm” cancels in calculating the ratio.

Any class discussion of comparison of entries in Table 1 (student to student or to known values) needs to wait until the items below that instruct students to compare and discuss.

**Georgia Department of Education**  
 Georgia Standards of Excellence Framework  
*GSE Geometry • Unit 3*

*Students will be asked to compare and discuss tables' entries across the class in the next few items. They will be asked to compare the values in their tables to values from the calculator at the beginning of the applications task.*

**TABLE 1** (*Entries illustrate the types of entries students should have and are used in giving sample solutions for later items in this task and the next*)

<i>angle measure</i>	<i>opposite</i>	<i>adjacent</i>	<i>hypotenuse</i>	<i>sine (opp/hyp)</i>	<i>cosine (adj/hyp)</i>
5°	0.7 cm	8.3 cm	8.4 cm	$\frac{7}{84} = \frac{1}{12}$	$\frac{83}{84}$
10°	1.5 cm	8.3 cm	8.5 cm	$\frac{15}{85} = \frac{3}{17}$	$\frac{83}{85}$
15°	3.1 cm	12.8 cm	13.2 cm	$\frac{31}{132}$	$\frac{128}{132} = \frac{32}{33}$
20°					
25°					
30°	2.2 cm	3.7 cm	4.4 cm	$\frac{22}{44} = \frac{1}{2}$	$\frac{37}{44}$
35°					
40°					
45°	3.1 cm	3.1 cm	4.4 cm	$\frac{31}{44}$	$\frac{31}{44}$
50°					
55°					
60°	3.7 cm	2.2 cm	4.4 cm	$\frac{37}{44}$	$\frac{22}{44} = \frac{1}{2}$
65°					
70°					
75°	12.8 cm	3.1 cm	13.2 cm	$\frac{128}{132} = \frac{32}{33}$	$\frac{31}{132}$
80°	8.3 cm	1.5 cm	8.5 cm	$\frac{83}{85}$	$\frac{15}{85} = \frac{3}{17}$



**Georgia Department of Education**  
 Georgia Standards of Excellence Framework  
*GSE Geometry • Unit 3*

<i>angle measure</i>	<i>opposite</i>	<i>adjacent</i>	<i>hypotenuse</i>	<i>sine</i> ( <i>opp/hyp</i> )	<i>cosine</i> ( <i>adj/hyp</i> )
85°	8.3 cm	0.7 cm	8.4 cm	$\frac{83}{84}$	$\frac{7}{84} = \frac{1}{12}$

3. Look back at the *Discovering Special Triangles Learning Task, Item 4*.

*Comment(s):*

*This item and the next one are designed to accomplish three things. First, as they work through these two items, students will understand how their knowledge of special right triangles allows them to give exact answers for the trigonometric ratios of the acute angles in these triangles. Second, students will seek explanations for any differences between entries in Table 1 and these exact values. Third, students should conclude that differences in values are due to inaccuracy of precision in the construction process and/or lack of precision due to measuring only to the nearest tenth of a centimeter and, hence, begin to realize that the trigonometric ratios for the other angles also have exact values for which their Table 1 entries are just approximations (of course, some will be better than others).*

- a. Use the lengths in the first row of the table from *Item 4* of that learning task to find the values of sine and cosine to complete the **Table 2** below.

*Solution(s):*

**TABLE 2**

<i>angle</i>	<i>sine</i>	<i>cosine</i>
30°	$\frac{1}{2}$	$\frac{\sqrt{3}}{2}$

- b. All right triangles with a 30° angle should give the same values for the sine and cosine ratios as those in **Table 2**. Why?

*Solution(s):*

*In any right triangle with an angle of 30°, the other acute angle must measure 60°. So, any right triangle with a 30° angle must be a 30°-60°-90° right triangle. All of these triangles are similar. In the Discovering Special Triangles Learning Task, we concluded that, in any 30°-60°-90° right triangle, the lengths of the hypotenuse,*

*shorter leg, and longer leg follow the pattern  $2a, a, a\sqrt{3}$  and so the values of the trigonometric ratios must always be:*

$$\text{sine of } 30^\circ = \frac{a}{2a} = \frac{1}{2}, \quad \text{cosine of } 30^\circ = \frac{a\sqrt{3}}{2a} = \frac{\sqrt{3}}{2}$$

*These are the same values as in Table 2 because the Table 2 values were calculated using one specific set of values that can be the sides of a  $30^\circ$ - $60^\circ$ - $90^\circ$  right triangle.*

- c. Do the values for the sine and cosine of a  $30^\circ$  angle that you found for **Table 1** (by using measurements from a constructed triangle) agree with the values you found for the sine and cosine, of a  $30^\circ$  angle in **Table 2**? If they are different, why doesn't this contradict *part b*?

*Solution(s):*

*The value for sine agrees with the values from part a, but the cosine does not agree.*

$$\text{cosine of } 30^\circ = \frac{\sqrt{3}}{2} \approx 0.8660; \quad \text{value from constructed triangle} = \frac{37}{44} \approx 0.8409$$

*The actual value of the cosine of  $30^\circ$  is approximately 0.0251 greater than the value found using the constructed triangle.*

*The values in Table 2 are exact. The values found in my constructed triangle are just approximations of these exact values and can differ for several reasons related to the construction process.*

- A constructed triangle is not exact due to the difficulty in constructing angles that are exactly  $90^\circ$  and exactly  $30^\circ$ . The angles are likely a fraction of a degree off.*
- Measurements of lengths are to the nearest tenth of a centimeter (the nearest millimeter). The exact measurement would be different, and more precise measuring instruments would likely give values closer to the actual value.*
- There is the possibility of human error in drawing construction lines or in reading the measurements of the lengths of the side*

4. Look back at the *Discovering Special Triangles Learning Task, Item 8*.
- a. Use the table values from *Item 8, part a*, to complete the table below with **exact values** of sine and cosine for an angle of  $45^\circ$ .

*Solution(s):*

**TABLE 3**

<i>angle</i>	<i>sine</i>	<i>cosine</i>
$45^\circ$	$\frac{1}{\sqrt{2}}$	$\frac{1}{\sqrt{2}}$

- b. How do the values of sine and cosine that you found for Table 1 compare to the exact values from *part a*? What can you conclude about the accuracy of your construction and measurements?

Solution(s):

*sine, and cosine, of  $45^\circ = \frac{\sqrt{2}}{2} \approx 0.7071$ ; constructed triangle value =  $\frac{31}{44} \approx 0.7045$*

*The actual value of the sine and cosine of  $45^\circ$  is approximately 0.0026 greater than the value found using the constructed triangle.*

*That the values are so close indicates good accuracy in construction and measurement.*

5. If T is any right triangle with an angle of  $80^\circ$ , approximately what is the ratio of the opposite side to the hypotenuse? Explain.

Comment(s):

*This part and the next are designed to reinforce the idea that the values in Table 1 are approximations of exact values that theoretically must exist. Every student's answer to the question above should be that the value is approximately the one in my Table 1 for that quantity. Across the class there will be variation in the approximations, so some kind of comparison across the class is a natural activity. One is suggested in the next paragraph. After students compare their data, they need to come back to the idea that there is only one exact value since all the right triangles with an  $80^\circ$  angle are similar.*

Suggested data comparison activity

*This item is the prompt for students to compare their values and provides an excellent opportunity for students to use data analysis in a situation of concern to them. Each student could be assigned a different trigonometric ratio, for example, the cosine of  $35^\circ$ , and should be responsible for collecting a list of all the values (as fractions) that students in the class found from their constructed triangles and entered in Table 1. Students could then be assigned to put their lists in L1 of their calculators and run one-variable statistics to get the five-number summary of minimum, first quartile, mean, third quartile, and maximum. The class could make a chart of this data, and students could compare their values to see where their values fall.*

Solution(s):

*The ratio is approximately the value given in TABLE 1 for an  $80^\circ$  angle. How good that approximation will vary from student to student.*

*In any right triangle with an angle of  $80^\circ$ , the other acute angle must measure  $10^\circ$ . So, any right triangle with a  $80^\circ$  angle must be a  $10^\circ$ - $80^\circ$ - $90^\circ$  right triangle; that is, all of these triangles are similar by angle-angle-angle. Since all these triangles are similar, the ratio of the length of the side opposite the  $80^\circ$  angle to the length of the hypotenuse is the same no matter which triangle. When we use constructed triangles and measure lengths to the nearest tenth of an inch, our measurements are approximations of the exact side lengths so our ratios are approximations of the exact ratio value.*

6. If we changed the measure of the angle in *Item 5* to another acute angle measure, how would your answer change?

*Solution(s):*

*The answer would change by using the other acute angle measure in place of  $80^\circ$  and using the complement of the other acute angle measure in place of  $10^\circ$ . Otherwise, the answer would not change.*

7. Explain why the trigonometric ratios of sine and cosine define **functions of  $\theta$ , where  $0^\circ < \theta < 90^\circ$** .

*Solution(s):*

*Generalizing the responses to items 3 – 6: for any acute angle in a right triangle of measure  $\theta$ , the other acute angle in the triangle must have measure  $90^\circ - \theta$ . So, all right triangles with an acute angle of measure  $\theta$  are similar. For similar triangles, the ratio of the lengths of two particular sides in one triangle is the same as the ratio of the lengths of the corresponding sides in any other similar right triangle. Thus, the ratio does not depend on the triangle we use; the ratio depends only on the measure of the angle. Acute angles in a right triangle measure between  $0^\circ$  and  $90^\circ$ .*

*Hence, for any  $\theta$  greater than  $0^\circ$  and less than  $90^\circ$ ,  $\theta$  is the measure of an acute angle in a right triangle, and there is a unique value for the sine and a unique value for the cosine. When each input gives a unique output, we have a function. Thus, each of sine and cosine is a function of  $\theta$ , for any  $\theta$  greater than  $0^\circ$  and less than  $90^\circ$ .*

8. Are the functions sine and cosine linear functions? Why or why not?

*Comment(s):*

*Students will not study graphs of trigonometric functions until later, so they will not see that these functions are non-linear. It is a good idea for them to realize that these trigonometric functions are not linear before they begin to use them extensively.*

*Solution(s):*

*None of these functions is linear.*

**Georgia Department of Education**  
 Georgia Standards of Excellence Framework  
*GSE Geometry • Unit 3*

*In the table below, we have chosen equal changes in the degree measures for the inputs in the cases where the function values are known exactly. If any of the functions were linear, the outputs for that function would change by the same amount, but they are not, as shown in the table of differences below.*

<i>angle measure</i>	<i>sine (opp/hyp)</i>		<i>cosine (adj/hyp)</i>	
30°	$\frac{1}{2}$		$\frac{\sqrt{3}}{2}$	
		$\approx 0.2071$		$\approx -0.1589$
45°	$\frac{1}{\sqrt{2}}$		$\frac{1}{\sqrt{2}}$	
		$\approx 0.1589$		$\approx -0.2071$
60°	$\frac{\sqrt{3}}{2}$		$\frac{1}{2}$	

## Create Your Own Triangles Learning Task

### Supplies needed

- Heavy stock, smooth unlined paper for constructing triangles (unlined index cards, white or pastel colors are a good choice)
- Unlined paper (if students construct triangles in groups and need individual copies)
- Compass and straight edge for constructing triangles
- Protractor for verifying measures of angles
- Ruler in centimeters for measuring sides of constructed triangles

### **Standards Addressed in this Unit**

**MGSE9-12.G.SRT.6** Understand that by similarity, side ratios in right triangles are properties of the angles in the triangle, leading to definitions of trigonometric ratios for acute angles.

**MGSE9-12.G.SRT.7** Explain and use the relationship between the sine and cosine of complementary angles.

**MGSE9-12.G.SRT.8** Use trigonometric ratios and the Pythagorean Theorem to solve right triangles in applied problems.

### **Standards for Mathematical Practice**

- 1. Make sense of problems and persevere in solving them** by requiring students to interpret and make meaning of a problem and find a logical starting point, and to monitor their progress and change their approach to solving the problem, if necessary.
- 2. Reason abstractly and quantitatively** by requiring students to make sense of quantities and their relationships to one another in problem situations.
- 3. Construct viable arguments and critique the reasoning of others** by engaging students on discussion of why they agree or disagree with responses, decide whether they make sense, and ask useful questions to clarify or improve the arguments.
- 4. Model with mathematics** by expecting students to apply the mathematics concepts they know in order to solve problems arising in everyday situations, and reflect on whether the results are sensible for the given scenario.
- 5. Use appropriate tools strategically** by expecting students to consider available tools when solving a mathematical problem. These tools might include pencil and paper, concrete models, a ruler, a protractor, a compass, a calculator, software, etc.
- 6. Attend to precision** by requiring students to calculate efficiently and accurately; and to communicate precisely with others by using clear mathematical language to discuss their reasoning.



**7. Look for and make use of structure** by expecting students to apply rules, look for patterns and analyze structure.

**8. Look for and express regularity in repeated reasoning** by expecting students to understand broader applications and look for structure and general methods in similar situations.

1. Using construction paper, compass, straightedge, protractor, and scissors, make and cut out nine right triangles. One right triangle should have an acute angle of  $5^\circ$ , the next should have an acute angle of  $10^\circ$ , and so forth, all the way up to  $45^\circ$ . Note that you should already have a constructed right triangle with an angle of  $15^\circ$  that you saved from the *Finding Right Triangles in the Environment Learning Task*. You can use it or make a new one to have all nine triangles.

As you make the triangles, you should construct the right angles and, whenever possible, construct the required acute angle. You can use the protractor in creating your best approximation of those angles, such as  $5^\circ$ , for which there is no compass and straightedge construction or use alternate methods involving a marked straightedge.

**As you make your triangles, label both acute angles with their measurements in degrees and label all three sides with their measurement in centimeters to the nearest tenth of a centimeter.**

Using what we found to be true about ratios from similar right triangles in the *Circumference of the Earth Task*, we are now ready to define some very important new functions. **For any acute angle in a right triangle, we denote the measure of the angle by  $\theta$**  and define two numbers related to  $\theta$  as follows:

$$\text{sine of } \theta = \frac{\text{length of leg opposite the vertex of the angle}}{\text{length of hypotenuse}}$$

$$\text{cosine of } \theta = \frac{\text{length of leg adjacent to the vertex of the angle}}{\text{length of hypotenuse}}$$

In the figure at the right below, the terms “opposite,” “adjacent,” and “hypotenuse” are used as shorthand for the lengths of these sides. Using this shorthand, we can give abbreviated versions of the above definitions:

$$\text{sine of } \theta = \frac{\text{opposite}}{\text{hypotenuse}}$$

$$\text{cosine of } \theta = \frac{\text{adjacent}}{\text{hypotenuse}}$$

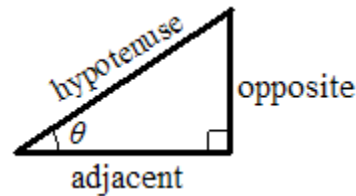

2. Using the measurements from the triangles that you created in doing *Item 1* above, for each acute angle listed in the table below, complete the row for that angle. The first three columns refer to the lengths of the sides of the triangle; the last columns are for the sine of the angle and the cosine of the angle. Remember that which side is opposite or adjacent depends on which angle you are considering. (Hint: For angles greater than  $45^\circ$ , try turning your triangles sideways.)  
For the last two columns, write your table entries as fractions (proper or improper, as necessary, but no decimals).

**Georgia Department of Education**  
 Georgia Standards of Excellence Framework  
*GSE Geometry • Unit 3*

**TABLE 1**

<i>angle measure</i>	<i>opposite</i>	<i>adjacent</i>	<i>hypotenuse</i>	<i>sine (opp/hyp)</i>	<i>cosine (adj/hyp)</i>
5°					
10°					
15°					
20°					
25°					
30°					
35°					
40°					
45°					
50°					
55°					
60°					
65°					
70°					
75°					
80°					
85°					

3. Look back at the *Discovering Special Triangles Learning Task, Item 4*.
- a. Use the lengths in the first row of the table from *Item 4* of that learning task to find the values of sine and cosine to complete the **Table 2** below.

**TABLE 2.**

<i>angle</i>	<i>sine</i>	<i>cosine</i>
30°		

- b. All right triangles with a 30° angle should give the same values for the sine and cosine ratios as those in **Table 2**. Why?
- c. Do the values for the sine and cosine of a 30° angle that you found for **Table 1** (by using measurements from a constructed triangle) agree with the values you found for the sine and cosine of a 30° angle in **Table 2**? If they are different, why does this not contradict *part b*?
4. Look back at the *Discovering Special Triangles Learning Task, Item 8*.
- a. Use the table values from *Item 8, part a*, to complete the table below with **exact values** of sine and cosine for an angle of 45°.

**TABLE 3**

<i>angle</i>	<i>sine</i>	<i>cosine</i>
45°		

- b. How do the values of sine and cosine that you found for Table 1 compare to the exact values from *part a*? What can you conclude about the accuracy of your construction and measurements?

**Georgia Department of Education**  
Georgia Standards of Excellence Framework  
*GSE Geometry • Unit 3*

5. If  $T$  is any right triangle with an angle of  $80^\circ$ , approximately what is the ratio of the opposite side to the hypotenuse? Explain.
  
6. If we changed the measure of the angle in *Item 5* to another acute angle measure, how would your answer change?
  
7. Explain why the trigonometric ratios of sine and cosine define **functions of  $\theta$ , where  $0^\circ < \theta < 90^\circ$** .
  
8. Are the functions sine and cosine linear functions? Why or why not?

## Triangular Frameworks (Short Cycle Task)

Source: *Balanced Assessment Materials from Mathematics Assessment Project*

<http://www.map.mathshell.org/materials/download.php?fileid=814>

### **ESSENTIAL QUESTIONS:**

- How do you draw, construct, and describe geometric figures and describe the relationships between them?

### **TASK COMMENTS:**

Tasks and lessons from the Mathematics Assessment Project are specifically designed to help teachers effectively formatively assess their students. The way the tasks and lessons are designed gives the teacher a clear understanding of what the students are able to do and not do. Within the lesson, teachers will find suggestions and question prompts that will help guide students towards understanding. For more information access the MAP website:

<http://www.map.mathshell.org/materials/background.php?subpage=summative>

The task, *Triangular Frameworks*, is a Mathematics Assessment Project Assessment Task that can be found at the website:

<http://www.map.mathshell.org/materials/tasks.php?taskid=281&subpage=expert>

The PDF version of the task can be found at the link below:

<http://www.map.mathshell.org/materials/download.php?fileid=814>

The scoring rubric can be found at the following link:

<http://www.map.mathshell.org/materials/download.php?fileid=815>

### **STANDARDS ADDRESSED IN THIS TASK:**

#### **Define trigonometric ratios and solve problems involving right triangles.**

**MGSE9-12.G.SRT.6** Understand that by similarity, side ratios in right triangles are properties of the angles in the triangle, leading to definitions of trigonometric ratios for acute angles.

**MGSE9-12.G.SRT.7** Explain and use the relationship between the sine and cosine of complementary angles.

**MGSE9-12.G.SRT.8** Use trigonometric ratios and the Pythagorean Theorem to solve right triangles in applied problems.

#### **Standards for Mathematical Practice**

This task uses all of the practices with emphasis on:

**2. Reason abstractly and quantitatively** by requiring students to make sense of quantities and their relationships to one another in problem situations.



**3. Construct viable arguments and critique the reasoning of others** by engaging students on discussion of why they agree or disagree with responses, decide whether they make sense, and ask useful questions to clarify or improve the arguments.

**6. Attend to precision** by requiring students to calculate efficiently and accurately; and to communicate precisely with others by using clear mathematical language to discuss their reasoning.

**7. Look for and make use of structure** by expecting students to apply rules, look for patterns and analyze structure.

## Discovering Trigonometric Ratio Relationships

### Standards Addressed in this Unit

**MGSE9-12.G.SRT.7** Explain and use the relationship between the sine and cosine of complementary angles.

### Standards of Mathematical Practice

**2. Reason abstractly and quantitatively** by requiring students to make sense of quantities and their relationships to one another in problem situations.

**3. Construct viable arguments and critique the reasoning of others** by engaging students on discussion of why they agree or disagree with responses, decide whether they make sense, and ask useful questions to clarify or improve the arguments.

### Common Student Misconceptions

1. Some students believe that right triangles must be oriented a particular way.
2. Some students do not realize that opposite and adjacent sides need to be identified with reference to a particular acute angle in a right triangle.
3. Some students believe that the trigonometric ratios defined in this cluster apply to all triangles, but they are only defined for acute angles in right triangles.

Now that you have explored the trigonometric ratios and understand that they are functions which use degree measures of acute angles from right triangles as inputs, we can introduce some notation that makes it easier to work with these values.

We considered these abbreviated versions of the definitions earlier.

$$\text{sine of } \theta = \frac{\text{opposite}}{\text{hypotenuse}}$$

$$\text{cosine of } \theta = \frac{\text{adjacent}}{\text{hypotenuse}}$$

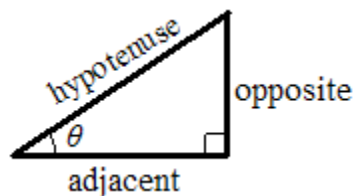

Now, we'll introduce the notation and abbreviate a bit more. In higher mathematics, the following notations are standard.

sine of  $\theta$  is denoted by  $\sin(\theta)$

cosine of  $\theta$  is denoted by  $\cos(\theta)$

### Comments

*Students explore trigonometric functions of complementary angles to find out that the sine of an acute angle in a right triangle is equal to the cosine of its complement. To help*

*students express these ideas clearly, the task also introduces the function notations of  $\sin(\theta)$  and  $\cos(\theta)$ .*

- Refer back to Table 1 from the *Create Your Own Triangles Learning Task*. Choose any one of the cut-out triangles created in the *Create Your Own Triangles Learning Task*. Identify the pair of complementary angles within the triangle. (Reminder: complementary angles add up to  $90^\circ$ .) Select a second triangle and identify the pair of complementary angles. Is there a set of complementary angles in every right triangle? Explain your reasoning.

*Solution(s):*

*The pairs are:  $5^\circ, 85^\circ$ ;  $10^\circ, 80^\circ$ ;  $15^\circ, 75^\circ$ ;  $20^\circ, 70^\circ$ ;  $25^\circ, 65^\circ$ ;  $30^\circ, 60^\circ$ ;  $35^\circ, 55^\circ$ ;  $40^\circ, 50^\circ$ ;  $45^\circ, 45^\circ$ .*

*Yes, there is a set of complementary angles in every right triangle because a right angle measures  $90^\circ$  and the sum of the measures of the angles in the triangle is  $180^\circ$ . Thus, the sum of the two other angles is  $90^\circ$ .*

- Use the two triangles you chose in *Item 2* to complete the table below. What relationships among the values do you notice? Do these relationships hold true for all pairs complementary angles in right triangles? Explain your reasoning.

*Solution(s):*

*The table below shows an example choice of triangles and, hence, pairs of complementary angles from the 36 possible choices of two of the nine triangles.*

triangle # and angle	$\theta$	$\sin(\theta)$	$\cos(\theta)$
1 – smaller angle	$10^\circ$	$\frac{3}{17}$	$\frac{83}{85}$
1 – larger angle	$80^\circ$	$\frac{83}{85}$	$\frac{3}{17}$
2 – smaller angle	$30^\circ$	$\frac{1}{2}$	$\frac{37}{44}$
2 – larger angle	$60^\circ$	$\frac{37}{44}$	$\frac{1}{2}$

*We notice that, for each pair of complementary angles in a right triangle, the sine of one angle is the cosine of its complement.*

*Yes, these relationships hold true for all pairs of complementary angles in right triangles.*

*Explaining why sine of one angle is the cosine of its complement:  
In a right triangle, there is only one hypotenuse, so this number stays the same whether we are calculating a sine or cosine. However, the side opposite one angle is adjacent to its complement in all right triangles with those angle pairs. Thus, sine = opp/hyp for one angle is the same as cosine = adj/hyp for its complement, and vice versa.*

Summarize the relationships you stated in *Item 3*.

- a. If  $\theta$  is the degree measure of an acute angle in a right triangle, what is the measure of its complement?

*Solution(s):*

*degree measure of the complement of the angle with degree measure  $\theta$ :  $90^\circ - \theta$*

- b. State the relationships from *Item 3* as identity equations involving sines and cosines of  $\theta$  and the measure of its complement. Use the expression from *part a*.

*Comment(s):*

*Since complementary angles come in pairs where each angle is the complement of the other, we can think of  $\theta$  as the measure of the angle and think of  $90^\circ - \theta$ , or we can let  $90^\circ - \theta$  represent the measure of the angle and let  $\theta$  represent the measure of its complement. This duality leads to the two versions of the relationship between sine and cosine of complementary angles. Students will write one or the other; class discussion can confirm that it is worthwhile to write both of them for completeness sake.*

*Solution(s):*

*sine of an acute angle in a right triangle is the cosine of its complement:*

$$\sin(\theta) = \cos(90^\circ - \theta)$$

*cosine of an acute angle in a right triangle is the sine of its complement:*

$$\cos(\theta) = \sin(90^\circ - \theta)$$

## Discovering Trigonometric Ratio Relationships

### Standards Addressed in this Unit

**MGSE9-12.G.SRT.7** Explain and use the relationship between the sine and cosine of complementary angles.

### Standards of Mathematical Practice

**2. Reason abstractly and quantitatively** by requiring students to make sense of quantities and their relationships to one another in problem situations.

**3. Construct viable arguments and critique the reasoning of others** by engaging students on discussion of why they agree or disagree with responses, decide whether they make sense, and ask useful questions to clarify or improve the arguments.

Now that you have explored the trigonometric ratios and understand that they are functions which use degree measures of acute angles from right triangles as inputs, we can introduce some notation that makes it easier to work with these values.

We considered these abbreviated versions of the definitions earlier.

$$\text{sine of } \theta = \frac{\text{opposite}}{\text{hypotenuse}}$$

$$\text{cosine of } \theta = \frac{\text{adjacent}}{\text{hypotenuse}}$$

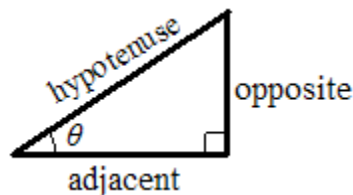

Now, we'll introduce the notation and abbreviate a bit more. In higher mathematics, the following notations are standard.

sine of  $\theta$  is denoted by  $\sin(\theta)$

cosine of  $\theta$  is denoted by  $\cos(\theta)$

1. Refer back Table 1 from the *Create Your Own Triangles Learning Task*. Choose any one of the cut-out triangles created in the *Create Your Own Triangles Learning Task*. Identify the pair of complementary angles within the triangle. (Reminder: complementary angles add up to  $90^\circ$ .) Select a second triangle and identify the pair of complementary angles. Is there a set of complementary angles in every right triangle? Explain your reasoning.

**Georgia Department of Education**  
Georgia Standards of Excellence Framework  
*GSE Geometry • Unit 3*

2. Use the two triangles you chose in *Item 2* to complete the table below. What relationships among the values do you notice? Do these relationships hold true for all pairs complementary angles in right triangles? Explain your reasoning.

triangle # and angle	triangle #	$\theta$	$\sin(\theta)$	$\cos(\theta)$
1 – smaller angle	1			
1 – larger angle	1			
2 – smaller angle	2			
2 – larger angle	2			

Summarize the relationships you stated in *Item 3*.

- a. If  $\theta$  is the degree measure of an acute angle in a right triangle, what is the measure of its complement?
- b. State the relationships from *Item 3* as identity equations involving sines, cosines of  $\theta$  and the measure of its complement. Use the expression from *part a*.



## Find That Side or Angle

### Standards Addressed in this Unit

**MGSE9-12.G.SRT.8** Use trigonometric ratios and the Pythagorean Theorem to solve right triangles in applied problems.

### Standards of Mathematical Practice

**1. Make sense of problems and persevere in solving them** by requiring students to interpret and make meaning of a problem and find a logical starting point, and to monitor their progress and change their approach to solving the problem, if necessary.

**4. Model with mathematics** by expecting students to apply the mathematics concepts they know in order to solve problems arising in everyday situations, and reflect on whether the results are sensible for the given scenario.

**5. Use appropriate tools strategically** by expecting students to consider available tools when solving a mathematical problem. These tools might include pencil and paper, concrete models, a ruler, a protractor, a compass, a calculator, software, etc.

### Common Student Misconceptions

1. Some students believe that right triangles must be oriented a particular way.
2. Some students do not realize that opposite and adjacent sides need to be identified with reference to a particular acute angle in a right triangle.
3. Some students believe that the trigonometric ratios defined in this cluster apply to all triangles, but they are only defined for acute angles in right triangles.

### Supplies needed

Calculators for finding values of sine and cosine and their inverses

### Comments

*Through the task, students use trigonometric ratios to find the lengths of sides, or measures of acute angles, in right triangles as a means of solving applied problems, that is, problems with real-world contexts. At first, students use the exact values of trigonometric ratios for angle measures from the special right triangles,  $30^\circ$ -  $60^\circ$ -  $90^\circ$  and  $45^\circ$ -  $45^\circ$ -  $90^\circ$ , in finding unknown side lengths (Items 1 – 2). Then students are introduced to the approximate values of  $\sin(\theta)$  and  $\cos(\theta)$  available on their calculators and use these to solve problems that involve finding side lengths (Items 3 – 4). Next students are given two side lengths and asked to find angle measures. In the first such problem (Item 5), students are guided to the use of the inverse trig function keys as a way to find the input that gives a particular ratio. This item also requires students to use the Pythagorean Theorem to find the length of the third side of the triangle. The remaining problems provide less guidance and give students additional practice in applying trigonometric ratios to solve problems.*

1. A ladder is leaning against the outside wall of a building. The figure at the right shows the view from the end of the building, looking directly at the side of the ladder. The ladder is exactly 10 feet long and makes an angle of  $60^\circ$  with the ground. If the ground is level, what angle does the ladder make with the side of the building? How far up the building does the ladder reach (give an exact value and then approximate to the nearest inch)? Hint: Use a known trigonometric ratio in solving this problem.]

Solution(s):

Since the ground is level, the building makes a right angle with the ground, and we have a right triangle with one leg up the side of the building, one leg along the ground, and the ladder as hypotenuse, as shown in the figure. The angle with the ground is  $60^\circ$ , so the angle with the side of the building is  $30^\circ$ .

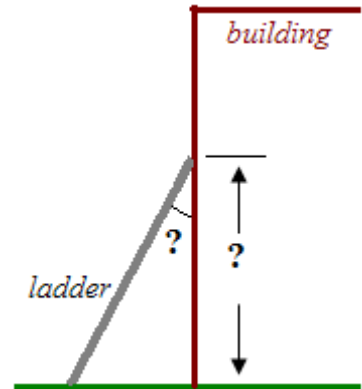

Let  $h$  equal the ladder reaches up the side of the building.

$$\text{Then, } \frac{h}{10 \text{ ft}} = \sin(60^\circ) .$$

$$\text{Hence, } h = (10 \text{ ft}) \cdot \sin(60^\circ) = (10 \text{ ft}) \cdot \frac{\sqrt{3}}{2} = 5\sqrt{3} \text{ ft exactly}$$

$$5\sqrt{3} \text{ ft} \approx 8.660254038 \text{ ft so } h =$$

$$(8.660254038 \text{ ft}) \left( 12 \frac{\text{in}}{\text{ft}} \right) \approx 104 \text{ in approximately}$$

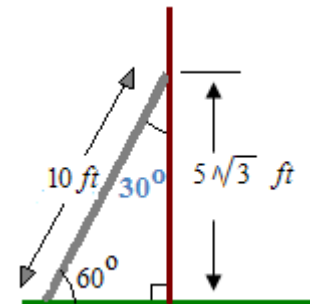

2. The main character in a play is delivering a monologue, and the lighting technician needs to shine a spotlight onto the actor's face. The light being directed is attached to a ceiling that is 10 feet above the actor's face. When the spotlight is positioned so that it shines on the actor's face, the light beam makes an angle of  $20^\circ$  with a vertical line down from the spotlight. How far is it from the spotlight to the actor's face? How much further away would the actor be if the spotlight beam made an angle of  $32^\circ$  with the vertical?

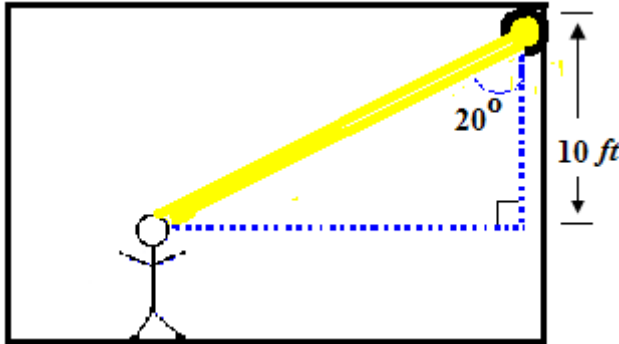

Comment(s):

*Students are limited to sine and cosine functions, so the equation to be solved here requires that the unknown be in the denominator. Students should be prompted to use what they know about solving rational equations, that is, to multiply by the LCD first to eliminate the rational expressions.*

*Teachers can encourage students to leave the trigonometric expression in the equation until they are ready to calculate, as shown in the solution, so that they use all the accuracy of the calculator.*

Solution(s):

*We are given the length of the side adjacent to the  $20^\circ$  angle and asked to find the length of the hypotenuse. The cosine ratio is adjacent/hypotenuse.*

*Let  $x$  be the unknown distance from the spotlight to the actor's face. Then,*

$$\cos(20^\circ) = \frac{10 \text{ ft}}{x} \rightarrow x \cdot \cos(20^\circ) = 10 \text{ ft} \rightarrow x = \frac{10 \text{ ft}}{\cos(20^\circ)} \approx 10.64 \text{ ft}$$

*For an angle of  $32^\circ$ , we have:*

$$\cos(32^\circ) = \frac{10 \text{ ft}}{x} \rightarrow x \cdot \cos(32^\circ) = 10 \text{ ft} \rightarrow x = \frac{10 \text{ ft}}{\cos(32^\circ)} \approx 11.79 \text{ ft}$$

*So, the actor's face is approximately  $11.79 - 10.64 = 1.15$  feet further away with the larger angle.*

3. A forest ranger is on a fire lookout tower in a national forest. His observation position is 214.7 feet above the ground when he spots an illegal campfire. The angle of depression of the line of sight to the campfire is  $12^\circ$ . (See the figure below.)

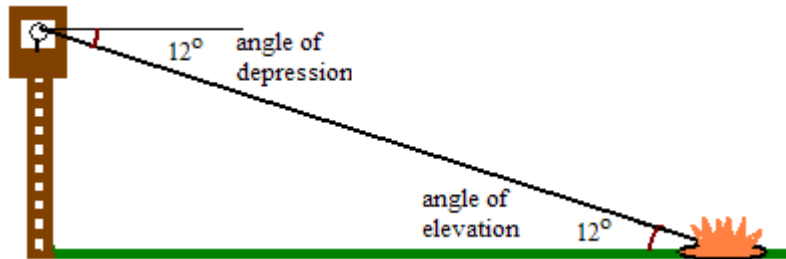

Note that an angle of depression is measured down from the horizontal because, to look down at something, you need to lower, or depress, the line of sight from the horizontal. We observe that the line of sight makes a transversal across two horizontal lines, one at the level of the viewer (such as the level of the forest ranger) and one at the level of the object being viewed (such as the level of the campfire). Thus, the angle of depression looking down from the fire lookout tower to the campfire, and the angle of elevation is the angle looking up from the campfire to the tower. The type of angle that is used in describing a situation depends on the location of the observer.

The angle of depression is equal to the corresponding angle of depression. Why?

Comment(s):

*This item introduces “angle of elevation” and “angle of depression” to give students exposure to these terms that occur frequently in applications of right triangle trigonometry. Understanding these terms is associated with having a clear understanding of the verbs “elevate” and “depress”. With this understanding, it also helps to know the relationship between the two, so this part makes a brief digression to check that students understand the relationship of the two angles.*

Solution(s):

*Since the line of sight makes a transversal across two parallel lines (any two horizontal lines are parallel), these angles are alternate interior angles and must be equal.*

*Alternately, we observe that these angles have the same complement, and, hence, must be equal.*

4. An airport is tracking the path of one of its incoming flights. If the distance to the plane is 850 ft. (from the ground) and the altitude of the plane is 400 ft.

- a. What is the sine of the angle of elevation from the ground at the airport to the plane (see figure at the right)?

Solution(s):

Let  $\theta$  denote the angle of elevation.

$$\sin(\theta) = \frac{\text{opp}}{\text{hyp}} = \frac{400 \text{ ft}}{850 \text{ ft}} = \frac{8}{17}$$

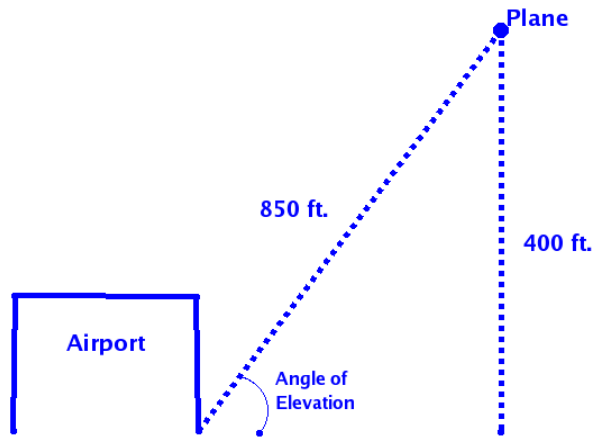

- b. What is the cosine of the angle of elevation?

Solution(s):

We continue to let  $\theta$  denote the angle of elevation.

$\cos(\theta) = \frac{\text{adj}}{\text{hyp}}$  so we need the length of the adjacent side to find these values. Let  $x$

= the length of the adjacent side. By the Pythagorean Theorem,

$$(400)^2 + x^2 = (850)^2 \rightarrow x^2 = 562500 \rightarrow x = 750, \text{ since } x \text{ is a length. Then,}$$

$$\cos(\theta) = \frac{750}{850} = \frac{15}{17}$$

- c. Now, use your calculator to find the measure of the angle itself. Pressing “2<sup>nd</sup>” followed by one of the trigonometric function keys finds the degree measure corresponding to a given ratio. Press 2<sup>nd</sup>, SIN, followed by the sine of the angle from part a. What value do you get?

Comment(s):

The remaining parts of this item introduce students to using inverse trig function keys to find angles given their sines or cosines. This is all that students will learn about inverse trig functions at this point.

Solution(s):

$$\sin^{-1}\left(\frac{8}{17}\right) = 28.07248694$$

- d. Press 2<sup>nd</sup>, COS, followed by the cosine of the angle from *part b* and. What value do you get?

Solution(s):

$$\cos^{-1}\left(\frac{15}{17}\right) = 28.07248694$$

Did you notice that, for each of the calculations in *parts c-d*, the name of the trigonometric ratio is written with an exponent of -1? These expressions are used to indicate that we are starting with a trigonometric ratio (sine and cosine,) and going backwards to find the angle that gives that ratio. You'll learn more about this notation later. For now, just remember that it signals that you are going backwards from a ratio to the angle that gives the ratio.

- e. Why did you get the same answer each time?

Solution(s):

*We got the same answer each time because each time we gave the calculator a trigonometric ratio for the angle of elevation and the calculator gave us the angle. Since the ratios all come from the same angle, we got the same answer each time.*

- f. To the nearest hundredth of a degree, what is the measure of the angle of elevation?

Solution(s):

*The angle of elevation from the ground at the airport to the plane = 28.07°*

- g. Look back at Table 1 from the *Create Your Own Triangles Learning Task*. Is your answer to *part g* consistent with the table entries for sine and cosine?

Solution(s):

*Yes, 28.07° is between 25° and 30°. Looking at the approximate values of the trigonometric ratios in Table 1, each ratio for our answer of 28.07° is between the ratios listed for 25° and 30°.*



5. The top of a billboard is 40 feet above the ground. What is the angle of elevation of the sun when the billboard casts a 30-foot shadow on level ground?

Comment(s):

*This item requires that students draw their own figures. They will need to apply knowledge of angle of elevation gained from doing Item 2 and use an inverse trig ratio to find the angle, as they just learned in Item 5. As students are likely to realize, the triangle is a 3-4-5 right triangle, so the length of the hypotenuse is 50 feet. Thus, students may easily use any one of the inverse trigonometric functions,  $\sin^{-1}$  or  $\cos^{-1}$ .*

Solution(s):

*The angle of elevation of the sun =  $53.13^\circ$*

*The triangle in question is shown in the figure at the right.*

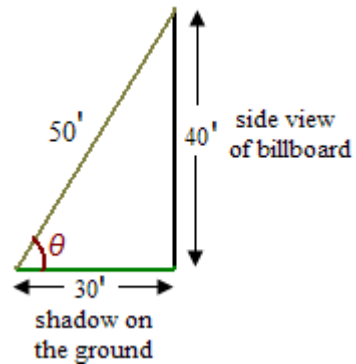

$$\sin(\theta) = \frac{40}{50} = \frac{4}{5} \quad \rightarrow \quad \sin^{-1}\left(\frac{4}{5}\right) \approx 53.13^\circ$$

$$\cos(\theta) = \frac{30}{50} = \frac{3}{5} \quad \rightarrow \quad \cos^{-1}\left(\frac{3}{5}\right) \approx 53.13^\circ$$

6. An observer in a lighthouse sees a sailboat out at sea. The angle of depression from the observer to the sailboat is  $6^\circ$ . The base of the lighthouse is 50 feet above sea level and the observer's viewing level is 84 feet above the base. (See the figure at the right, which is not to scale.)

Comment(s):

*To be successful in solving the parts of this item, students must realize that the two legs of the right triangles to be used lie on the horizontal line at sea level and the vertical line through the observer's position. Figures provided with the solutions show these right triangles.*

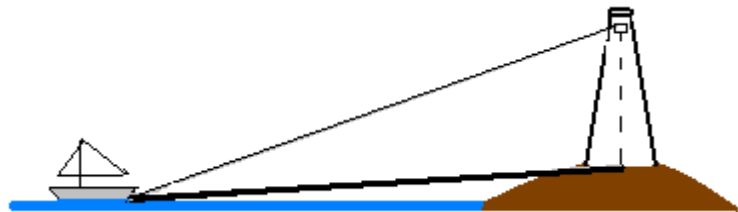

What's the distance from the sailboat to the observer?

*Solution(s):*

*If we extend the line from the observer to the base of the light house down to sea level, we have a right triangle containing a  $6^\circ$  angle. The side opposite the  $6^\circ$  angle has length 134 feet and the length,  $x$ , of the hypotenuse is the distance from the sailboat to the observer.*

$$\sin(6^\circ) = \frac{134'}{x}$$
$$x = \frac{134'}{\sin(6^\circ)} \approx 1282'$$

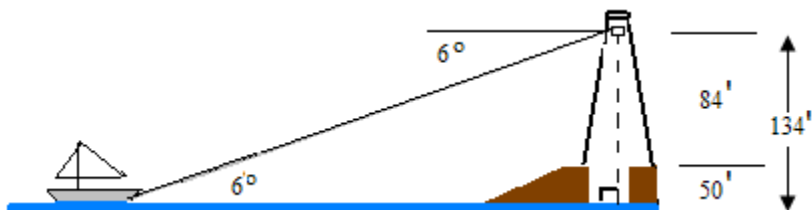

*Thus, the (straight line) distance from the sailboat to the observer is approximately 1282 feet.*

*Final teachers' notes related to this task:*

*In addition to textbook sources you have available, many other good applications problems are available on the Internet, although finding them requires some searching, and bypassing the many commercial sites selling mathematics help. The following problems were found searching for “right triangle trigonometry applications problems.” They provide other scenarios related to solving triangles.*

*Example 4 at the bottom of the page at [http://www.intmath.com/Trigonometric-functions/4\\_Right-triangle-applications.php](http://www.intmath.com/Trigonometric-functions/4_Right-triangle-applications.php)*

*Problem 2 at <http://www.themathpage.com/atrig/solve-right-triangles.htm>*

*Exercises 9 – 11 at <http://www.ulm.edu/~seeber/114/Rt.%20Tri.%20Prob..doc> Note that many interesting looking on-line exercises are similar to Exercise 12 on this page; students need to write a system of equations to solve such problems. These make great challenge problems for advanced students*

## Find That Side or Angle

### Standards Addressed in this Task

**MGSE9-12.G.SRT.8** Use trigonometric ratios and the Pythagorean Theorem to solve right triangles in applied problems.

### Standards of Mathematical Practice

**1. Make sense of problems and persevere in solving them** by requiring students to interpret and make meaning of a problem and find a logical starting point, and to monitor their progress and change their approach to solving the problem, if necessary.

**4. Model with mathematics** by expecting students to apply the mathematics concepts they know in order to solve problems arising in everyday situations, and reflect on whether the results are sensible for the given scenario.

**5. Use appropriate tools strategically** by expecting students to consider available tools when solving a mathematical problem. These tools might include pencil and paper, concrete models, a ruler, a protractor, a compass, a calculator, software, etc.

### Supplies needed

Calculators for finding values of sine and cosine and their inverses

1. A ladder is leaning against the outside wall of a building. The figure at the right shows the view from the end of the building, looking directly at the side of the ladder. The ladder is exactly 10 feet long and makes an angle of  $60^\circ$  with the ground. If the ground is level, what angle does the ladder make with the side of the building? How far up the building does the ladder reach (give an exact value and then approximate to the nearest inch)? Hint: Use a known trigonometric ratio in solving this problem.

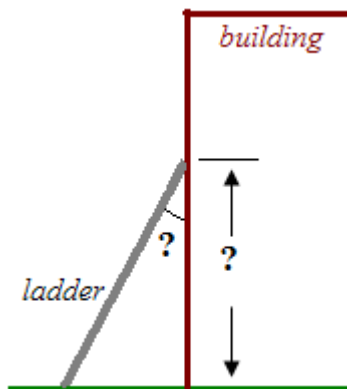

The first problem in this task involves trigonometric ratios in special right triangles, where the values of all the ratios are known exactly. However, there are many applications involving other size angles. Graphing calculators include keys to give values for the sine and cosine functions with very accurate approximations for all trigonometric ratios of degree measures greater than  $0^\circ$  and less than  $90^\circ$ . You should use calculator values for trigonometric functions, as needed, for the remainder of this task.

In higher mathematics, it is standard to measure angles in radians. The issue concerns you now because you need to make sure that your calculator is in **degree mode** (and not radian mode) before you use it for finding values of trigonometric ratios. If you are using any of the IT-83/84 calculators, press the MODE button, then use the arrow keys to highlight “Degree” and press enter. The graphic at the right shows how the screen will look when you have selected degree mode. To check that you have the calculator set correctly, check by pressing the TAN key, 45, and then ENTER. The answer should be 1. If you are using any other type of calculator, find out how to set it in degree mode, do so, and check as suggested above. Once you are sure that your calculator is in degree mode, you are ready to proceed to the remaining items of the question.

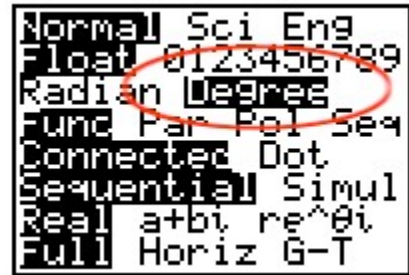

- The main character in a play is delivering a monologue, and the lighting technician needs to shine a spotlight onto the actor's face. The light being directed is attached to a ceiling that is 10 feet above the actor's face. When the spotlight is positioned so that it shines on the actor's face, the light beam makes an angle of  $20^\circ$  with a vertical line down from the spotlight. How far is it from the spotlight to the actor's face? How much further away would the actor be if the spotlight beam made an angle of  $32^\circ$  with the vertical?

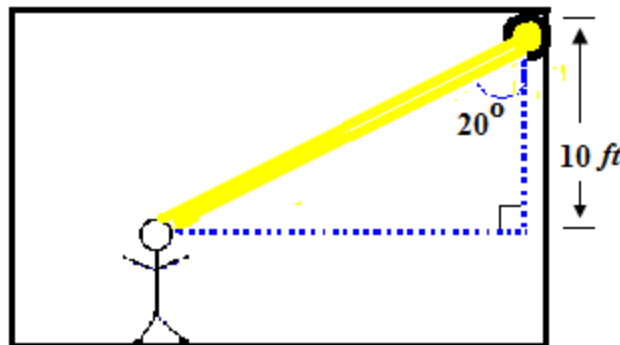

3. A forest ranger is on a fire lookout tower in a national forest. His observation position is 214.7 feet above the ground when he spots an illegal campfire. The angle of depression of the line of site to the campfire is  $12^\circ$ . (See the figure below.)

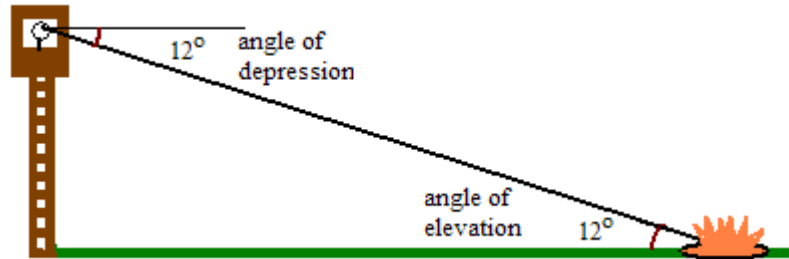

Note that an angle of depression is measured down from the horizontal; in order to look down at something, you need to lower, or depress, the line of sight from the horizontal. We observe that the line of sight makes a transversal across two horizontal lines, one at the level of the viewer (such as the level of the forest ranger), and one at the level of the object being viewed (such as the level of the campfire). Thus, the angle of depression looking down from the fire lookout tower to the campfire, and the angle of elevation is the angle looking up from the campfire to the tower. The type of angle that is used in describing a situation depends on the location of the observer.

The angle of depression is equal to the corresponding angle of elevation. Why?

4. An airport is tracking the path of one of its incoming flights. If the distance to the plane is 850 ft. (from the ground) and the altitude of the plane is 400 ft, then

a. What is the sine of the angle of elevation from the ground at the airport to the plane (see figure at the right)?

b. What is the cosine of the angle of elevation?

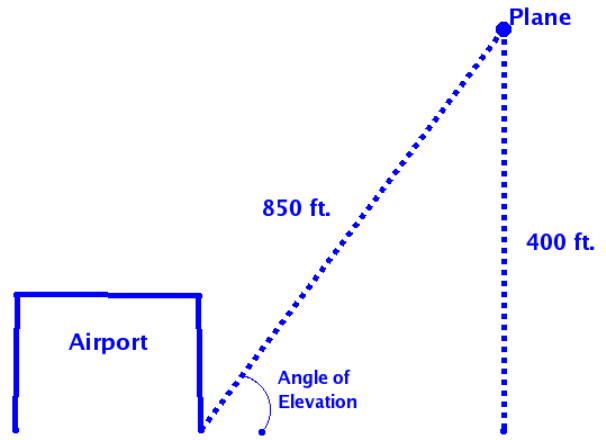

c. Now, use your calculator to find the measure of the angle itself. Pressing “2<sup>nd</sup>” followed by one of the trigonometric function keys finds the degree measure corresponding to a given ratio. Press 2<sup>nd</sup>, SIN, followed by the sine of the angle from *part a*. What value do you get?

d. Press 2<sup>nd</sup>, COS, followed by the cosine of the angle from *part b*. What value do you get?

Did you notice that, for each of the calculations in *parts c-d*, the name of the trigonometric ratio is written with an exponent of -1? These expressions are used to indicate that we are starting with a trigonometric ratio (sine and cosine,) and going backwards to find the angle that gives that ratio. You’ll learn more about this notation later. For now, just remember that it signals that you are going backwards from a ratio to the angle that gives the ratio.

e. Why did you get the same answer each time?

f. To the nearest hundredth of a degree, what is the measure of the angle of elevation?

g. Look back at Table 1 from the *Create Your Own Triangles Learning Task*. Is your answer to *part g* consistent with the table entries for sine and cosine?



**Georgia Department of Education**  
Georgia Standards of Excellence Framework  
*GSE Geometry • Unit 3*

5. The top of a billboard is 40 feet above the ground. What is the angle of elevation of the sun when the billboard casts a 30-foot shadow on level ground?

6. An observer in a lighthouse sees a sailboat out at sea. The angle of depression from the observer to the sailboat is  $6^\circ$ . The base of the lighthouse is 50 feet above sea level and the observer's viewing level is 84 feet above the base. (See the figure at the right, which is not to scale.)

What is the distance from the sailboat to the observer?

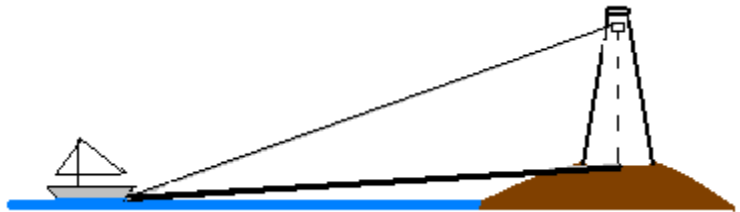

## **Formative Assessment Lesson: Right Triangles in Your Environment**

*Source: Georgia Mathematics Design Collaborative*

This lesson is intended to help you assess how well students are able to:

- Use trigonometric ratios to find sides and angles of right triangles
- Diagram and solve applied problems

### **STANDARDS ADDRESSED IN THIS TASK:**

**MGSE9-12.G.SRT.8** Use trigonometric ratios and the Pythagorean Theorem to solve right triangles in applied problems.

### **STANDARDS FOR MATHEMATICAL PRACTICE:**

This lesson uses all of the practices with emphasis on:

1. Make sense of problems and persevere in solving them
3. Construct viable arguments and critique the reasoning of others
4. Model with mathematics
6. Attend to precision

### **TASK DESCRIPTION, DEVELOPMENT AND DISCUSSION:**

Tasks and lessons from the Georgia Mathematics Design Collaborative are specifically designed to help teachers effectively formatively assess their students. The way the tasks and lessons are designed gives the teacher a clear understanding of what the students are able to do and not do. Within the lesson, teachers will find suggestions and question prompts that will help guide students towards understanding.

The task, *Right Triangles in Your Environment*, is a Formative Assessment Lesson (FAL) that can be found at: <http://ecgpsmathematics9-10.wikispaces.com/Georgia+Mathematics+Design+Collaborative+Formative+Assessment+Lessons>

## **Culminating Task: Clyde's Construction Crew**

*This is a formative assessment lesson; the optimal time to use this is after introducing application of right triangle trigonometry.*

### **Mathematical Goals**

This lesson is intended to help the teacher assess how well students are able to set-up trigonometric application problems involving right triangles.

### **Standards Addressed in the Unit**

**MGSE9-12.G.SRT.6** Understand that by similarity, side ratios in right triangles are properties of the angles in the triangle, leading to definitions of trigonometric ratios for acute angles.

**MGSE9-12.G.SRT.7** Explain and use the relationship between the sine and cosine of complementary angles.

**MGSE9-12.G.SRT.8** Use trigonometric ratios and the Pythagorean Theorem to solve right triangles in applied problems.

### **Standards for Mathematical Practice**

- 1. Make sense of problems and persevere in solving them** by requiring students to interpret and make meaning of a problem and find a logical starting point, and to monitor their progress and change their approach to solving the problem, if necessary.
- 2. Reason abstractly and quantitatively** by requiring students to make sense of quantities and their relationships to one another in problem situations.
- 3. Construct viable arguments and critique the reasoning of others** by engaging students on discussion of why they agree or disagree with responses, decide whether they make sense, and ask useful questions to clarify or improve the arguments.
- 4. Model with mathematics** by expecting students to apply the mathematics concepts they know in order to solve problems arising in everyday situations, and reflect on whether the results are sensible for the given scenario.
- 5. Use appropriate tools strategically** by expecting students to consider available tools when solving a mathematical problem. These tools might include pencil and paper, concrete models, a ruler, a protractor, a compass, a calculator, software, etc.
- 6. Attend to precision** by requiring students to calculate efficiently and accurately; and to communicate precisely with others by using clear mathematical language to discuss their reasoning.
- 7. Look for and make use of structure** by expecting students to apply rules, look for patterns and analyze structure.

**8. Look for and express regularity in repeated reasoning** by expecting students to understand broader applications and look for structure and general methods in similar situations.

**Materials required**

Pretest/Posttest, Scientific Calculator, Cards (below), which should be cut and separated

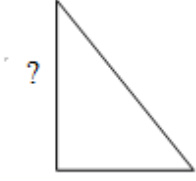
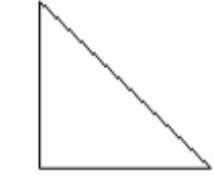
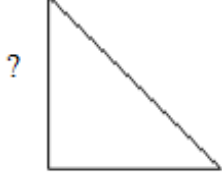
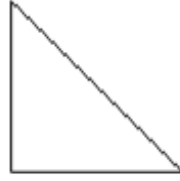
<p>Richard is using a clinometer to determine the height of a radio tower. He places the clinometers 80.8 meters from the base of the tower and measures the angle of elevation to be 76 degrees. Find the height of the tower.</p>	
<p>James is using a clinometer to determine the horizontal distance between his on-site office and David's office. He stands at his office window and calculates the angle of depression to David's office window. James is at an elevation of 80 feet, and David's office is at an elevation of 36 feet. He measures a 25 degree angle of depression. Find the horizontal distance between the offices.</p>	
<p>Richard is using a clinometer to measure the height of the observation deck being used to oversee the projects. He stands on the deck and finds the angle of depression to the top of a building that is 100 feet tall. The building is 466.5 feet from the deck. Richard measures a 42 degrees angle of depression. Find the height of the observation deck.</p>	
<p>James lives in an apartment building near the construction site and can see a skyscraper from his living room window. He would like to know how far his apartment building is from the skyscraper. He uses a clinometer to measure the angle of elevation from his apartment to the top of the skyscraper. The angle of elevation is 38 degrees. He knows that the skyscraper is 630 feet tall and the height of his living room window is 200 feet. Find the distance between James' apartment and the skyscraper to the nearest foot.</p>	

**Georgia Department of Education**  
 Georgia Standards of Excellence Framework  
*GSE Geometry • Unit 3*

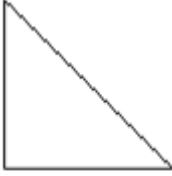
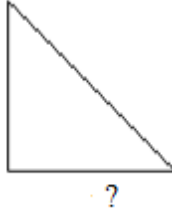
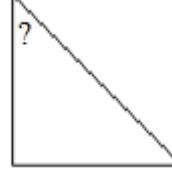
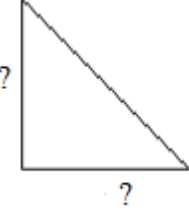
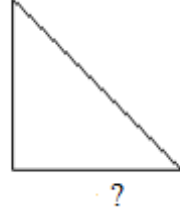
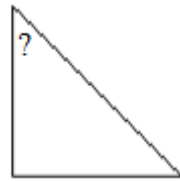
<p>A ladder is leaning against one of the buildings on the construction site at a 50 degree angle. The ladder is 15 feet long. How far up the side of the building does the ladder reach?</p>	
<p>Suppose that the length of the step is 12 inches and the measure of angle A is 60 degrees. Find the rise and run of the step.</p>	
<p>A ramp on one of the buildings rises 5 feet to the top of a wall. The cosine of the angle between the ground and the ramp is 0.866. What is the sine of the angle the ramp forms with the wall?</p>	
<p>The road to the construction site has an angle to the horizontal of 3 degrees. For every feet of road, how many feet does the road ascend?</p>	
<p>A 10-foot ladder is placed against a wall forming a 40 degree angle with the ground. Find the distance from the ladder to the wall.</p>	
<p>In one of the offices, a 2-foot brace holds up a bookshelf on a wall. The bookshelf is 1-foot wide. What is the measure of the angle between the brace and the wall?</p>	

A 14 foot tree on the site makes a 20-foot shadow on the ground. What is the angle between a ray of light and the shadow?



### Before the lesson

Assessment task: (20 minutes)

Students should do this task in class or for homework a day or more before the formative assessment lesson.

### Pretest

Directions:

Read through the questions and try to answer them as carefully as you can.

Do not worry too much if you cannot understand and do everything.

I will teach a lesson with a task like this later in the week..

By the end of that lesson your goal is to answer the questions with confidence.

***Make sure that all triangle diagrams are shown.***

1. A road ascends a hill at an angle of 4 degrees. For every 1000 feet of road, how many feet does the road ascend?
2. A 12-foot slide is attached to a swing set. The slide makes a 65 degree angle with the swing set. Estimate the height of the top of the slide.
3. Michelle's house is 22 miles due north of Jan's house and northeast of Richard's house. Richard's house is due west of Jan's house. How far is it from Michelle's house to Richard's house?
4. When a space shuttle returns from a mission, the angle of its descent to the ground from the final 10,000 feet above the ground is between 17 degrees and 19 degrees horizontal. Determine the minimum and maximum horizontal distance between the landing site and where the descent begins.
5. With its radar, an aircraft spots another aircraft 8000 feet away at a 12 degree angle of depression. Determine the vertical distance and horizontal distance between the two aircraft.

6. Suzie is using a clinometer to determine the height of a building. She places the clinometers 50 feet from the base of the building and measures the angle of elevation to be 72 degrees. Draw a diagram that models this situation and find the distance from the clinometer to the top of the building.

*Assessing students' responses*

*Answers to Pretest:*

1. About 6.976 feet
2. Around 5 feet
3. Around 28
4. Minimum about 29.042 feet, and maximum around 32,709 feet
5. Vertical distance around 1663 feet, while the horizontal distance is about 7825 feet
6. Around 81 feet

*Collect students' responses to the task. Make some notes on what their work reveals about their current levels of understanding. The purpose of doing this is to forewarn you of issues that will arise during the lesson itself, so that you may prepare carefully.*

*Do not score students' work. Research suggests this will be counterproductive, as it encourages students to compare their scores, and distracts their attention from what they can do to improve their mathematics.*

*Instead, help students to make further progress by summarizing their difficulties as a series of questions. Some suggestions for these are given on the next page. These have been drawn from common difficulties observed in trials of this lesson unit.*

*Suggestion: Write a list of your own questions, based on students' work, using the ideas that follow. You may choose to write questions on each student's work. If you do not have time to do this, just select a few questions that will be of help to the majority of students. These can be written on the board at the end of the lesson.*

*Common issues:*

*Suggested questions and prompts:*

<i>Student has difficulty using their calculator for trigonometric functions.</i>	<i>Is the calculator in degree or radian mode?</i>
<i>Student use the basic function key for evaluating angles.</i>	<i>What is the correct procedure for finding the angles in a triangle using trigonometric functions?</i>
<i>Student has difficulty labeling the right triangle.</i>	<i>What is the difference between angle of elevation and depression? What type of problems asks for the hypotenuse of the triangle? What is the difference between</i>



	<i>horizontal and vertical?</i>
<i>Students confuse sine and cosine.</i>	<i>What sides of the triangle are needed for sine? For cosine? What is the difference between opposite and adjacent?</i>

**Suggested lesson outline**

**Whole class introduction (20 minutes)**

*The teacher reviews right triangle applications with the following problems. Students should be allowed to work on these with guided instruction. The teacher may ask students to set-up the problems individually and then write different results on the board. Then, the class can discuss the difference in the set-ups. Finally, the students might work with a partner to finish the problems (with the correct set-ups) before the results are discussed as a class.*

**PROBLEM 1**

*Clyde is making a mosaic design for one of the floors. He needs the triangle in the design to cover 4.25 feet. Does the triangle he has sketched in his design meet the specifications?*

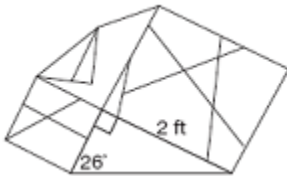

**PROBLEM 2**

*The picture below is a roof truss.*

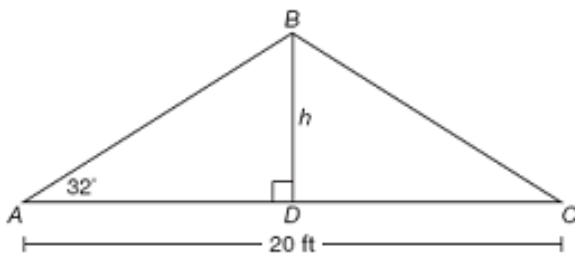

*Find the measure of angle ABD, side AD and side AB.*

**PROBLEM 3**

Kaycie leans a ladder 5m long onto the side of a house. The ladder makes an angle of 65 degrees with the ground.

a. How high on the house does the ladder reach?

*The first strategy would be to draw the situation.*

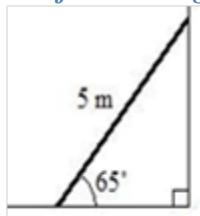

*The height of the house is opposite the angle, and we are given the hypotenuse of the triangle so we should use sine to determine the height of the house.*

Solution:

$$\sin 65^\circ = x/5 \text{ (multiply both sides by 5)}$$

$$(5)(\sin 65^\circ) = x$$

$$x \approx 4.5 \text{ m}$$

b. How far is the foot of Kaycie's ladder from the house?

*The distance from the ladder to the foot of the house is the adjacent side to the angle. Looking at our original picture and given the hypotenuse and now trying to find the adjacent, we should use the cosine ratio.*

Solution:

$$\cos 65^\circ = x/5 \text{ (multiply both sides by 5)}$$

$$(5)(\cos 65^\circ) = x$$

$$x \approx 2.1 \text{ m}$$

c. What angle does the ladder make with the wall?

*The sum of the interior angles of a triangle is 180°.*

Solution:

$$180 - (90 + 65) = 25^\circ$$

*Working in pairs OR Collaborative small-group work (30 minutes)*

*The culminating task focuses on application of the trigonometric ratios to solve problems and involves a series of problems found on a construction site.*

*Clyde and his construction crew consisting of Richard, James, and David must make repairs, take measurements, and build new structures on an existing manufacturing site. In order to do this, trigonometric functions must be used to solve the following problems. The teacher should cut the cards apart; the problems should be separated from their corresponding triangles. Students will work with their partner to match the given problem to the corresponding right triangle “set-up”. After making the matches, students are to finish labeling the triangle to match the problem. The teacher can have the students compare their results with other groups. As time permits, some pairs may complete the calculations asked for in the problems.*

**Plenary whole-class discussion (10 minutes)**

*After all of the partners finish matching their problems to the appropriate triangles, the teacher can have the pairs discuss what the most difficult type of problem to interpret was. Students’ ideas will be posted on a board or large sheet of paper with the names of the students beside their ideas.*

**Improve individual solutions to the assessment task (10 minutes)**

*Give students back their work on the pre-test along with a fresh copy of the test. Directions are as follows:*

*Work on your own for ten minutes.*

*I’m giving you your own answers, and a new sheet to work on.*

*Read through your original solution and think about what you learned during the lesson. I want you to use what you learned to improve your solutions to the pretest. Then compare your answers to see what progress you made.*

*Final Step: After everyone is finished, the teacher will collect the student work and analyze for future lessons. Hopefully, continual misconceptions will be revealed, and lessons can be tailored to clear these up for students.*

*For more formative assessment lessons and for clarification of procedures, please see*

<http://www.map.mathshell.org/materials/lessons.php>

Pretest

***Make sure that all triangle diagrams are shown.***

1. A road ascends a hill at an angle of 4 degrees. For every 1000 feet of road, how many feet does the road ascend?
2. A 12-foot slide is attached to a swing set. The slide makes a 65 degree angle with the swing set. Estimate the height of the top of the slide.
3. Michelle's house is 22 miles due north of Jan's house and northeast of Richard's house. Richard's house is due west of Jan's house. How far is it from Michelle's house to Richard's house?
4. When a space shuttle returns from a mission, the angle of its descent to the ground from the final 10,000 feet above the ground is between 17 degrees and 19 degrees horizontal. Determine the minimum and maximum horizontal distance between the landing site and where the descent begins.
5. With its radar, an aircraft spots another aircraft 8000 feet away at a 12 degree angle of depression. Determine the vertical distance and horizontal distance between the two aircraft.
6. Suzie is using a clinometer to determine the height of a building. She places the clinometer 50 feet from the base of the building and measures the angle of elevation to be 72 degrees. Draw a diagram that models this situation and find the distance from the clinometer to the top of the building.

## Culminating Task: Hypsometer Activity – Indirect Measurement

Adapted from Sandy Creek High School Math Department, Fayette County School System

### Mathematical Goal

This lesson is intended to help the teacher assess how well students are able to set-up trigonometric application problems involving right triangles.

**MGSE9-12.G.SRT.6** Understand that by similarity, side ratios in right triangles are properties of the angles in the triangle, leading to definitions of trigonometric ratios for acute angles.

**MGSE9-12.G.SRT.7** Explain and use the relationship between the sine and cosine of complementary angles.

**MGSE9-12.G.SRT.8** Use trigonometric ratios and the Pythagorean Theorem to solve right triangles in applied problems.

### Materials Required

Scientific Calculator

Pencil

Activity Sheet

Hypsometer (*directions on how to make one are listed below...once they are made they can be reused year after year or making the hypsometer can be part of the task*)

tape measure (*a long one...50 feet or more*)

### How to Make a Hypsometer

#### List of Materials:

protractor

drinking straw

string, fishing line, yarn, etc. (*about 2 feet*)

glue or tape

weight (*fishing weight, paper clip, etc*)

Step 1: Attach a straw to the protractor by laying it on the straightedge of the protractor. You can attach the straw to the protractor with glue or tape.

Step 2: Tie the weight to the string. This is used to determine perpendicularity.

Step 3: Attach the other end of the string to our protractor by inserting it through the hole found where the x and y axis meet. Tie a knot to secure it and use scissors to snip off the excess string. Allow the string to dangle freely.

Here is a picture of a hypsometer found at [www.instructables.com](http://www.instructables.com)

*Note to teacher: You can also enlarge a protractor on a copier and make it on card stock paper and laminate. Having a larger hypsometer may be easier to hold, read angle measures, and general use.*



**How do I use the hypsometer? (For this example we are using the height of the school)**

Step 1: Pick a job

**Job Title**

**Name**

1. Measurer – measures the distances from objects to looker	
2. Looker – looks through the hypsometer at the tops of objects (needs eye height measured before starting)	
3. Reader – reads angle of elevation from hypsometer	
4. Recorder – records distances and angles of elevation	

Eye height of looker (inches): \_\_\_\_\_

For all objects measured, the Measurer should measure some horizontal distance from the object for the Looker to stand. The Looker should use the hypsometer to look up to the top of the object. The Reader should read what angle the hypsometer says. The Recorder should record both pieces of data.

**Georgia Department of Education**  
 Georgia Standards of Excellence Framework  
*GSE Geometry • Unit 3*

Step 2: From the wall of the school, measure how far away you are standing. Write this down as your base length.

Step 3: Looking through the straw of the hypsometer, find the roof of the school building and look at which degree the line falls on. If you read the degree measure on the protractor at the point where the string dangles, how would you determine the angle of elevation? \_\_\_\_\_

*(Students find that the complement is the angle measurement for elevation.)*

Step 4: Use your right triangle trig knowledge to find the height of the building. Don't forget to take into consideration the height of the "looker!"

Here is an example found at [www.instructables.com](http://www.instructables.com)

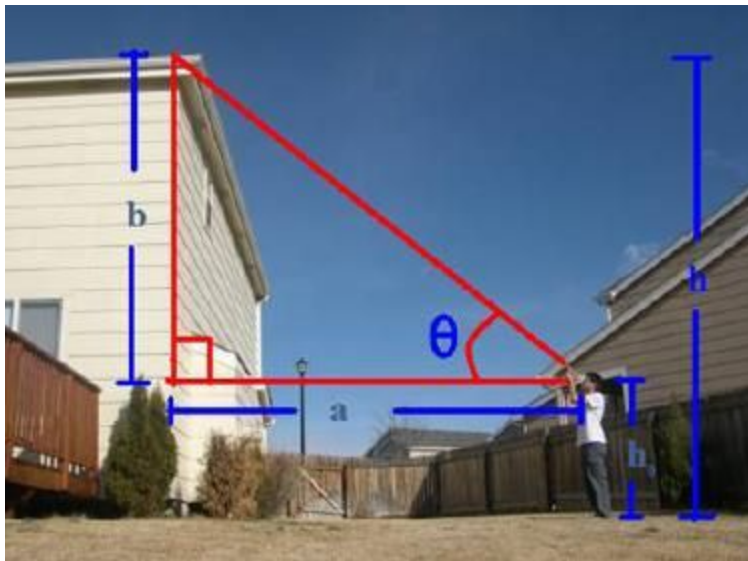

**Now let's measure some objects!**

*Pick several tall objects in and around your building. Have students go outside together to gather their data. There are four listed below, but they should certainly be changed for what you are using.*

<b>Object</b>	<b>Distance (inches)</b>	<b>Angle of Elevation (degrees)</b>
1. flag pole		
2. light post		
3. garage		
4. football goal post		



**Georgia Department of Education**  
 Georgia Standards of Excellence Framework  
*GSE Geometry • Unit 3*

**Calculations:** Find the height of each object using right triangle trigonometry. Draw diagrams and show work on back of paper (they should resemble right triangles). Solve for the height of the objects using trigonometric functions. Convert final answers to feet.

1.



2.



3.



4.

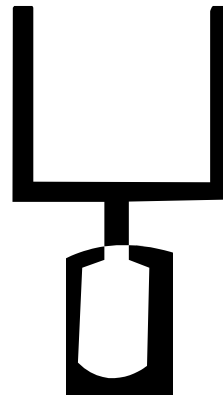

**Results: Heights in feet (divide your answer by 12)**

1. light post	3. garage
2. flag pole	4. football goal post

**Analyze and Extend**

1. Have each team write the height of each object on the board. Discuss discrepancies. Why did these discrepancies occur?
2. Determine the class estimate of the heights of each object from the gathered data. Show or explain this number.
3. Create a box and whisker plot. Discuss the mean.
4. Switch partner jobs and repeat the activity. What happens when the looker is a different height? Did you calculate the same height? Discuss why there may have been discrepancies between partners.
5. After measuring the angle of elevation, step back 10 feet and measure again. Discuss how the relationship of the distance and the angle of elevation change.
6. Research an occupation that uses trigonometry to find height.

**The following web sites and articles provide enrichment and support for this activity:**

1. [www.instructables.com](http://www.instructables.com)
2. [http://www.denisekapler.com/files/7013/5261/8526/Make\\_a\\_Hypsometer\\_3-2011.pdf](http://www.denisekapler.com/files/7013/5261/8526/Make_a_Hypsometer_3-2011.pdf)
3. [http://stargazers.gsfc.nasa.gov/pdf/activities/math\\_activities/math\\_teacher/math\\_act\\_12\\_t.pdf](http://stargazers.gsfc.nasa.gov/pdf/activities/math_activities/math_teacher/math_act_12_t.pdf)

## Culminating Task: Hypsometer Activity – Indirect Measurement

Adapted from Sandy Creek High School Math Department, Fayette County School System

### How to Make a Hypsometer

#### List of Materials:

protractor  
drinking straw  
string, fishing line, yarn, etc.  
glue or tape  
weight

Step 1: Attach a straw to the protractor by laying it on the straightedge of the protractor. You can attach the straw to the protractor with glue or tape.

Step 2: Tie the weight to the string. This is used to determine perpendicularity.

Step 3: Attach the other end of the string to our protractor by inserting it through the hole found where the x and y axis meet. Tie a knot to secure it and use scissors to snip off the excess string. Allow the string to dangle freely.

Here is a picture of a hypsometer found at [www.instructables.com](http://www.instructables.com)



**How do I use the hypsometer? (For this example we are using the height of the school)**

Step 1: Pick a job

<b>Job Title</b>	<b>Name</b>
1. Measurer – measures the distances from objects to looker	
2. Looker – looks through the hypsometer at the tops of objects (needs eye height measured before starting)	
3. Reader – reads angle of elevation from hypsometer	
4. Recorder – records distances and angles of elevation	

Eye height of looker (inches): \_\_\_\_\_

For all objects measured, the Measurer should measure some horizontal distance from the object for the Looker to stand. The Looker should use the hypsometer to look up to the top of the object. The Reader should read what angle the hypsometer says. The Recorder should record both pieces of data.

Step 2: From the wall of the school, measure how far away you are standing. Write this down as your base length.

Step 3: Looking through the straw of the hypsometer, find the roof of the school building and look at which degree the line falls on. If you read the degree measure on the protractor at the point where the string dangles, how would you determine the angle of elevation? \_\_\_\_\_

Step 4: Use your right triangle trig knowledge to find the height of the building. Don't forget to take into consideration the height of the "looker!"

Here is an example found at [www.instructables.com](http://www.instructables.com)

Georgia Department of Education  
Georgia Standards of Excellence Framework  
GSE Geometry • Unit 3

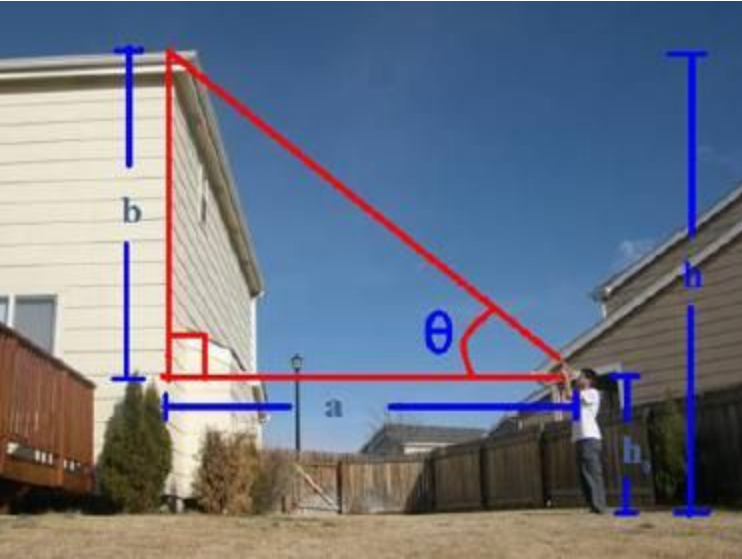

Now let's measure some objects!

<u>Object</u>	<u>Distance (inches)</u>	<u>Angle of Elevation (degrees)</u>
1. flag pole		
2. light post		
3. garage		
4. football goal post		

**Georgia Department of Education**  
 Georgia Standards of Excellence Framework  
*GSE Geometry • Unit 3*

**Calculations:** Find the height of each object using right triangle trigonometry. Draw diagrams and show work on back of paper (they should resemble right triangles). Solve for the height of the objects using trigonometric functions. Convert final answers to feet.

1.



2.



3.



4.

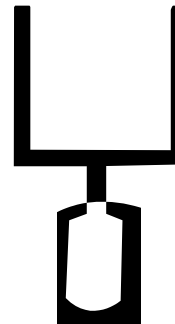

**Results: Heights in feet (divide your answer by 12)**

1. light post	3. garage
2. flag pole	4. football goal post

**Analyze and Extend**

1. Have each team write the height of each object on the board. Discuss discrepancies. Why did these discrepancies occur?
2. Determine the class estimate of the heights of each object from the gathered data. Show or explain this number.
3. Create a box and whisker plot. Discuss the mean.
4. Switch partner jobs and repeat the activity. What happens when the looker is a different height? Did you calculate the same height? Discuss why there may have been discrepancies between partners.
5. After measuring the angle of elevation, step back 10 feet and measure again. Discuss how the relationship of the distance and the angle of elevation change.
6. Research an occupation that uses trigonometry to find height.

**The following web sites and articles provide enrichment and support for this activity:**

1. [www.instructables.com](http://www.instructables.com)
2. [http://www.denisekapler.com/files/7013/5261/8526/Make\\_a\\_Hypsometer\\_3-2011.pdf](http://www.denisekapler.com/files/7013/5261/8526/Make_a_Hypsometer_3-2011.pdf)
3. [http://stargazers.gsfc.nasa.gov/pdf/activities/math\\_activities/math\\_teacher/math\\_act\\_12\\_t.pdf](http://stargazers.gsfc.nasa.gov/pdf/activities/math_activities/math_teacher/math_act_12_t.pdf)