



Georgia Standards of Excellence Curriculum Frameworks

Mathematics

GSE Geometry

Unit 2: Similarity, Congruence, and Proofs



Richard Woods, Georgia's School Superintendent
"Educating Georgia's Future"

Unit 2
Similarity, Congruence, and Proofs

Table of Contents

OVERVIEW	3
STANDARDS ADDRESSED IN THIS UNIT	4
KEY STANDARDS	4
STANDARDS FOR MATHEMATICAL PRACTICE	6
ENDURING UNDERSTANDINGS	6
ESSENTIAL QUESTIONS	7
CONCEPTS/SKILLS TO MAINTAIN	8
SELECTED TERMS AND SYMBOLS	9
EVIDENCE OF LEARNING	12
FORMATIVE ASSESSMENT LESSONS (FAL)	13
SPOTLIGHT TASKS	13
TASKS	14
Introductory Activity (Spotlight Task)	16
Introducing Congruence (Spotlight Task)	22
Formative Assessment Lesson: Analyzing Congruency Proofs	28
Formalizing Triangle Congruence Theorems	30
Triangle Proofs	39
Lunch Lines	50
Triangle Proportionality Theorem	63
Challenges from Ancient Greece	77
Constructing Parallel and Perpendicular Lines	93
Constructions Inscribed in a Circle	99
Centers of Triangles	108
Constructing with Diagonals	125
Formative Assessment Lesson: Evaluating Statements about Length & Area	141
Formative Assessment Lesson: Floor Pattern	143
Dilations in the Coordinate Plane	145
Similar Triangles	156
Shadow Math	161
Proving Similar Triangles	166
Formative Assessment Lesson: Hopewell Geometry	174
Pythagorean Theorem using Triangle Similarity	176
Formative Assessment Lesson: Solving Geometry Problems - Floodlights	176
Culminating Task: Geometry Gardens	186

OVERVIEW

In this unit students will:

- verify experimentally with dilations in the coordinate plane
- use the idea of dilation transformations to develop the definition of similarity
- determine whether two figures are similar
- use the properties of similarity transformations to develop the criteria for proving similar triangles
- use AA, SAS, SSS similarity theorems to prove triangles are similar
- use triangle similarity to prove other theorems about triangles
- using similarity theorems to prove that two triangles are congruent
- prove geometric figures, other than triangles, are similar and/or congruent
- use descriptions of rigid motion and transformed geometric figures to predict the effects rigid motion has on figures in the coordinate plane
- know that rigid transformations preserve size and shape or distance and angle; use this fact to connect the idea of congruency and develop the definition of congruent
- use the definition of congruence, based on rigid motion, to show two triangles are congruent if and only if their corresponding sides and corresponding angles are congruent
- use the definition of congruence, based on rigid motion, to develop and explain the triangle congruence criteria; ASA, SSS, and SAS
- prove theorems pertaining to lines and angles
- prove theorems pertaining to triangles
- prove theorems pertaining to parallelograms
- make formal geometric constructions with a variety of tools and methods
- construct an equilateral triangle, a square, and a regular hexagon inscribed in a circle

Geometry connects algebra and geometry, resulting in powerful methods of analysis and problem solving. This unit of Geometry involves similarity, congruence, and proofs. Students will understand similarity in terms of similarity transformations, prove theorems involving similarity, understand congruence in terms of rigid motions, prove geometric theorems, and make geometric constructions. During high school, students begin to formalize their geometry experiences from elementary and middle school, using more precise definitions and developing careful proofs.

The concepts of congruence, similarity, and symmetry can be understood from the perspective of geometric transformation. During the middle grades, through experiences drawing triangles from given conditions, students notice ways to specify enough measures in a triangle to ensure that all triangles drawn with those measures are congruent. Once these triangle congruence criteria (ASA, SAS, and SSS) are established using rigid motions, they can be used to prove theorems about triangles, quadrilaterals, and other geometric figures. Encourage multiple ways of writing proofs, such as in narrative paragraphs, using flow diagrams, in two-column format, and using diagrams without words. Students should be encouraged to focus on the validity of the underlying reasoning while exploring a variety of formats for expressing that reasoning.

Similarity transformations (rigid motions followed by dilations) define similarity in the same way that rigid motions define congruence, thereby formalizing the similarity ideas of “same shape” and “scale factor” developed in the middle grades. These transformations lead to the criterion for triangle similarity that two pairs of corresponding angles are congruent.

Although the units in this instructional framework emphasize key standards and big ideas at specific times of the year, routine topics such as estimation, mental computation, and basic computation facts should be addressed on an ongoing basis. Ideas related to the eight practice standards should be addressed constantly as well. This unit provides much needed content information and excellent learning activities. However, the intent of the framework is not to provide a comprehensive resource for the implementation of all standards in the unit. A variety of resources should be utilized to supplement this unit. The tasks in this unit framework illustrate the types of learning activities that should be utilized from a variety of sources. To assure that this unit is taught with the appropriate emphasis, depth, and rigor, it is important that the “**Strategies for Teaching and Learning**” in the Comprehensive Course Overview and the tasks listed under “**Evidence of Learning**” be reviewed early in the planning process.

STANDARDS ADDRESSED IN THIS UNIT

Mathematical standards are interwoven and should be addressed throughout the year in as many different units and activities as possible in order to emphasize the natural connections that exist among mathematical topics.

KEY STANDARDS

Understand similarity in terms of similarity transformations

MGSE9-12.G.SRT.1 Verify experimentally the properties of dilations given by a center and a scale factor.

- a. The dilation of a line not passing through the center of the dilation results in a parallel line and leaves a line passing through the center unchanged.
- b. The dilation of a line segment is longer or shorter according to the ratio given by the scale factor.

MGSE9-12.G.SRT.2 Given two figures, use the definition of similarity in terms of similarity transformations to decide if they are similar; explain, using similarity transformations, the meaning of similarity for triangles as the equality of all corresponding pairs of angles and the proportionality of all corresponding pairs of sides.

MGSE9-12.G.SRT.3 Use the properties of similarity transformations to establish the AA criterion for two triangles to be similar.

Prove theorems involving similarity

MGSE9-12.G.SRT.4 Prove theorems about triangles. Theorems include: a line parallel to one side of a triangle divides the other two proportionally, (and its converse); the Pythagorean Theorem using triangle similarity.

MGSE9-12.G.SRT.5 Use congruence and similarity criteria for triangles to solve problems and to prove relationships in geometric figures.

Understand congruence in terms of rigid motions

MGSE9-12.G.CO.6 Use geometric descriptions of rigid motions to transform figures and to predict the effect of a given rigid motion on a given figure; given two figures, use the definition of congruence in terms of rigid motions to decide if they are congruent.

MGSE9-12.G.CO.7 Use the definition of congruence in terms of rigid motions to show that two triangles are congruent if and only if corresponding pairs of sides and corresponding pairs of angles are congruent.

MGSE9-12.G.CO.8 Explain how the criteria for triangle congruence (ASA, SAS, and SSS) follow from the definition of congruence in terms of rigid motions. (Extend to include HL and AAS.)

Prove geometric theorems

MGSE9-12.G.CO.9 Prove theorems about lines and angles. Theorems include: vertical angles are congruent; when a transversal crosses parallel lines, alternate interior angles are congruent and corresponding angles are congruent; points on a perpendicular bisector of a line segment are exactly those equidistant from the segment's endpoints.

MGSE9-12.G.CO.10 Prove theorems about triangles. Theorems include: measures of interior angles of a triangle sum to 180 degrees; base angles of isosceles triangles are congruent; the segment joining midpoints of two sides of a triangle is parallel to the third side and half the length; the medians of a triangle meet at a point.

MGSE9-12.G.CO.11 Prove theorems about parallelograms. Theorems include: opposite sides are congruent, opposite angles are congruent, the diagonals of a parallelogram bisect each other, and conversely, rectangles are parallelograms with congruent diagonals.

Make geometric constructions

MGSE9-12.G.CO.12 Make formal geometric constructions with a variety of tools and methods (compass and straightedge, string, reflective devices, paper folding, dynamic geometric software, etc.). Copying a segment; copying an angle; bisecting a segment; bisecting an angle; constructing perpendicular lines, including the perpendicular bisector of a line segment; and constructing a line parallel to a given line through a point not on the line.

MGSE9-12.G.CO.13 Construct an equilateral triangle, a square, and a regular hexagon, each inscribed in a circle.

STANDARDS FOR MATHEMATICAL PRACTICE

Refer to the Comprehensive Course Overview for more detailed information about the Standards for Mathematical Practice.

1. Make sense of problems and persevere in solving them.
2. Reason abstractly and quantitatively.
3. Construct viable arguments and critique the reasoning of others.
4. Model with mathematics.
5. Use appropriate tools strategically.
6. Attend to precision.
7. Look for and make use of structure.
8. Look for and express regularity in repeated reasoning.

SMP = Standards for Mathematical Practice

*Although the language of mathematical argument and justification is not explicitly expressed in the standards, it is embedded in the Standards for Mathematical Practice (3. Construct viable arguments and critique the reasoning of others.). Using conjecture, inductive reasoning, deductive reasoning, counterexamples and multiple methods of proof as appropriate is relevant to this and future units. Also, understanding the relationship between a statement and its converse, inverse and contrapositive is important.

ENDURING UNDERSTANDINGS

- Given a center and a scale factor, verify experimentally, that when dilating a figure in a coordinate plane, a segment of the pre-image that does not pass through the center of the dilation, is parallel to its image when the dilation is performed. However, a segment that passes through the center remains unchanged.
- Given a center and a scale factor, verify experimentally, that when performing dilations of a line segment, the pre-image, the segment which becomes the image is longer or shorter based on the ratio given by the scale factor.
- Use the idea of dilation transformations to develop the definition of similarity.

- Given two figures determine whether they are similar and explain their similarity based on the equality of corresponding angles and the proportionality of corresponding sides.
- Use the properties of similarity transformations to develop the criteria for proving similar triangles: AA.
- Use AA, SAS, SSS similarity theorems to prove triangles are similar.
- Prove a line parallel to one side of a triangle divides the other two proportionally, and its converse.
- Prove the Pythagorean Theorem using triangle similarity.
- Use similarity theorems to prove that two triangles are congruent.
- Use descriptions of rigid motion and transformed geometric figures to predict the effects rigid motion has on figures in the coordinate plane.
- Knowing that rigid transformations preserve size and shape or distance and angle, use this fact to connect the idea of congruency and develop the definition of congruent.
- Use the definition of congruence, based on rigid motion, to show two triangles are congruent if and only if their corresponding sides and corresponding angles are congruent.
- Use the definition of congruence, based on rigid motion, to develop and explain the triangle congruence criteria: ASA, SSS, and SAS.
- Prove vertical angles are congruent.
- Prove when a transversal crosses parallel lines, alternate interior angles are congruent and corresponding angles are congruent.
- Prove points on a perpendicular bisector of a line segment are exactly those equidistant from the segment's endpoints.
- Prove the measures of interior angles of a triangle have a sum of 180° .
- Prove base angles of isosceles triangles are congruent.
- Prove the segment joining midpoints of two sides of a triangle is parallel to the third side and half the length.
- Prove the medians of a triangle meet at a point.
- Prove properties of parallelograms including: opposite sides are congruent, opposite angles are congruent, diagonals of a parallelogram bisect each other, and conversely, rectangles are parallelograms with congruent diagonals.
- Copy a segment and an angle, and bisect a segment and an angle.
- Construct perpendicular lines, including the perpendicular bisector of a line segment.
- Construct a line parallel to a given line through a point not on the line.
- Construct an equilateral triangle a square and regular hexagon so that each vertex is on the circle.

ESSENTIAL QUESTIONS

- What is dilation and how does this transformation affect a figure in the coordinate plane?
- What strategies can I use to determine missing side lengths and areas of similar figures?
- Under what conditions are similar figures congruent?
- How do I know which method to use to prove two triangles congruent?

- How do I know which method to use to prove two triangles similar?
- How do I prove geometric theorems involving lines, angles, triangles, and parallelograms?
- In what ways can I use congruent triangles to justify many geometric constructions?
- How do I make geometric constructions?

CONCEPTS/SKILLS TO MAINTAIN

Some students often do not recognize that congruence is a special case of similarity. Similarity with a scale factor equal to 1 becomes a congruency. Students may not realize that similarities preserve shape, but not size. Angle measures stay the same, but side lengths change by a constant scale factor. Some students often do not list the vertices of similar triangles in order. However, the order in which vertices are listed is preferred and especially important for similar triangles so that proportional sides can be correctly identified. Dilations and similarity, including the AA criterion, are investigated in Grade 8, and these experiences should be built upon in high school with greater attention to precise definitions, careful statements and proofs of theorems and formal reasoning.

The Pythagorean Theorem and its converse are proved and applied in Grade 8. In high school, another proof, based on similar triangles, is presented. The alternate interior angle theorem and its converse, as well as properties of parallelograms, are established informally in Grade 8 and proved formally in high school.

Properties of lines and angles, triangles and parallelograms are investigated in Grades 7 and 8. In high school, these properties are revisited in a more formal setting, giving greater attention to precise statements of theorems and establishing these theorems by means of formal reasoning.

The theorem about the midline of a triangle can easily be connected to a unit on similarity. The proof of it is usually based on the similarity property that corresponding sides of similar triangles are proportional.

Students should be expected to have prior knowledge/experience related to the concepts and skills identified below. Pre-assessment may be necessary to determine whether instructional time should be spent on conceptual activities that help students develop a deeper understanding of these ideas.

- Understand and use reflections, translations, and rotations.
- Define the following terms: circle, bisector, perpendicular and parallel.
- Solve multi-step equations.
- Understand angle sum and exterior angle of triangles.
- Know angles created when parallel lines are cut by a transversal.
- Know facts about supplementary, complementary, vertical, and adjacent angles.
- Solve problems involving scale drawings of geometric figures.
- Draw geometric shapes with given conditions.
- Understand that a two-dimensional figure is congruent to another if the second can be obtained from the first by a sequence of rotations, reflections, and translations.

- Draw polygons in the coordinate plane given coordinates for the vertices.

SELECTED TERMS AND SYMBOLS

The following terms and symbols are often misunderstood. These concepts are not an inclusive list and should not be taught in isolation. However, due to evidence of frequent difficulty and misunderstanding associated with these concepts, instructors should pay particular attention to them and how their students are able to explain and apply them.

The definitions below are for teacher reference only and are not to be memorized by the students. Students should explore these concepts using models and real life examples. Students should understand the concepts involved and be able to recognize and/or demonstrate them with words, models, pictures, or numbers.

The websites below are interactive and include a math glossary suitable for middle school children. **Note – At the high school level, different sources use different definitions. Please preview any website for alignment to the definitions given in the frameworks.**

<http://www.amathsdictionaryforkids.com/>

This web site has activities to help students more fully understand and retain new vocabulary

<http://intermath.coe.uga.edu/dictionary/homepg.asp>

Definitions and activities for these and other terms can be found on the Intermath website. Intermath is geared towards middle and high school students.

- **Adjacent Angles:** Angles in the same plane that have a common vertex and a common side, but no common interior points.
- **Alternate Exterior Angles:** Alternate exterior angles are pairs of angles formed when a third line (a transversal) crosses two other lines. These angles are on opposite sides of the transversal and are outside the other two lines. When the two other lines are parallel, the alternate exterior angles are equal.
- **Alternate Interior Angles:** Alternate interior angles are pairs of angles formed when a third line (a transversal) crosses two other lines. These angles are on opposite sides of the transversal and are in between the other two lines. When the two other lines are parallel, the alternate interior angles are equal.
- **Angle:** Angles are created by two distinct rays that share a common endpoint (also known as a vertex). $\angle ABC$ or $\angle B$ denote angles with vertex B.
- **Bisector:** A bisector divides a segment or angle into two equal parts.
- **Centroid:** The point of concurrency of the medians of a triangle.

- **Circumcenter:** The point of concurrency of the perpendicular bisectors of the sides of a triangle.
- **Coincidental:** Two equivalent linear equations overlap when graphed.
- **Complementary Angles:** Two angles whose sum is 90 degrees.
- **Congruent:** Having the same size, shape and measure. Two figures are congruent if all of their corresponding measures are equal.
- **Congruent Figures:** Figures that have the same size and shape.
- **Corresponding Angles:** Angles that have the same relative positions in geometric figures.
- **Corresponding Sides:** Sides that have the same relative positions in geometric figures
- **Dilation:** Transformation that changes the size of a figure, but not the shape.
- **Endpoints:** The points at an end of a line segment
- **Equiangular:** The property of a polygon whose angles are all congruent.
- **Equilateral:** The property of a polygon whose sides are all congruent.
- **Exterior Angle of a Polygon:** an angle that forms a linear pair with one of the angles of the polygon.
- **Incenter:** The point of concurrency of the bisectors of the angles of a triangle.
- **Intersecting Lines:** Two lines in a plane that cross each other. Unless two lines are coincidental, parallel, or skew, they will intersect at one point.
- **Intersection:** The point at which two or more lines intersect or cross.
- **Inscribed Polygon:** A polygon is inscribed in a circle if and only if each of its vertices lie on the circle.
- **Line:** One of the basic undefined terms of geometry. Traditionally thought of as a set of points that has no thickness but its length goes on forever in two opposite directions. \overleftrightarrow{AB} denotes a line that passes through point A and B.
- **Line Segment or Segment:** The part of a line between two points on the line. \overline{AB} denotes a line segment between the points A and B.

- **Linear Pair:** Adjacent, supplementary angles. Excluding their common side, a linear pair forms a straight line.
- **Measure of each Interior Angle of a Regular n-gon:** $\frac{180^\circ (n - 2)}{n}$
- **Median of a Triangle:** A segment is a median of a triangle if and only if its endpoints are a vertex of the triangle and the midpoint of the side opposite the vertex.
- **Midsegment:** A line segment whose endpoints are the endpoint of two sides of a triangle is called a midsegment of a triangle.
- **Orthocenter:** The point of concurrency of the altitudes of a triangle.
- **Parallel Lines:** Two lines are parallel if they lie in the same plane and they do not intersect.
- **Perpendicular Bisector:** A perpendicular line or segment that passes through the midpoint of a segment.
- **Perpendicular Lines:** Two lines are perpendicular if they intersect at a right angle.
- **Plane:** One of the basic undefined terms of geometry. Traditionally thought of as going on forever in all directions (in two-dimensions) and is flat (i.e., it has no thickness).
- **Point:** One of the basic undefined terms of geometry. Traditionally thought of as having no length, width, or thickness, and often a dot is used to represent it.
- **Proportion:** An equation which states that two ratios are equal.
- **Ratio:** Comparison of two quantities by division and may be written as r/s, r:s, or r to s.
- **Ray:** A ray begins at a point and goes on forever in one direction.
- **Reflection:** A transformation that "flips" a figure over a line of reflection
- **Reflection Line:** A line that is the perpendicular bisector of the segment with endpoints at a pre-image point and the image of that point after a reflection.
- **Regular Polygon:** A polygon that is both equilateral and equiangular.
- **Remote Interior Angles of a Triangle:** the two angles non-adjacent to the exterior angle.
- **Rotation:** A transformation that turns a figure about a fixed point through a given angle and a given direction.

- **Same-Side Interior Angles:** Pairs of angles formed when a third line (a transversal) crosses two other lines. These angles are on the same side of the transversal and are between the other two lines. When the two other lines are parallel, same-side interior angles are supplementary.
- **Same-Side Exterior Angles:** Pairs of angles formed when a third line (a transversal) crosses two other lines. These angles are on the same side of the transversal and are outside the other two lines. When the two other lines are parallel, same-side exterior angles are supplementary.
- **Scale Factor:** The ratio of any two corresponding lengths of the sides of two similar figures.
- **Similar Figures:** Figures that have the same shape but not necessarily the same size.
- **Skew Lines:** Two lines that do not lie in the same plane (therefore, they cannot be parallel or intersect).
- **Sum of the Measures of the Interior Angles of a Convex Polygon:** $180^\circ(n - 2)$.
- **Supplementary Angles:** Two angles whose sum is 180 degrees.
- **Transformation:** The mapping, or movement, of all the points of a figure in a plane according to a common operation.
- **Translation:** A transformation that "slides" each point of a figure the same distance in the same direction
- **Transversal:** A line that crosses two or more lines.
- **Vertical Angles:** Two nonadjacent angles formed by intersecting lines or segments. Also called opposite angles.

EVIDENCE OF LEARNING

By the conclusion of this unit, students should be able to demonstrate the following competencies:

- enlarge or reduce a geometric figure using a given scale factor
- given a figure in the coordinate plane, determine the coordinates resulting from a dilation
- compare geometric figures for similarity and describe similarities by listing corresponding parts
- use scale factors, length ratios, and area ratios to determine side lengths and areas of similar geometric figures

Georgia Department of Education

Georgia Standards of Excellence Framework

GSE Geometry • Unit 2

- perform basic constructions using a straight edge and compass and describe the strategies used
- use congruent triangles to justify constructions
- show that two triangles are congruent if and only if corresponding pairs of sides and corresponding pairs of angles are congruent (CPCTC)
- identify the minimum conditions necessary for triangle congruence (ASA, SAS, and SSS)
- understand, explain, and demonstrate why ASA, SAS, or SSS are sufficient to show congruence
- prove theorems about lines and angles
- prove theorems about triangles
- prove properties of parallelograms

FORMATIVE ASSESSMENT LESSONS (FAL)

Formative Assessment Lessons are intended to support teachers in formative assessment. They reveal and develop students' understanding of key mathematical ideas and applications. These lessons enable teachers and students to monitor in more detail their progress towards the targets of the standards. They assess students' understanding of important concepts and problem solving performance, and help teachers and their students to work effectively together to move each student's mathematical reasoning forward.

More information on Formative Assessment Lessons may be found in the Comprehensive Course Overview.

SPOTLIGHT TASKS

A Spotlight Task has been added to each GSE mathematics unit in the Georgia resources for middle and high school. The Spotlight Tasks serve as exemplars for the use of the Standards for Mathematical Practice, appropriate unit-level Georgia Standards of Excellence, and research-based pedagogical strategies for instruction and engagement. Each task includes teacher commentary and support for classroom implementation. Some of the Spotlight Tasks are revisions of existing Georgia tasks and some are newly created. Additionally, some of the Spotlight Tasks are 3-Act Tasks based on 3-Act Problems from Dan Meyer and Problem-Based Learning from Robert Kaplinsky.

TASKS

The following tasks represent the level of depth, rigor, and complexity expected of all Geometry students. These tasks, or tasks of similar depth and rigor, should be used to demonstrate evidence of learning. It is important that all elements of a task be addressed throughout the learning process so that students understand what is expected of them. While some tasks are identified as a performance task, they may also be used for teaching and learning (learning/scaffolding task).

Task Name	Task Type <i>Grouping Strategy</i>	Content Addressed	SMPs Addressed
Introductory Activity (Spotlight Task)	Learning Task <i>Partner/Small Group Task</i>	Knowledge of properties and definitions of geometric shapes; constructing and critiquing arguments	3
Introducing Congruence (Spotlight Task)	Learning Task <i>Partner/Small Group Task</i>	Define congruence based on rigid motions	3, 5, 6, 7
Analyzing Congruency Proofs	Formative Assessment Lesson	Investigate methods for proving triangles congruent.	3, 5, 7
Formalizing triangle congruence (Spotlight Task)	Learning Task <i>Partner/Small Group Task</i>	Use definition of congruence to formalize ASA, SSS, SAS, AAS, and HL	2, 3
Triangle Proofs	Performance Task <i>Individual/Partner Task</i>	Prove theorems pertaining to triangles	1 – 4, 6 – 8
Lunch Lines	Performance Task <i>Individual/Partner Task</i>	Prove theorems about lines and angles of parallel lines cut by one or more transversals	1 – 6
Triangle Proportionality Theorem	Performance Task <i>Individual/Partner Task</i>	Properties of the ratio of segments of parallel lines cut by a transversal	1 – 8
Challenges from Ancient Greece	Constructing Task <i>Partner/Small Group Task</i>	Perform geometric constructions using Euclidean tools: copying line segments, copying an angle, bisecting a segment, and bisecting an angle	4 – 8
Constructing Parallel and Perpendicular Lines	Constructing Task <i>Partner/Small Group Task</i>	Perform geometric constructions using Euclidean tools: constructing parallel and perpendicular lines	4 – 8
Constructions Inscribed in a Circle	Constructing Task <i>Partner/Small Group Task</i>	Perform geometric constructions using Euclidean tools: constructing polygons inscribed in a circle	4 – 8

Georgia Department of Education
 Georgia Standards of Excellence Framework
GSE Geometry • Unit 2

Centers of a Triangle	Constructing Task <i>Partner/Small Group Task</i>	Prove the medians of a triangle meet at a point Bisect a segment and an angle Construct perpendicular lines, including the perpendicular bisector of a line segment	1 – 8
Constructing with Diagonals	Constructing Task <i>Partner/Small Group Task</i>	Prove theorems about parallelograms	1 – 8
Evaluating Statements about Length and Area	Formative Assessment Lesson	Evaluate the equality of areas for figures of different dimensions.	2, 3
Floor Pattern	Formative Assessment Task	Proving that a quadrilateral is a parallelogram. **Optional**	3, 7
Dilations in the Coordinate Plane	Scaffolding Task <i>Individual/Partner Task</i>	Dilating a figure in a coordinate plane Enlarge or reduce a geometric figure using a given scale factor	1, 4, 7, 8
Similar Triangles	Practice Task <i>Individual/Partner Task</i>	Discover the relationships that exist between similar figures using the scale factors, length ratios, and area ratios	1, 2, 4, 8
Shadow Math	Scaffolding Task <i>Individual/Partner Task</i>	Determine missing side lengths of similar figures	1 – 4
Proving Similar Triangles	Scaffolding Task <i>Individual/Partner Task</i>	Identify Similar Triangles Use similarity theorems to prove that two triangles are similar	3, 4
Hopewell Geometry	Formative Assessment Task	Prove right triangles are similar; use the Pythagorean Theorem to identify right triangles; includes right triangle trig to find angles	3, 7
Pythagorean Theorem using Triangle Similarity	Constructing Task <i>Partner/Small Group Task</i>	Prove the Pythagorean Theorem using triangle similarity	1 – 8
Solving Geometry Problems: Floodlights	Formative Assessment Lesson	Making mathematical models for similar triangles to solve an application problem.	1, 2, 4, 5, 7
Geometry Gardens	Culminating Task <i>Individual/Partner Task</i>	Recognize congruence of plane figures and verify through rigid motions Prove congruence using geometric theorems	1 – 8

Introductory Activity (Spotlight Task)

Standards Addressed in this Task

There are no geometry standards completely and explicitly addressed in this task. However, the background understandings and introduction to the ideas of argumentation and justification in this task are important for the rest of this unit.

Standards for Mathematical Practice

3. Construct viable arguments and critique the reasoning of others.

*Goals: Access student knowledge about geometry and transformations from previous courses
 Introduce the notions of justification and proof*

Investigate what is necessary for a mathematical proof – what convinces you may not convince your neighbor, your friend, or your teacher

Part 1

1. Brainstorm: What do you know about the following figures? List definitions and properties of each. *The important part of this question is accessing students' current understandings about these geometric shapes. While it is important for them to know the difference between definitions and properties, for this activity it is more important for them to generate as much information as they can about each shape so that the teacher can build on those understandings throughout this unit. Some sample information is inserted below.*

<p>Square <i>A quadrilateral with four equal sides and four right angles; opposite sides are parallel; diagonals are perpendicular and congruent; diagonals bisect each other</i></p>	<p>Rhombus <i>A quadrilateral with four equal sides; opposite sides are parallel; diagonals are perpendicular; diagonals bisect each other</i></p>	<p>Trapezoid <i>A quadrilateral with one pair of parallel sides</i></p>
<p>Rectangle <i>A quadrilateral with four right angles; opposite sides are parallel and congruent; diagonals bisect each other; diagonals are congruent</i></p>	<p>Parallelogram <i>A quadrilateral with both pairs of opposite sides parallel and congruent; diagonals bisect each other</i></p>	<p>Kite <i>A quadrilateral with two distinct pairs of equal adjacent sides; diagonals are perpendicular; angles between unequal sides are congruent</i></p>

Isosceles triangle <i>A triangle with two equal sides; base angles are congruent</i>	Right triangle <i>A triangle with one right angle</i>	Equilateral triangle <i>A triangle with three equal sides; all angles are congruent and equal to 60°</i>
---	--	---

Part 2

2. Brian thinks that every square is also a rectangle. He says this is so because a rectangle is a quadrilateral with four right angles and a square fits this definition. Is Brian right? Why or why not? Did Brian make a convincing argument? *Brian is correct. Every square is a rectangle because a square fits the definition of a rectangle: it is a quadrilateral with four right angles. His argument is convincing because he is using our familiar definition of a rectangle. Note: It is important that students understand that every square is a rectangle, but not every rectangle is a square.*

3. Consider the following set of figures on a coordinate plane.

a. Which of the following figures are parallelograms? How do you know?
ABCD, EFGH, IJKL, MNOP, QRST are parallelograms. Each of these figures has two pairs of parallel sides. I can tell the sides are parallel because they have the same slope. UVWX is not a parallelogram because the slope of UX is 3 while the slope of VW is 4.

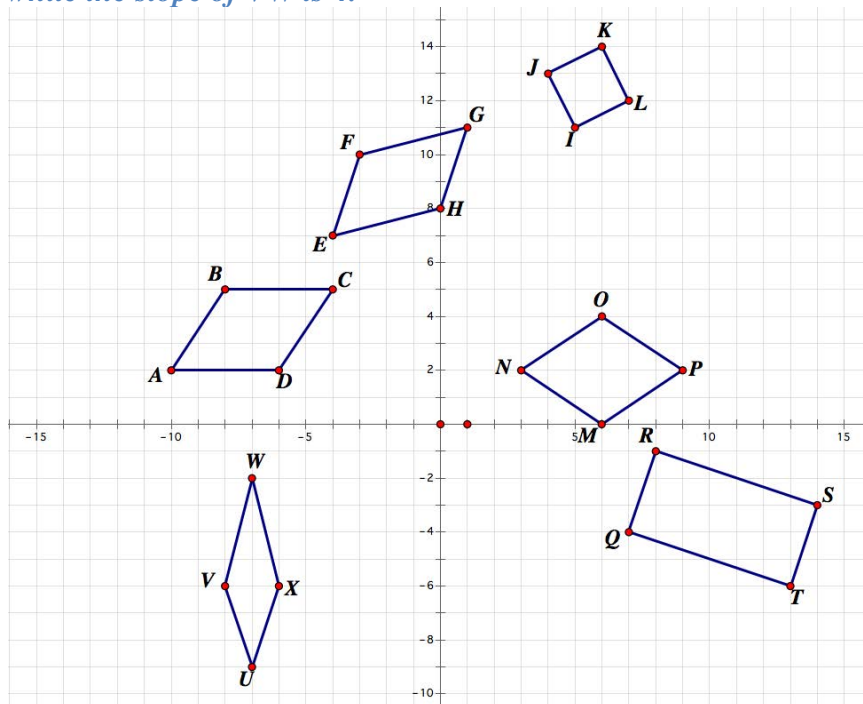

b. Can you identify all of the parallelograms? Write an argument that would convince a skeptic that you have found all of the parallelograms in this figure.

I checked each of the figures in the diagram.

ABCD is a parallelogram because the slope of $AD = \text{slope of } BC = 0$ and the slope of $AB = \text{slope of } DC = 3/2$.

EFGH is a parallelogram because the slope of $EF = \text{slope of } GH = 3$ and the slope of $FG = \text{slope of } EH = 1/4$

IJKL is a parallelogram because the slope of $IJ = \text{slope of } KL = -2$ and the slope of $JK = \text{slope of } IL = 1/2$

MNOP is a parallelogram because the slope of $NO = \text{slope of } MP = 2/3$ and the slope of $NM = \text{slope of } OP = -2/3$

QRST is a parallelogram because the slope of $QR = \text{slope of } TS = 3$ and the slope of $RS = \text{slope of } QT = -1/3$

UVWX is not a parallelogram because the slope of UX is 3 while the slope of VW is 4

- c. Could you classify any of the parallelograms as another type of mathematical shape? If so, which ones? If not, why not?

IJKL is a square because the slope of $IJ = \text{slope of } KL = -2$ and the slope of $JK = \text{slope of } IL = 1/2$. -2 and $1/2$ are opposite reciprocals, so KL is perpendicular to JK , and thus these are 90° angles. Also, by the distance formula, $|JK| = |KL| = |LI| = |IJ| = \sqrt{3}$, so all sides are equal.

QRST is a rectangle because the slope of $QR = \text{slope of } TS = 3$ and the slope of $RS = \text{slope of } QT = -1/3$. $-1/3$ and 3 are opposite reciprocals, so QR is perpendicular to RS , and thus these are 90° angles. By the distance formula, $|QR| = \sqrt{10}$ and $|RS| = \sqrt{45}$, so $|QR| \neq |RS|$ and this is not a square.

MNOP is a rhombus because $|NO| = |OP| = |PM| = |MN| = \sqrt{13}$, so the sides are equal but there are no 90° angles since the slopes ($2/3$ and $-2/3$) are not opposite reciprocals.

UVWZ is a kite because VW and WX are adjacent and $|VW| = |WX| = \sqrt{17}$; XU and UV are adjacent and $|XU| = |UV| = \sqrt{10}$

The other two figures have neither opposite reciprocal slopes nor adjacent congruent sides.

4. Martin and Simone were given quadrilateral ABCD on a coordinate plane:

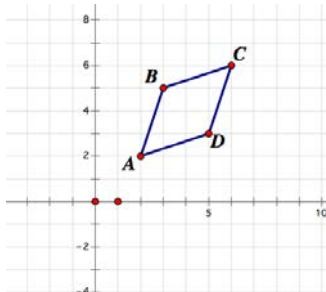

Martin said: “Quadrilateral ABCD is a rhombus because $AB \parallel DC$ and $AD \parallel BC$ and it doesn’t have any right angles.”

Simone said: “Quadrilateral ABCD is a rhombus because it has two pairs of parallel sides and $AB=BC=CD=DA$.”

Whose argument is better? Why? Can you write a more precise mathematical argument than Martin and Simone?

Simone's argument is better, as it addresses both defining characteristics of a rhombus.

Georgia Department of Education

Georgia Standards of Excellence Framework

GSE Geometry • Unit 2

A more precise mathematical argument might include naming the parallel sides and even giving the values for the slopes and lengths of sides. The fact that it has no right angles is pertinent to it not being a square, but since a square is a rhombus, that information is not relevant to the argument that this is a rhombus.

When asking students to construct or critique an argument consider asking them to identify the claim they or another student is making and then to note what information they have that is relevant to that claim. They should then explain why that information is helpful or important to making that claim. We can consider this to be giving a claim, providing data for that claim, and then writing a warrant to describe why the data supports the claim. Thinking about claims, data and warrants can make arguments more approachable for students.

Introductory Activity (Spotlight Task)

Part 1

1. Brainstorm: What do you know about the following figures? List definitions and properties of each.

Square	Rhombus	Trapezoid
Rectangle	Parallelogram	Kite
Isosceles triangle	Right triangle	Equilateral triangle

Part 2

2. Brian thinks that every square is also a rectangle. He says this is so because a rectangle is a quadrilateral with four right angles and a square fits this definition. Is Brian right? Why or why not? Did Brian make a convincing argument?

3. Consider the following set of figures on a coordinate plane.
- a. Which of the following figures are parallelograms? How do you know?

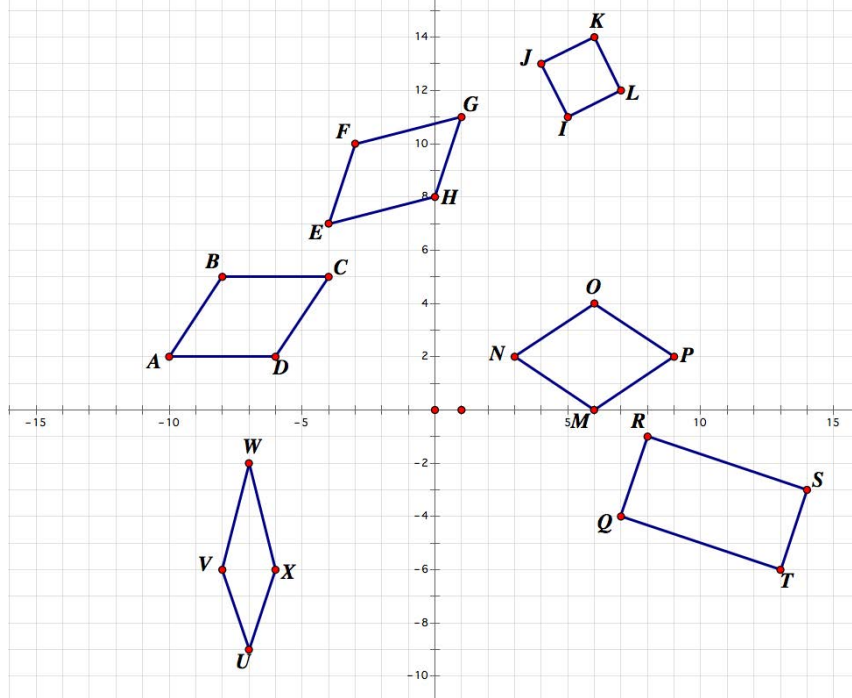

- b. Can you identify all of the parallelograms? Write an argument that would convince a skeptic that you have found all of the parallelograms in this figure.
- c. Could you classify any of the parallelograms as another type of mathematical shape? If so, which ones? If not, why not?

4. Martin and Simone were given quadrilateral ABCD on a coordinate plane:

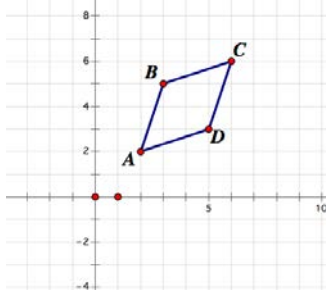

Martin said: “Quadrilateral ABCD is a rhombus because $AB \parallel DC$ and $AD \parallel BC$ and it doesn't have any right angles.”

Simone said: “Quadrilateral ABCD is a rhombus because it has two pairs of parallel sides and $AB=BC=CD=DA$.”

Whose argument is better? Why? Can you write a more precise mathematical argument than Martin and Simone?

Introducing Congruence (Spotlight Task)

(Congruence in terms of rigid motions)

Standards Addressed in this Task

MGSE9-12.G.CO.6 Use geometric descriptions of rigid motions to transform figures and to predict the effect of a given rigid motion on a given figure; given two figures, use the definition of congruence in terms of rigid motions to decide if they are congruent.

MGSE9-12.G.CO.7 Use the definition of congruence in terms of rigid motions to show that two triangles are congruent if and only if corresponding pairs of sides and corresponding pairs of angles are congruent.

Standards for Mathematical Practice

3. Construct viable arguments and critique the reasoning of others by engaging students on discussion of why they agree or disagree with responses, decide whether they make sense, and ask useful questions to clarify or improve the arguments.

5. Use appropriate tools strategically by expecting students to consider available tools when solving a mathematical problem. These tools might include pencil and paper, concrete models, a ruler, a protractor, a compass, a calculator, software, etc.

6. Attend to precision by requiring students to calculate efficiently and accurately; and to communicate precisely with others by using clear mathematical language to discuss their reasoning.

7. Look for and make use of structure by expecting students to apply rules, look for patterns and analyze structure.

Definition: Two triangles are congruent if and only if one can be obtained from the other by a sequence of rigid motions (translations, reflections, rotations)

From Coordinate Algebra, how can we tell if a figure is a translation, reflection, or rotation of another figure?

Triangle DEF is congruent to triangle ABC ($\triangle DEF \cong \triangle ABC$) because $\triangle DEF$ is a translation of $\triangle ABC$.

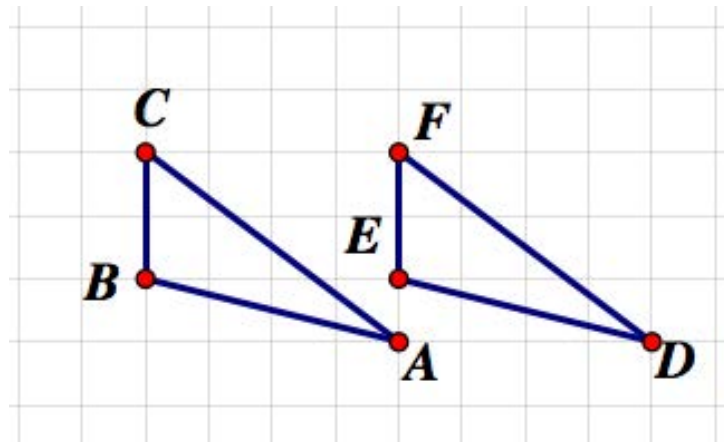

If $\triangle DEF$ is a translation of $\triangle ABC$, then what is true about the various sides and angles of the triangles? Specifically, what parts of these two triangles are related, and how are they related?

The corresponding sides and angles of these triangles are congruent.

$\overline{CB} \cong \overline{FE}$, $\overline{BA} \cong \overline{ED}$, $\overline{AC} \cong \overline{DF}$, $\angle A \cong \angle D$, $\angle C \cong \angle F$, and $\angle B \cong \angle E$.

In general, what can you say about sides and angles of figures that are translations, reflections, or rotations of other figures?

The corresponding sides and angles of these figures are congruent.

So then, if two triangles are congruent (and congruence depends on translations, reflections, and rotations), then what must be true about their sides and angles?

Their corresponding sides and angles are congruent.

Are the triangles in this figure congruent? Why or why not?

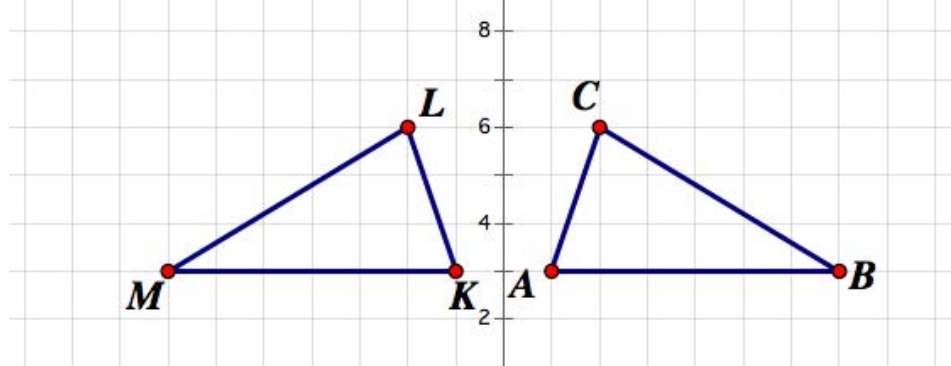

Yes, these triangles are congruent. $\triangle KML$ is a reflection of $\triangle ABC$ over the y-axis.

Are these triangles congruent? Why or why not?

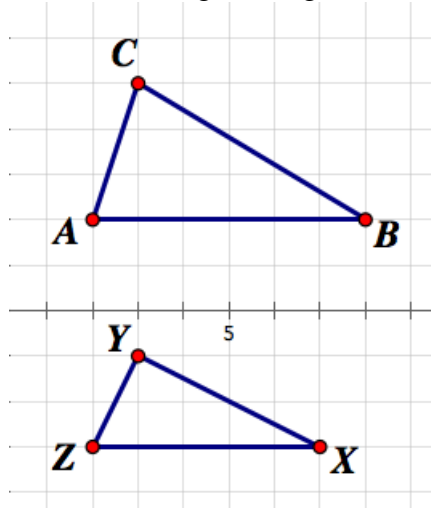

These triangles are not congruent. There is no rigid motion that maps one to the other. And, for example, \overline{AB} is not congruent to its corresponding side, \overline{ZX} .

What sequence of rigid motions maps $\triangle DGL$ to $\triangle CNB$? Which parts of these triangles must be congruent?

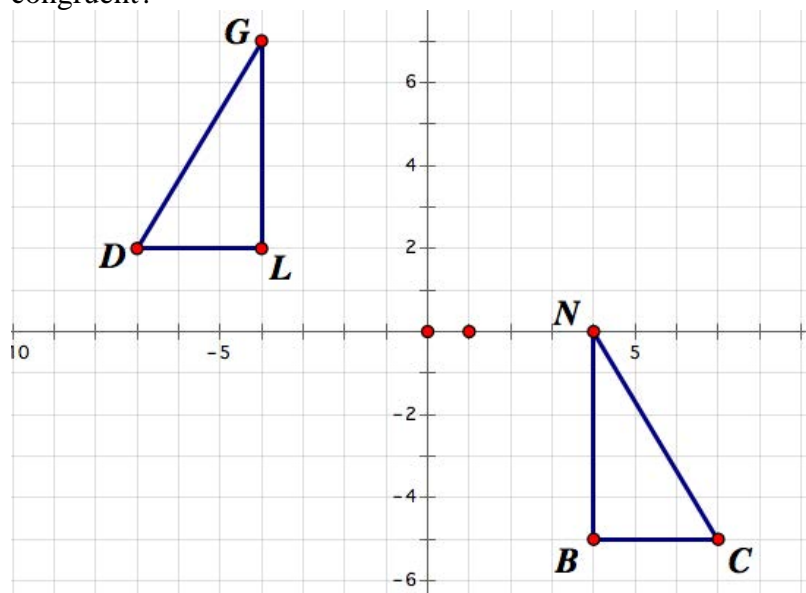

A reflection over the y-axis and then a translation down by 7 units.

$\overline{NC} \cong \overline{GD}$, $\overline{NB} \cong \overline{GL}$,
 $\overline{BC} \cong \overline{LD}$, $\angle N \cong \angle G$,
 $\angle C \cong \angle D$, and $\angle B \cong \angle L$

Introducing Congruence (Spotlight Task) (Congruence in terms of rigid motions)

Standards Addressed in this Task

MGSE9-12.G.CO.6 Use geometric descriptions of rigid motions to transform figures and to predict the effect of a given rigid motion on a given figure; given two figures, use the definition of congruence in terms of rigid motions to decide if they are congruent.

MGSE9-12.G.CO.7 Use the definition of congruence in terms of rigid motions to show that two triangles are congruent if and only if corresponding pairs of sides and corresponding pairs of angles are congruent.

Standards for Mathematical Practice

3. Construct viable arguments and critique the reasoning of others by engaging students on discussion of why they agree or disagree with responses, decide whether they make sense, and ask useful questions to clarify or improve the arguments.

5. Use appropriate tools strategically by expecting students to consider available tools when solving a mathematical problem. These tools might include pencil and paper, concrete models, a ruler, a protractor, a compass, a calculator, software, etc.

6. Attend to precision by requiring students to calculate efficiently and accurately; and to communicate precisely with others by using clear mathematical language to discuss their reasoning.

7. Look for and make use of structure by expecting students to apply rules, look for patterns and analyze structure.

Definition: Two triangles are congruent if and only if one can be obtained from the other by a sequence of rigid motions (translations, reflections, rotations)

From Coordinate Algebra, how can we tell if a figure is a translation, reflection, or rotation of another figure?

Triangle DEF is congruent to triangle ABC ($\triangle DEF \cong \triangle ABC$) because $\triangle DEF$ is a translation of $\triangle ABC$.

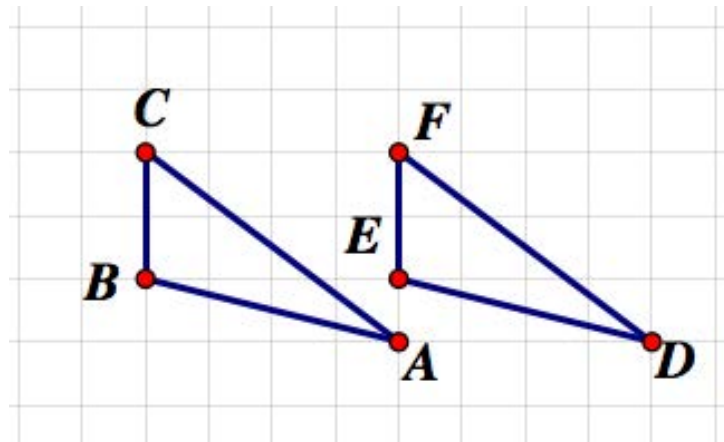

If $\triangle DEF$ is a translation of $\triangle ABC$, then what is true about the various sides and angles of the triangles? Specifically, what parts of these two triangles are related, and how are they related?

In general, what can you say about sides and angles of figures that are translations, reflections, or rotations of other figures?

So then, if two triangles are congruent (and congruence depends on translations, reflections, and rotations), then what must be true about their sides and angles?

Are these triangles congruent? Why or why not?

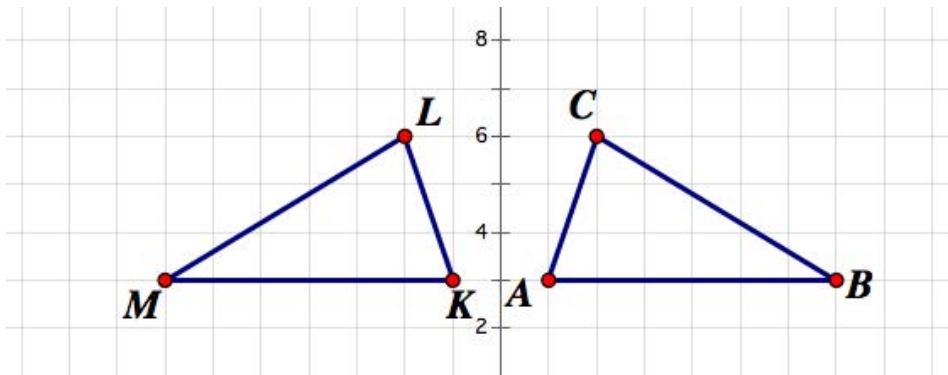

Are these triangles congruent? Why or why not?

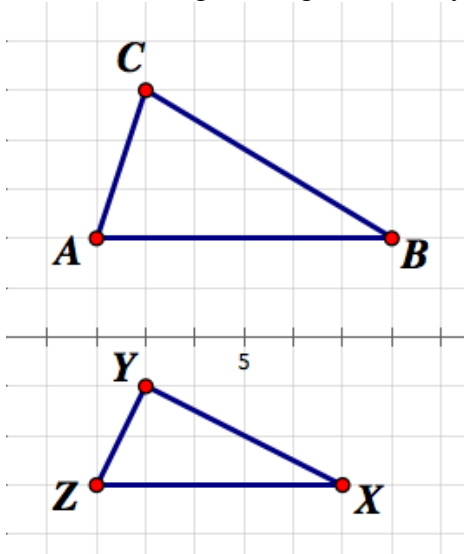

What sequence of rigid motions maps $\triangle DGL$ to $\triangle CNB$?

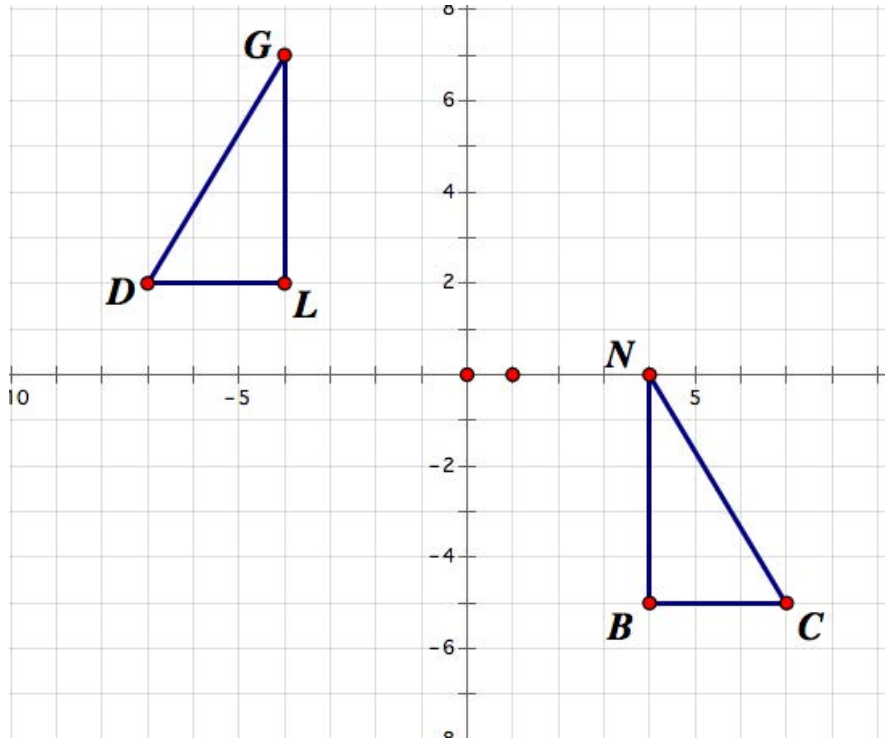

Which parts of these triangles must be congruent?

Formative Assessment Lesson: Analyzing Congruency Proofs

Source: *Formative Assessment Lesson Materials from Mathematics Assessment Project*
<http://map.mathshell.org/materials/download.php?fileid=1302>

ESSENTIAL QUESTION:

- How are triangles proven to be congruent?

TASK COMMENTS:

Tasks and lessons from the Mathematics Assessment Project are specifically designed to help teachers effectively formatively assess their students. The way the tasks and lessons are designed gives the teacher a clear understanding of what the students are able to do and not do. Within the lesson, teachers will find suggestions and question prompts that will help guide students towards understanding. For more information access the MAP website:

<http://www.map.mathshell.org/materials/background.php?subpage=formative>

The task, *Analyzing Congruency Proofs*, is a Formative Assessment Lesson (FAL) that can be found at the website: <http://map.mathshell.org/materials/lessons.php?taskid=452&subpage=concept>

The FAL document provides a clear lesson design, from the opening of the lesson to the closing of the lesson.

The PDF version of the task can be found at the link below:
<http://map.mathshell.org/materials/download.php?fileid=1302>

STANDARDS ADDRESSED IN THIS TASK:

Understand similarity in terms of similarity transformations

MGSE9-12.G.SRT.1 Verify experimentally the properties of dilations given by a center and a scale factor.

- a. The dilation of a line not passing through the center of the dilation results in a parallel line and leaves a line passing through the center unchanged.
- b. The dilation of a line segment is longer or shorter according to the ratio given by the scale factor.

MGSE9-12.G.SRT.2 Given two figures, use the definition of similarity in terms of similarity transformations to decide if they are similar; explain, using similarity transformations, the meaning of similarity for triangles as the equality of all corresponding pairs of angles and the proportionality of all corresponding pairs of sides.

MGSE9-12.G.SRT.3 Use the properties of similarity transformations to establish the AA criterion for two triangles to be similar.

Understand congruence in terms of rigid motions

MGSE9-12.G.CO.6 Use geometric descriptions of rigid motions to transform figures and to predict the effect of a given rigid motion on a given figure; given two figures, use the definition of congruence in terms of rigid motions to decide if they are congruent.

MGSE9-12.G.CO.7 Use the definition of congruence in terms of rigid motions to show that two triangles are congruent if and only if corresponding pairs of sides and corresponding pairs of angles are congruent.

MGSE9-12.G.CO.8 Explain how the criteria for triangle congruence (ASA, SAS, and SSS) follow from the definition of congruence in terms of rigid motions. (Extend to include HL and AAS.)

Standards for Mathematical Practice

This lesson uses all of the practices with emphasis on:

- 3. Construct viable arguments and critique the reasoning of others** by engaging students on discussion of why they agree or disagree with responses, decide whether they make sense, and ask useful questions to clarify or improve the arguments.
- 5. Use appropriate tools strategically** by expecting students to consider available tools when solving a mathematical problem. These tools might include pencil and paper, concrete models, a ruler, a protractor, a compass, a calculator, software, etc.
- 7. Look for and make use of structure** by expecting students to apply rules, look for patterns and analyze structure.

Formalizing Triangle Congruence Theorems

Standards Addressed in this Task

MGSE9-12.G.CO.8 Explain how the criteria for triangle congruence (ASA, SAS, and SSS) follow from the definition of congruence in terms of rigid motions. (Extend to include HL and AAS.)

Standards for Mathematical Practice

2. Reason abstractly and quantitatively.
3. Construct viable arguments and critique the reasoning of others.

The goal of this task is to take the general ideas encountered in the previous lesson (informal ideas about proving triangles congruent using different information) and establish which sets of information about triangles can actually establish congruence, given our definition of congruence as related to rigid motions. It is important to build on the intuitive ideas established in the previous task so that students make sense of the arguments they are examining and creating in this lesson.

An example of proving SAS Triangle Congruence by basic rigid motions can be found at the following site: <http://vimeo.com/45773877>.

Similar proofs for SSS and ASA can be found on the Illustrative Mathematics site

(<https://www.illustrativemathematics.org/illustrations/110>

and <https://www.illustrativemathematics.org/illustrations/339>). One possibility for engaging students in these ideas without the teacher walking them through each step is to assign groups of students to each of the theorems, providing some guidance or even access to the sites mentioned, and asking the groups to prepare a presentation to the class where they explain the arguments in their own words.

After students understand they can use SAS, ASA, and SSS, we can choose problems strategically to demonstrate the efficacy of AAS and HL. We can show AAS by reducing to ASA, and HL by reducing to either SSS or ASA.

By the end of this activity, students should understand that they can use SSS, ASA, SAS, AAS, and HL as theorems to prove triangles congruent without having to rely on the definition of congruence as it relates to rigid motions. They should understand that this greatly simplifies the amount and complexity of information needed to prove triangles congruent, and they should be able to prove triangles are congruent given the appropriate information. These proofs do not need to be in two-column form; in fact, paragraph proofs or flow chart proofs are just as appropriate.

Statements such as the following could be given to groups, with several groups getting the same statement, depending on the number of students in the class:

Challenge 1: You have two triangles, and you know that two sides of one triangle are congruent to two sides of the other triangle. You also know that the angle between the two known sides in the first triangle is congruent to the angle between the two known sides in the second triangle. Sketch the triangles and label the known information. Can you show that the two triangles are congruent? Hint: You should use what you know about congruence and rigid motions.

The arguments for congruence should include the following:

A sketch with both triangles labeled.

A translation that takes a vertex of one triangle to the corresponding vertex of the other triangle.

A rotation around the vertex from above that takes the adjacent side of the first triangle to the corresponding side of the second triangle.

A reflection about the line through the side from above and a rationale for why the triangles are now coincident.

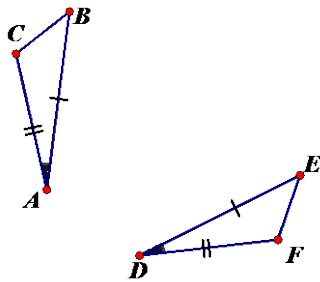

Construct vector \overline{AD} and translate triangle ABC by \overline{AD} . (Though students will not use vector terminology, they should express that the translation of the triangle is of distance AD and all points traverse in a direction parallel to \overline{AD} .)

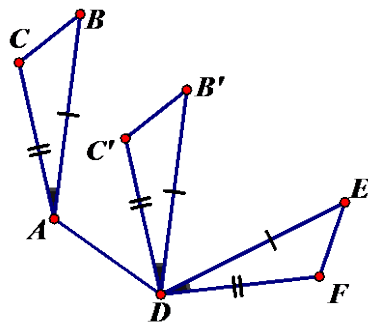

Rotate the new triangle ($A'B'C'$) so that $\overline{A'B'}$ lies on \overline{DE} . Because this is a rotation and preserves distance, B' is now coincident with E since we know that $AB=DE$.

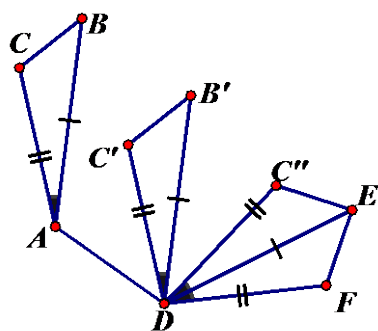

Construct line DE and reflect the new triangle ($A''B''C''$) over line DE . Because this is a reflection and preserves angle measure, $\angle EDF \cong \angle BAC$, so \overline{AC} lies on \overline{DF} . Then, because $\overline{AC} \cong \overline{DF}$, C is coincident with F , and the triangles are congruent since one was obtained from the other by a sequence of rigid motions (in this case, a translation, rotation, and a reflection).

Note: It is important that students recognize that these transformations were not done for a specific set of triangles, but this set of rigid motions would be valid for any triangles for which we had the given congruence information.

Challenge 2: You have two triangles, and you know that two angles of one triangle are congruent to two angles of the other triangle. You also know that the side between the two known angles in the first triangle is congruent to the side between the two known angles in the second triangle. Sketch the triangles and label the known information. Can you show that the two triangles are congruent? Hint: You should use what you know about congruence and rigid motions.

A sample argument:

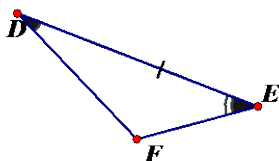
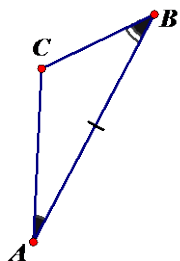

Construct vector \overline{AD} and translate triangle ABC by \overline{AD} . (Though students will not use vector terminology, they should express that the translation of the triangle is of distance AD and all points traverse in a direction parallel to \overline{AD} .)

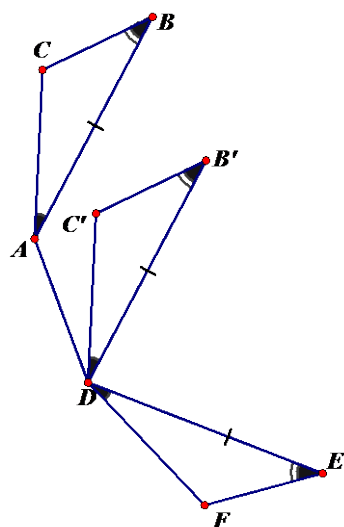

Rotate the new triangle ($A'B'C'$) so that $\overline{A'B'}$ lies on \overline{DE} . Because this is a rotation and preserves distance, B' is now coincident with E since we know that $AB=DE$.

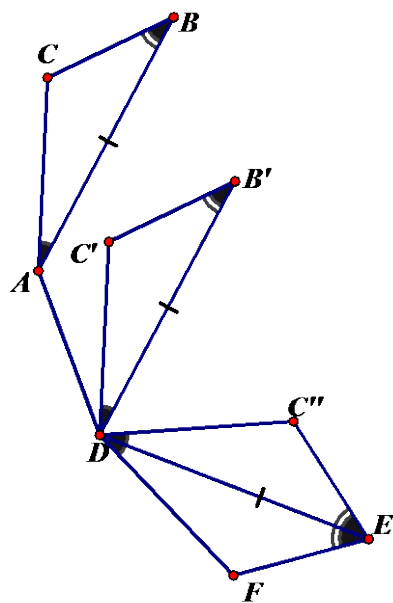

Construct line DE and reflect the new triangle ($A''B''C''$) over line DE . Because this is a reflection and preserves angle measure, $\angle EDF \cong \angle BAC$, so ray AC is coincident with ray DF ; likewise, because $\angle DEF \cong \angle ABC$, ray BC is coincident with ray EF . Rays DF and EF intersect in only one point, F , thus C coincides with F , and the triangles are congruent since one was obtained from the other by a sequence of rigid motions (in this case, a translation, rotation, and a reflection).

Challenge 3: You have two triangles, and you know that three sides of one triangle are congruent to three sides of the other triangle. Sketch the triangles and label the known information. Can you show that the two triangles are congruent? Hint: You should use what you know about congruence and rigid motions.

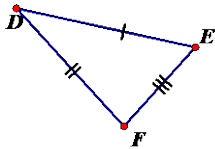
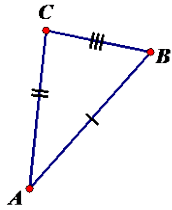

Construct vector \overrightarrow{AD} and translate triangle ABC by \overrightarrow{AD} . (Though students will not use vector terminology, they should express that the translation of the triangle is of distance AD and all points traverse in a direction parallel to \overrightarrow{AD} .)

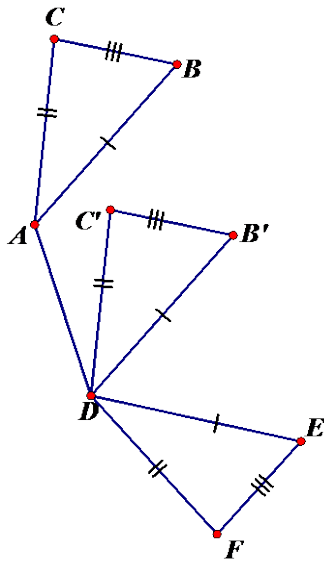

Rotate the new triangle ($A'B'C'$) so that $\overline{A'B'}$ lies on \overline{DE} . Because this is a rotation and preserves distance, B' is now coincident with E since we know that $AB=DE$.

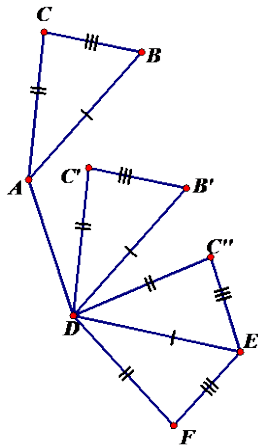

Construct line DE and reflect the new triangle ($A''B''C''$) over line DE . To show that C''' coincides with F , we can construct two circles, one centered at E with radius $|EF|$ and one centered at D with radius $|DF|$. Notice that because $|EF| = |EC|$ that the circle centered at E goes through both F and C'' . Likewise the circle centered at D passes through both F and C'' . Since two circles can intersect in at most two points, the reflection takes C'' to F as desired.

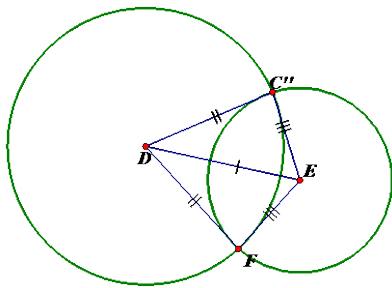

Part 2:

Aiden and Noah were given the following diagram of two triangles with the congruent parts marked.

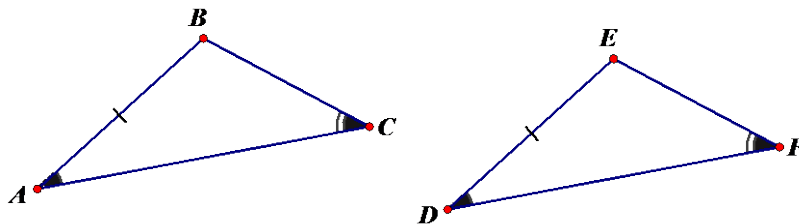

Aiden says that you cannot tell whether the two triangles are congruent because the side is not between the two given angles.

Noah says that the triangles are congruent because he knows that the third angles in the triangles have to be congruent, and then you have a side between two angles.

Are the triangles congruent? Can you tell? Do you agree with Aiden or Noah? Revise the argument with which you agree to make it more convincing.

The triangles are congruent. Noah is correct.

Revised argument: We can calculate $\angle B$ if we know the other two angles by subtracting their sum from 180° . So $m\angle B = 180 - (m\angle A + m\angle C)$. Similarly, $m\angle E = 180 - (m\angle D + m\angle F)$. Since $\angle A \cong \angle D$ and $\angle C \cong \angle F$, $m\angle B = m\angle E$ by the transitive property, so $\angle B \cong \angle E$. Then we have two corresponding angles and the included side congruent in the triangles and can conclude the triangles are congruent by ASA as we found earlier.

Tillie and Payton were given the following diagram of two right triangles with congruent parts marked.

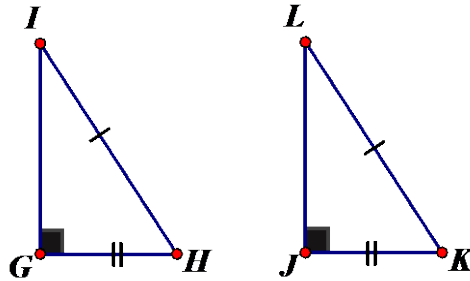

Tillie says this is a situation where you have two sides without the angle between them, so you can't tell if the triangles are congruent.

Payton says that the triangles are congruent because she can find the length of the third side in a right triangle and then use SSS, since all three corresponding sides must be congruent.

Are the triangles congruent? Can you tell? Do you agree with Tillie or Payton? Revise the argument with which you agree to make it more convincing.

The triangles are congruent. Payton is correct.

Revised argument: We can calculate $|GI|$ and $|JL|$ by the Pythagorean Theorem. $|GI| = \sqrt{|GH|^2 + |HI|^2} = \sqrt{|JK|^2 + |KL|^2}$ because $\overline{GH} \cong \overline{JK}$ and $\overline{HI} \cong \overline{KL}$. $|JL| = \sqrt{|JK|^2 + |KL|^2}$, thus, by the transitive property, $\overline{GI} \cong \overline{JL}$. So, by SSS, as shown above, the triangles must be congruent.

Formalizing Triangle Congruence Theorems

Standards Addressed in this Task

MGSE9-12.G.CO.8 Explain how the criteria for triangle congruence (ASA, SAS, and SSS) follow from the definition of congruence in terms of rigid motions. (Extend to include HL and AAS.)

Standards for Mathematical Practice

- Reason abstractly and quantitatively.
- Construct viable arguments and critique the reasoning of others.

Part 1:

Challenge 1: You have two triangles, and you know that two sides of one triangle are congruent to two sides of the other triangle. You also know that the angle between the two known sides in the first triangle is congruent to the angle between the two known sides in the second triangle. Sketch the triangles and label the known information. Can you show that the two triangles are congruent? Hint: You should use what you know about congruence and rigid motions.

Challenge 2: You have two triangles, and you know that two angles of one triangle are congruent to two angles of the other triangle. You also know that the side between the two known angles in the first triangle is congruent to the side between the two known angles in the second triangle. Sketch the triangles and label the known information. Can you show that the two triangles are congruent? Hint: You should use what you know about congruence and rigid motions.

Challenge 3: You have two triangles, and you know that three sides of one triangle are congruent to three sides of the other triangle. Sketch the triangles and label the known information. Can you show that the two triangles are congruent? Hint: You should use what you know about congruence and rigid motions.

Part 2:

Aiden and Noah were given the following diagram of two triangles with the congruent parts marked.

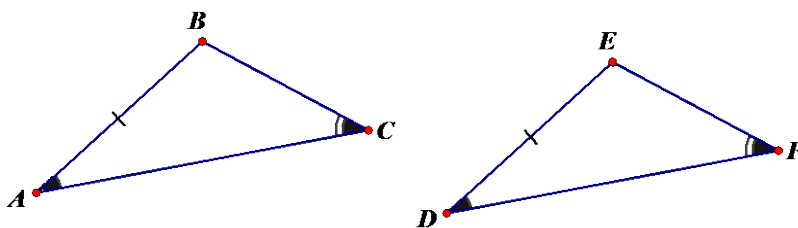

Aiden says that you cannot tell whether the two triangles are congruent because the side is not between the two given angles.

Noah says that the triangles are congruent because he knows that the third angles in the triangles have to be congruent, and then you have a side between two angles.

Are the triangles congruent? Can you tell? Do you agree with Aiden or Noah? Revise the argument with which you agree to make it more convincing.

Tillie and Payton were given the following diagram of two right triangles with congruent parts marked.

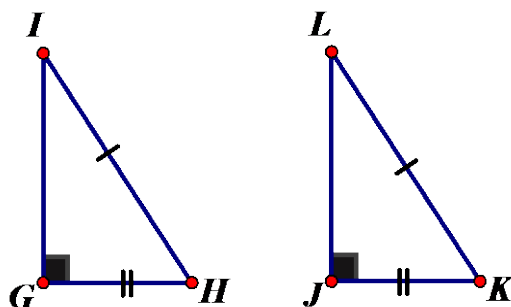

Tillie says this is a situation where you have two sides without the angle between them, so you can't tell if the triangles are congruent.

Payton says that the triangles are congruent because she can find the length of the third side in a right triangle and then use SSS, since all three corresponding sides must be congruent.

Are the triangles congruent? Can you tell? Do you agree with Tillie or Payton? Revise the argument with which you agree to make it more convincing.

Triangle Proofs

Mathematical Goals

- Prove theorems pertaining to triangles.

STANDARDS ADDRESSED IN THIS TASK

MGSE9-12.G.CO.10 Prove theorems about triangles. Theorems include: measures of interior angles of a triangle sum to 180 degrees; base angles of isosceles triangles are congruent; the segment joining midpoints of two sides of a triangle is parallel to the third side and half the length; the medians of a triangle meet at a point.

Standards for Mathematical Practice

1. **Make sense of problems and persevere in solving them** by requiring students to interpret and make meaning of a problem and find a logical starting point, and to monitor their progress and change their approach to solving the problem, if necessary.
2. **Reason abstractly and quantitatively** by requiring students to make sense of quantities and their relationships to one another in problem situations.
3. **Construct viable arguments and critique the reasoning of others** by engaging students on discussion of why they agree or disagree with responses, decide whether they make sense, and ask useful questions to clarify or improve the arguments.
4. **Model with mathematics** by expecting students to apply the mathematics concepts they know in order to solve problems arising in everyday situations, and reflect on whether the results are sensible for the given scenario.
5. **Use appropriate tools strategically** by expecting students to consider available tools when solving a mathematical problem. These tools might include pencil and paper, concrete models, a ruler, a protractor, a compass, a calculator, software, etc.
6. **Attend to precision** by requiring students to calculate efficiently and accurately; and to communicate precisely with others by using clear mathematical language to discuss their reasoning.
7. **Look for and make use of structure** by expecting students to apply rules, look for patterns and analyze structure.
8. **Look for and express regularity in repeated reasoning** by expecting students to understand broader applications and look for structure and general methods in similar situations.

Student Misconceptions

Research over the last four decades suggests that student misconceptions about proof abound:

1. Even after proving a generalization, students believe that exceptions to the generalization might exist;
2. One counterexample is not sufficient;

3. The converse of a statement is true (parallel lines do not intersect, lines that do not intersect are parallel; and
 4. A conjecture is true because it worked in all examples that were explored.

Each of these misconceptions needs to be addressed, both by the ways in which formal proof is taught in geometry and how ideas about “justification” are developed throughout a student’s mathematical education.

Introduction

This task provides students an opportunity to prove several triangles theorems including the measure of interior angles of a triangle sum to 180 degrees, base angles of isosceles triangles are congruent, and the segment joining midpoints of two sides of a triangle is parallel to the third side and half the length. Students will review CPCTC (Corresponding Parts of Congruent Triangles are Congruent) before beginning the proofs. Encourage multiple ways of writing proofs, such as in narrative paragraphs, using flow diagrams, in two-column format, and using diagrams without words.

Materials

- Patty paper

Corresponding
 Parts of
 Congruent
 Triangles are
 Congruent

Remember the definition of congruent figures?

If two geometric figures are congruent, then their corresponding parts are congruent.

Example: In the figure below, how do we know that $\triangle ABC \cong \triangle DBC$?

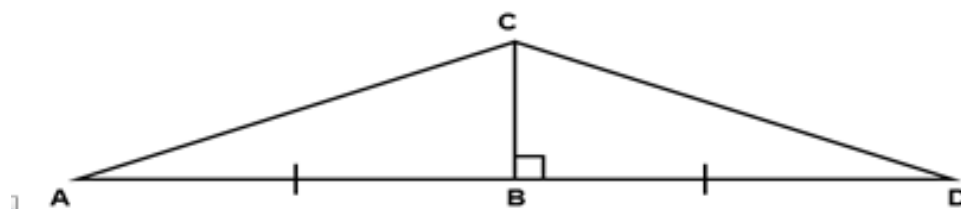

Statements	Reason
1. $\overline{AB} \cong \overline{BD}$	1. Given
2. $\angle ABC \cong \angle DBC$	2. By Euclid’s Perpendicular Postulate
3. $\overline{CB} \cong \overline{CB}$	3. Reflexive Property of Congruence
4. $\triangle ABC \cong \triangle DBC$	4. SAS Postulate

... And now that we know that the two triangles are congruent then by CPCTC all the other corresponding parts are congruent as well.

$$\begin{aligned} \angle A &\cong \angle D \\ \angle ACB &\cong \angle DCB \\ \overline{AC} &\cong \overline{DC} \end{aligned}$$

Let's start proving theorems about triangles using two column proofs. Fill in the missing statements and reasons in the proof below.

Theorem: The sum of the measure of the angles of any triangle is 180° .

Proof:

Given: The top line (that touches the top of the triangle) is parallel to the base of the triangle.

Prove: $m\angle 1 + m\angle 3 + m\angle 2 = 180^\circ$

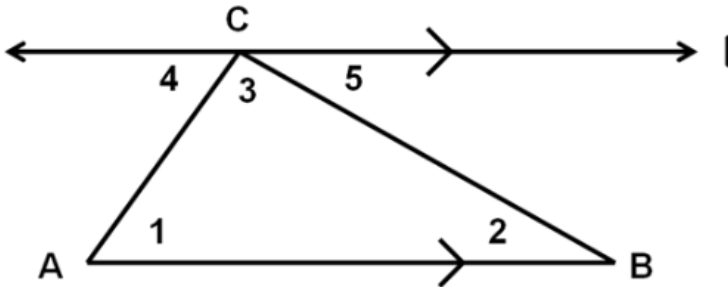

Statements	Reason
1. $m\angle 4 = m\angle 1$	1. <i>Alternate Interior Angles Theorem</i>
2. $m\angle 5 = m\angle 2$	2. <i>Alternative Interior Angles Theorem</i>
3. $m\angle 4 + m\angle 3 + m\angle 5 = 180^\circ$	3. Three angles form one side of the straight line
4. $m\angle 1 + m\angle 3 + m\angle 2 = 180^\circ$	4. <i>Substitution</i>

Isosceles Triangles

Theorem: If two sides of a triangle are congruent, then the angles opposite those sides are congruent.

Fill in the following proof using postulates, theorems, and properties that you have learned.

Proof:

Given: $\overline{AC} \cong \overline{AB}$

Prove: $\angle C \cong \angle B$

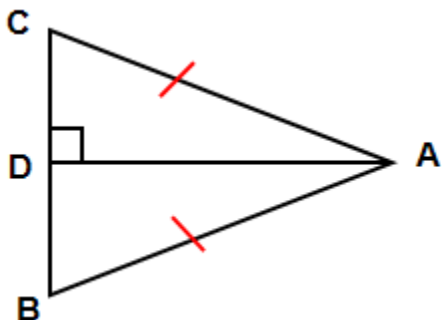

Statements	Reason
1. $\overline{AC} \cong \overline{AB}$	1. Given
2. Draw $\overline{AD} \perp \overline{CB}$	2. <i>By Euclid's Perpendicular Postulate</i>
3. $\overline{AD} \cong \overline{AD}$	3. Reflexive Property of Congruence
4. $\triangle CDA \cong \triangle BDA$	4. <i>Hypotenuse Leg Postulate</i>
5. $\angle C \cong \angle B$	5. <i>CPCTC</i>

Definition: A line segment whose endpoints are the midpoint of two sides of a triangle is called a midsegment of the triangle.

Theorem: The segment connecting the midpoints of two sides of the triangle is parallel to the third side and half the length of the third side.

In the figure below $\overline{XY} \parallel \overline{AB}$ and $XY = \frac{1}{2}(AB)$ or $AB = 2(XY)$

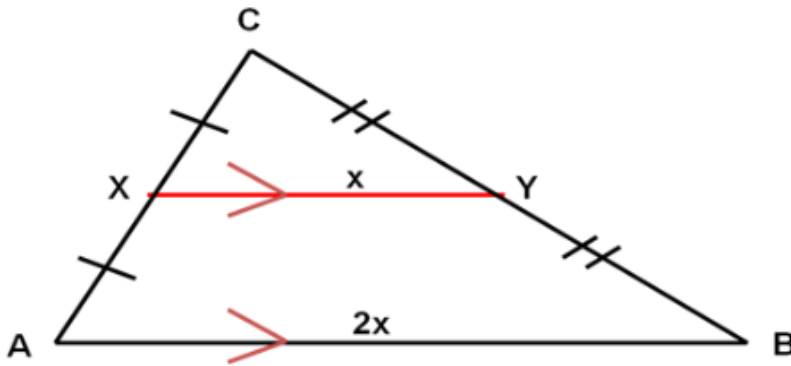

Let's prove this theorem using a sheet of patty paper.

- 1) Draw $\triangle ABC$ on a sheet of patty paper.
- 2) Fold and pinch to locate the three midpoints of the triangle.
- 3) Draw and label the three midpoints X, Y, Z.
- 4) Draw segments \overline{XY} , \overline{YZ} , and \overline{XZ} .

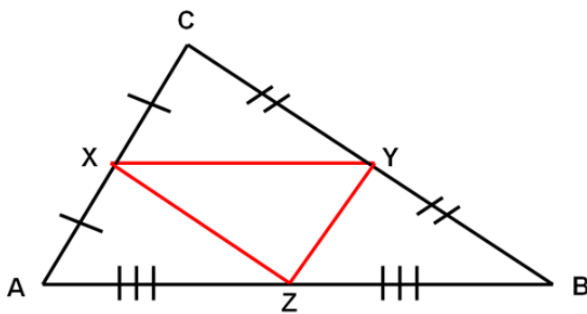

Using your construction, verify:

$$\overline{XY} \parallel \overline{AB}, \overline{YZ} \parallel \overline{AC}, \text{ and } \overline{XZ} \parallel \overline{BC}$$

Notice:

$$\triangle AXZ \cong \triangle XCY \cong \triangle ZYB \cong \triangle YZX$$

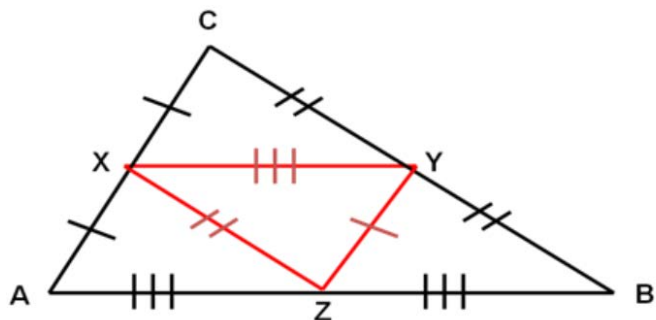

Triangle Proofs

Mathematical Goals

- Prove theorems pertaining to triangles.

STANDARDS ADDRESSED IN THIS TASK

MGSE9-12.G.CO.10 Prove theorems about triangles. Theorems include: measures of interior angles of a triangle sum to 180 degrees; base angles of isosceles triangles are congruent; the segment joining midpoints of two sides of a triangle is parallel to the third side and half the length; the medians of a triangle meet at a point.

Standards for Mathematical Practice

- 1. Make sense of problems and persevere in solving them** by requiring students to interpret and make meaning of a problem and find a logical starting point, and to monitor their progress and change their approach to solving the problem, if necessary.
- 2. Reason abstractly and quantitatively** by requiring students to make sense of quantities and their relationships to one another in problem situations.
- 3. Construct viable arguments and critique the reasoning of others** by engaging students on discussion of why they agree or disagree with responses, decide whether they make sense, and ask useful questions to clarify or improve the arguments.
- 4. Model with mathematics** by expecting students to apply the mathematics concepts they know in order to solve problems arising in everyday situations, and reflect on whether the results are sensible for the given scenario.
- 5. Use appropriate tools strategically** by expecting students to consider available tools when solving a mathematical problem. These tools might include pencil and paper, concrete models, a ruler, a protractor, a compass, a calculator, software, etc.
- 6. Attend to precision** by requiring students to calculate efficiently and accurately; and to communicate precisely with others by using clear mathematical language to discuss their reasoning.
- 7. Look for and make use of structure** by expecting students to apply rules, look for patterns and analyze structure.
- 8. Look for and express regularity in repeated reasoning** by expecting students to understand broader applications and look for structure and general methods in similar situations.

Introduction

This task provides students an opportunity to prove several triangles theorems including the measure of interior angles of a triangle sum to 180 degrees, base angles of isosceles triangles are congruent, and the segment joining midpoints of two sides of a triangle is parallel to the third side and half the length. Students will review CPCTC (Corresponding Parts of Congruent Triangles are Congruent) before beginning the proofs. Encourage multiple ways of writing

proofs, such as in narrative paragraphs, using flow diagrams, in two-column format, and using diagrams without words.

Materials

- Patty paper

Corresponding
 Parts of
 Congruent
 Triangles are
 Congruent

Remember the definition of congruent figures?

If two geometric figures are congruent, then their corresponding parts are congruent.

Example: In the figure below, how do we know that $\triangle ABC \cong \triangle DBC$?

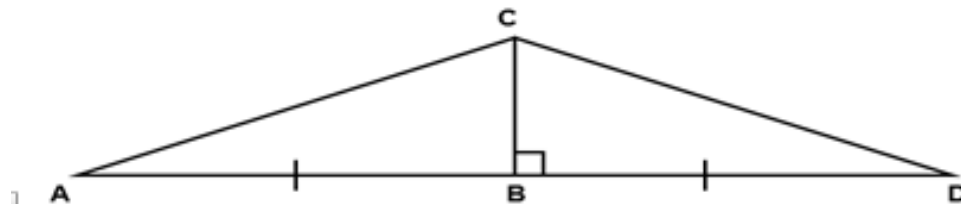

Statements	Reason
1. $\overline{AB} \cong \overline{BD}$	1. Given
2. $\angle ABC \cong \angle DBC$	2. By Euclid's Perpendicular Postulate
3. $\overline{CB} \cong \overline{CB}$	3. Reflexive Property of Congruence
4. $\triangle ABC \cong \triangle DBC$	4. SAS Postulate

... And now that we know that the two triangles are congruent then by CPCTC all the other corresponding parts are congruent as well.

$$\begin{aligned} \angle A &\cong \angle D \\ \angle ACB &\cong \angle DCB \\ \overline{AC} &\cong \overline{DC} \end{aligned}$$

Let's start proving theorems about triangles using two column proofs. Fill in the missing statements and reasons in the proof below.

Georgia Department of Education
 Georgia Standards of Excellence Framework
GSE Geometry • Unit 2

Theorem: The sum of the measure of the angles of any triangle is 180° .

Proof:

Given: The top line (that touches the top of the triangle) is parallel to the base of the triangle.

Prove: $m\angle 1 + m\angle 3 + m\angle 2 = 180^\circ$

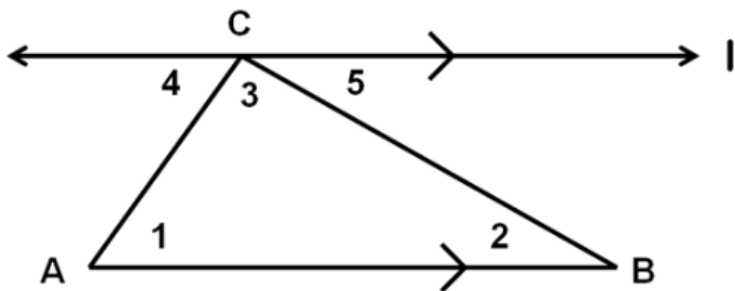

Statements	Reason
1. $m\angle 4 = m\angle 1$	1.
2. $m\angle 5 = m\angle 2$	2.
3.	3. Three angles form one side of the straight line
4. $m\angle 1 + m\angle 3 + m\angle 2 = 180^\circ$	4.

Isosceles Triangles

Theorem: If two sides of a triangle are congruent, then the angles opposite those sides are congruent.

Fill in the following proof using postulates, theorems, and properties that you have learned.

Proof:

Given: $\overline{AC} \cong \overline{AB}$

Prove: $\angle C \cong \angle B$

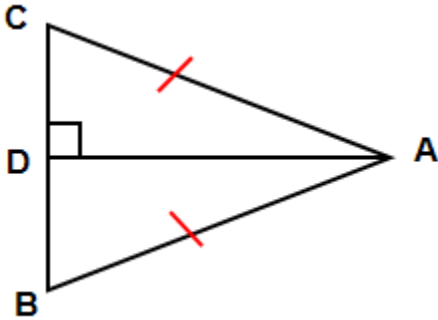

Statements	Reason
1.	1. Given
2. Draw $\overline{AD} \perp \overline{CB}$	2.
3.	3. Reflexive Property of Congruence
4. $\triangle CDA \cong \triangle BDA$	4.
5.	5.

Definition: A line segment whose endpoints are the midpoint of two sides of a triangle is called a midsegment of the triangle.

Theorem: The segment connecting the midpoints of two sides of the triangle is parallel to the third side and half the length of the third side.

In the figure below $\overline{XY} \parallel \overline{AB}$ and $XY = \frac{1}{2}(AB)$ or $AB = 2(XY)$

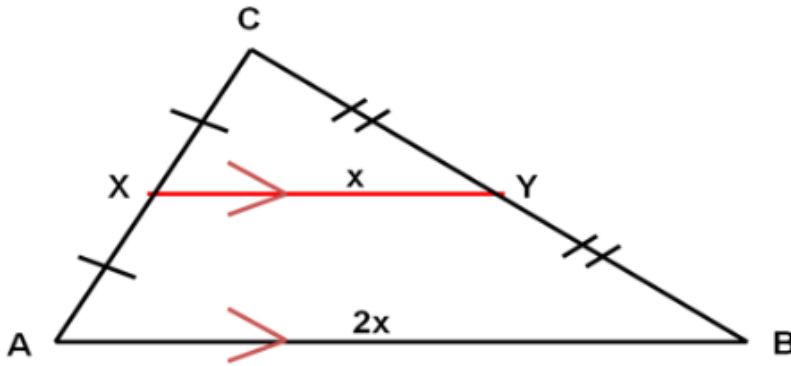

Let's prove this theorem using a sheet of patty paper.

- 1) Draw $\triangle ABC$ on a sheet of patty paper.
- 2) Fold and pinch to locate the three midpoints of the triangle.
- 3) Draw and label the three midpoints X, Y, Z.
- 4) Draw segments \overline{XY} , \overline{YZ} , and \overline{XZ} .

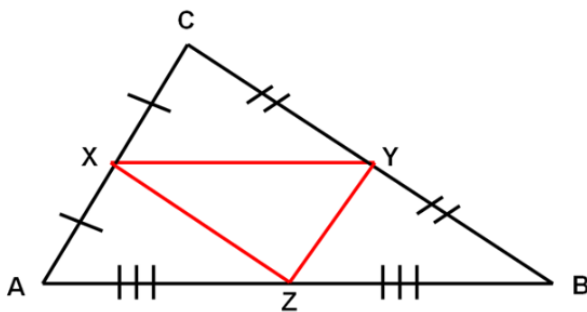

Using your construction, verify:

$$\overline{XY} \parallel \overline{AB}, \overline{YZ} \parallel \overline{XY}, \overline{CA}, \text{ and } \overline{XZ} \parallel \overline{CB}$$

Lunch Lines

Mathematical Goals

- Prove vertical angles are congruent.
- Understand when a transversal is drawn through parallel lines, special angles relationships occur.
- Prove when a transversal crosses parallel lines, alternate interior angles are congruent and corresponding angles are congruent.

STANDARDS ADDRESSED IN THIS TASK

MGSE9-12.G.CO.9 Prove theorems about lines and angles. Theorems include: vertical angles are congruent; when a transversal crosses parallel lines, alternate interior angles are congruent and corresponding angles are congruent; points on a perpendicular bisector of a line segment are exactly those equidistant from the segment's endpoints.

Standards for Mathematical Practice

1. **Make sense of problems and persevere in solving them** by requiring students to interpret and make meaning of a problem and find a logical starting point, and to monitor their progress and change their approach to solving the problem, if necessary.
2. **Reason abstractly and quantitatively** by requiring students to make sense of quantities and their relationships to one another in problem situations.
3. **Construct viable arguments and critique the reasoning of others** by engaging students on discussion of why they agree or disagree with responses, decide whether they make sense, and ask useful questions to clarify or improve the arguments.
4. **Model with mathematics** by expecting students to apply the mathematics concepts they know in order to solve problems arising in everyday situations, and reflect on whether the results are sensible for the given scenario.
5. **Use appropriate tools strategically** by expecting students to consider available tools when solving a mathematical problem. These tools might include pencil and paper, concrete models, a ruler, a protractor, a compass, a calculator, software, etc.
6. **Attend to precision** by requiring students to calculate efficiently and accurately; and to communicate precisely with others by using clear mathematical language to discuss their reasoning.

Common Student Misconceptions

Research over the last four decades suggests that student misconceptions about proof abound:

1. Even after proving a generalization, students believe that exceptions to the generalization might exist;
2. One counterexample is not sufficient;
3. The converse of a statement is true (parallel lines do not intersect, lines that do not intersect are parallel; and

4. A conjecture is true because it worked in all examples that were explored.

Each of these misconceptions needs to be addressed, both by the ways in which formal proof is taught in geometry and how ideas about “justification” are developed throughout a student’s mathematical education

Introduction

This task is designed to reinforce student understanding of angle relationships when lines intersect and when a transversal crosses parallel lines. Using geometric properties of intersecting and parallel lines to establish and reinforce algebraic relationships is an almost limitless and rich source of problems for student practice and connections between mathematical concepts. Students first need to prove several theorems about lines and angles before beginning the task.

Two angles are vertical angles if their sides form two pairs of opposite rays.

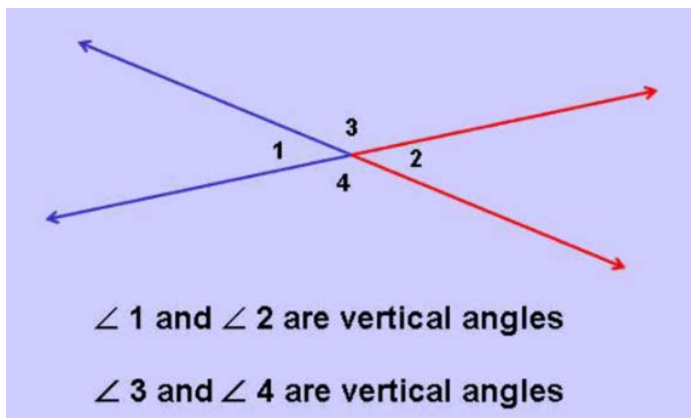

How do you know that vertical angles are congruent?

$m\angle 1 + m\angle 3 = 180^\circ$ because the Linear Pair postulate

$m\angle 2 + m\angle 3 = 180^\circ$ because the Linear Pair postulate

Set the two equations equal to each other since they both equal 180 degrees.

$$m\angle 2 + m\angle 3 = m\angle 1 + m\angle 3$$

$$\begin{array}{r} -m\angle 3 \\ m\angle 2 \end{array} = \begin{array}{r} -m\angle 3 \\ m\angle 1 \end{array}$$

Therefore: $\angle 2 \cong \angle 1$

Prove that $\angle 3 \cong \angle 4$ using a similar method.

When a transversal crosses parallel lines, there are several pairs of special angles. Let's look at a few together.

Corresponding Angle Postulate: If two parallel lines are cut by a transversal, then corresponding angles are congruent.

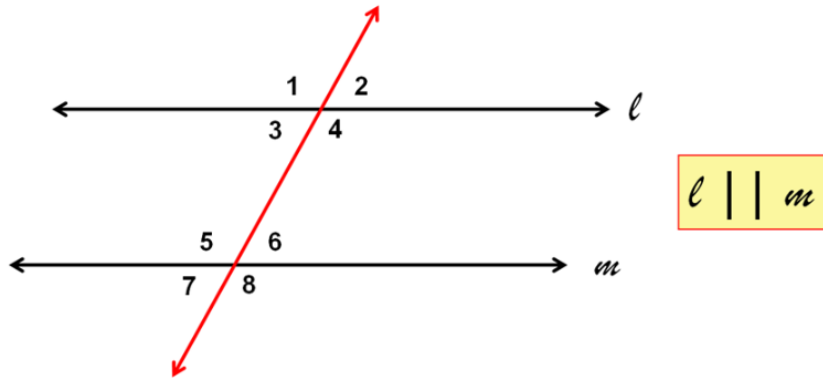

Using this postulate, name a pair of congruent angles.

How do we know that $\angle 3 \cong \angle 6$?

Alternate Interior Angle Theorem: If two parallel lines are cut by a transversal, then alternate interior angles are congruent.

Prove this theorem using the figure above.

Teacher Notes

Proof: Alternate Interior Angles are Congruent
 $\angle 3 \cong \angle 7$ by *Corresponding Angles Postulate*
 $\angle 7 \cong \angle 6$ by *Vertical Angles are Congruent*
 $\angle 3 \cong \angle 6$ by *Substitution*

How do we know that $\angle 3 \cong \angle 5$ are supplementary?

Same-Side Interior Angle Theorem: If two parallel lines are cut by a transversal, then same-side interior angles are supplementary.

Prove this theorem using the figure above.

Proof: Same-Side Interior Angles are Supplementary
 $m\angle 3 + m\angle 1 = 180^\circ$ by *Linear Pair Postulate*
 $m\angle 1 = m\angle 5$ by *Corresponding Angles Postulate*

$m\angle 3 + m\angle 5 = 180^\circ$ by Substitution.

Paul, Jane, Justin, and Opal were finished with lunch and began playing with drink straws.

Each one was making a line design using either 3 or 4 straws.

They had just come from math class where they had been studying special angles.

Paul pulled his pencil out of his book bag and labeled some of the angles and lines. He then challenged himself and the others to find all the labeled angle measurements in Paul and Justin's straw designs and to determine whether the lines that appear to be parallel really are parallel.

Paul's straw design

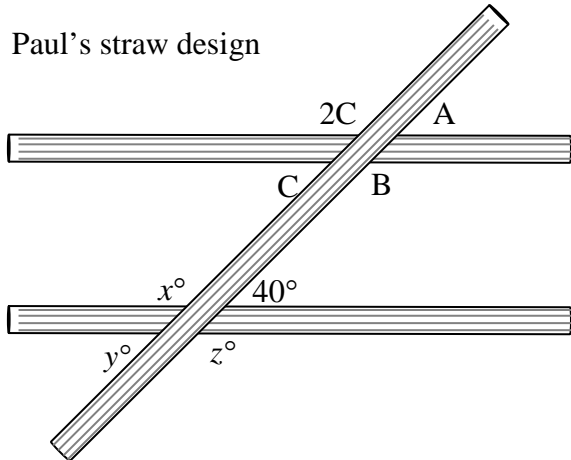

- Find all of the labeled angle measurements.
- Determine whether the lines that appear to be parallel really are parallel.
- Explain the reasoning for your results.

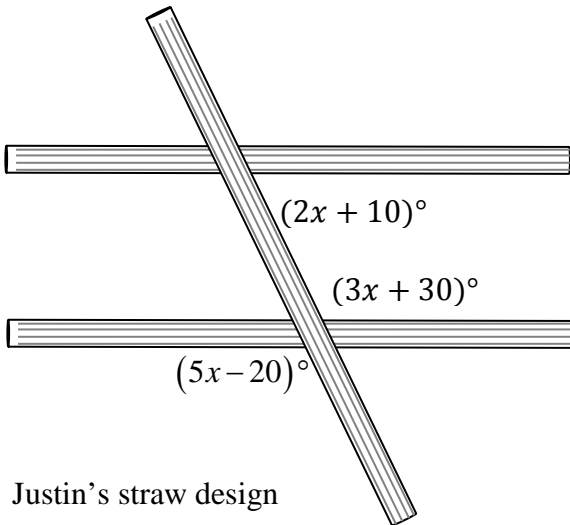

Justin's straw design

Paul then challenged himself and the others to find all the labeled angle measurements in Jane and Opal’s straw designs knowing that the lines created by the straws in their designs were parallel.

Jane’s straw design

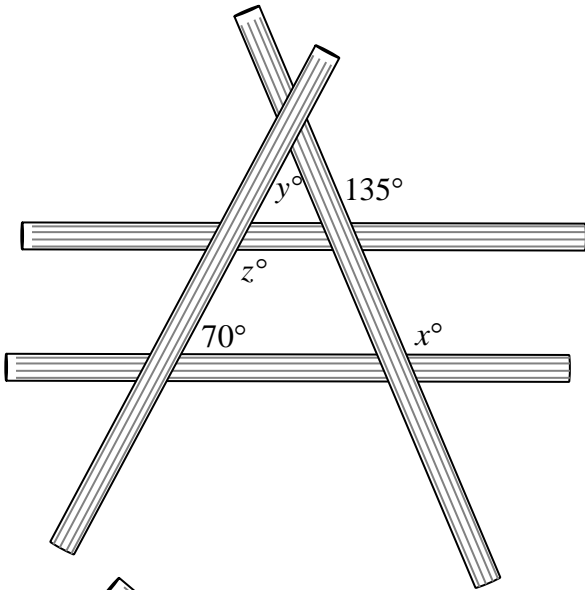

- Find all of the labeled angle measurements (knowing that the lines created by the straws are parallel).
- Explain the reasoning for your results

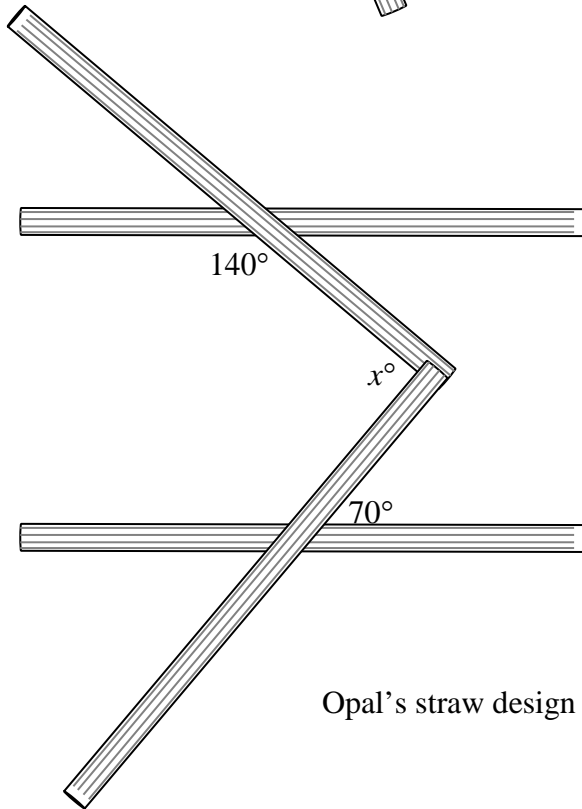

Opal’s straw design

Solutions

Paul's straw design:

This relies entirely on vertical angles and linear pairs. $m\angle x = m\angle z = 140^\circ$; $m\angle y = 40^\circ$. Use the linear pair relationship for the angles involving C to conclude $m\angle A = m\angle C = 40^\circ$; $m\angle B \neq m\angle 2C$; $m\angle C + m\angle 2C \neq 180^\circ$. Therefore, lines m and n are not parallel because corresponding angles do not have the same measure. NOTE: The argument could also be made because neither alternate interior nor alternate exterior angles are congruent. Also, neither same-side interior nor exterior angles are supplementary.

Justin's straw design:

Vertical angles give $5x - 20 = 3x + 30$

$$\begin{array}{r} \underline{-3x} \qquad \underline{-3x} \\ 2x - 20 = 30 \\ \underline{+20} \quad \underline{+20} \\ 2x = 50 \\ 2x \div 2 = 50 \div 2 \\ x = 25 \end{array}$$

If the lines are parallel, then the same-side interior angles must have a sum of 180° .

$$\begin{aligned} \text{By substitution, } (2x + 10) + (3x + 30) &= (2 \cdot 25 + 10) + (3 \cdot 25 + 30) \\ &= (50 + 10) + (75 + 30) \\ &= 60 + 105 \\ &\neq 180 \end{aligned}$$

Since these measures are not supplementary, the lines are not parallel.

Jane's straw design:

Use corresponding, same-side interior, and vertical angles; linear pairs; and the sum of the angles in a triangle.

$$m\angle x = 135^\circ, m\angle z = 70^\circ, m\angle y = 65^\circ$$

Opal's straw design:

Extending either of the partial transversals and using linear pairs and alternate interior angles gives angle measures of 40° and 70° inside a triangle. Therefore, $m\angle x = 110^\circ$.

Examples of thinking are shown below.

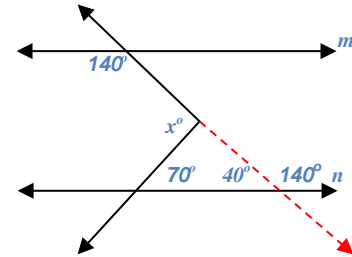
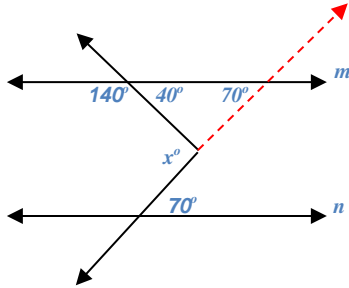

$$40 + 70 + (180 - x) = 180$$

Once the students have mastered these ideas, it would be good for them to be challenged with similar problems that do not have nice, neat, whole number solutions. They should feel comfortable with rational number solutions that are both positive and negative.

Lunch Lines

Mathematical Goals

- Prove vertical angles are congruent.
- Understand when a transversal is drawn through parallel lines, special angles relationships occur.
- Prove when a transversal crosses parallel lines, alternate interior angles are congruent and corresponding angles are congruent.

STANDARDS ADDRESSED IN THIS TASK

MGSE9-12.G.CO.9 Prove theorems about lines and angles. Theorems include: vertical angles are congruent; when a transversal crosses parallel lines, alternate interior angles are congruent and corresponding angles are congruent; points on a perpendicular bisector of a line segment are exactly those equidistant from the segment's endpoints.

Standards for Mathematical Practice

- 1. Make sense of problems and persevere in solving them** by requiring students to interpret and make meaning of a problem and find a logical starting point, and to monitor their progress and change their approach to solving the problem, if necessary.
- 2. Reason abstractly and quantitatively** by requiring students to make sense of quantities and their relationships to one another in problem situations.
- 3. Construct viable arguments and critique the reasoning of others** by engaging students on discussion of why they agree or disagree with responses, decide whether they make sense, and ask useful questions to clarify or improve the arguments.
- 4. Model with mathematics** by expecting students to apply the mathematics concepts they know in order to solve problems arising in everyday situations, and reflect on whether the results are sensible for the given scenario.
- 5. Use appropriate tools strategically** by expecting students to consider available tools when solving a mathematical problem. These tools might include pencil and paper, concrete models, a ruler, a protractor, a compass, a calculator, software, etc.
- 6. Attend to precision** by requiring students to calculate efficiently and accurately; and to communicate precisely with others by using clear mathematical language to discuss their reasoning.

Two angles are vertical angles if their sides form two pairs of opposite rays.

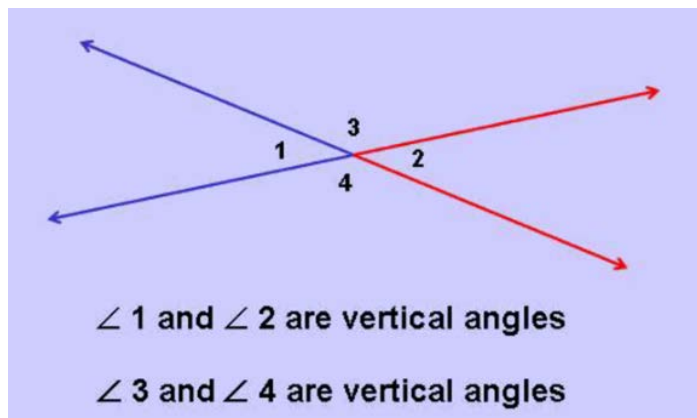

How do you know that vertical angles are congruent?

$m\angle 1 + m\angle 3 = 180^\circ$ because the Linear Pair postulate

$m\angle 2 + m\angle 3 = 180^\circ$ because the Linear Pair postulate

Set the two equations equal to each other since they both equal 180 degrees.

$$\begin{aligned} m\angle 2 + m\angle 3 &= m\angle 1 + m\angle 3 \\ -m\angle 3 &\quad -m\angle 3 \\ m\angle 2 &= m\angle 1 \end{aligned}$$

Therefore: $\angle 2 \cong \angle 1$

Prove that $\angle 3 \cong \angle 4$ using a similar method.

When a transversal crosses parallel lines, there are several pairs of special angles. Let's look at a few together.

Corresponding Angle Postulate: If two parallel lines are cut by a transversal, then corresponding angles are congruent.

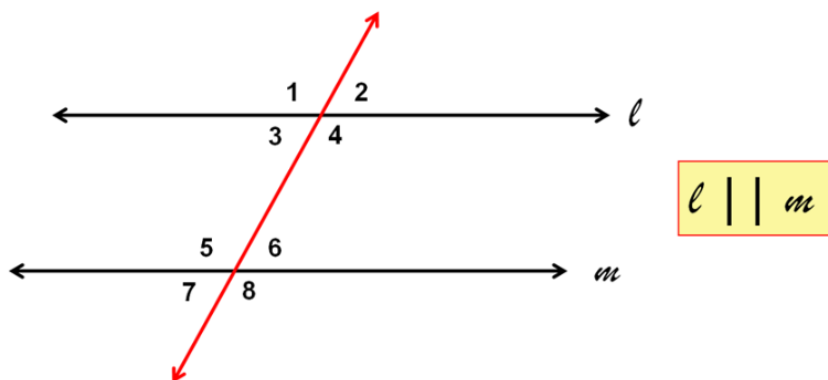

Using this postulate, name a pair of congruent angles.

How do we know that $\angle 3 \cong \angle 6$?

Alternate Interior Angle Theorem: If two parallel lines are cut by a transversal, then alternate interior angles are congruent.

Prove this theorem using the figure above.

How do we know that $\angle 3 \cong \angle 5$ are supplementary?

Same-Side Interior Angle Theorem: If two parallel lines are cut by a transversal, then same-side interior angles are supplementary.

Prove this theorem using the figure above.

Paul, Jane, Justin, and Opal were finished with lunch and began playing with drink straws. Each one was making a line design using either 3 or 4 straws. They had just come from math class where they had been studying special angles. Paul pulled his pencil out of his book bag and labeled some of the angles and lines. He then challenged himself and the others to find all the labeled angle measurements in Paul and Justin's straw designs and to determine whether the lines that appear to be parallel really are parallel.

Paul's straw design

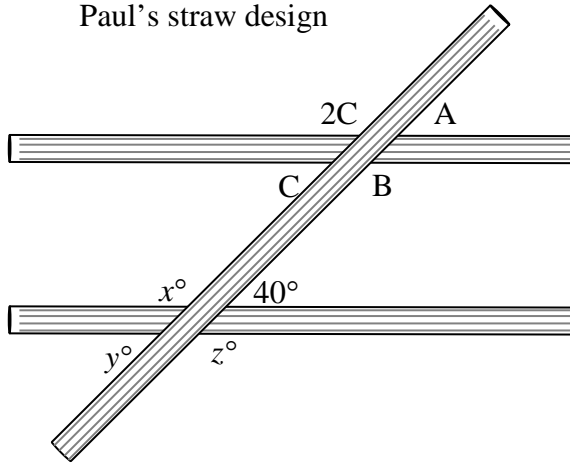

- Find all of the labeled angle measurements.
- Determine whether the lines that appear to be parallel really are parallel.
- Explain the reasoning for your results.

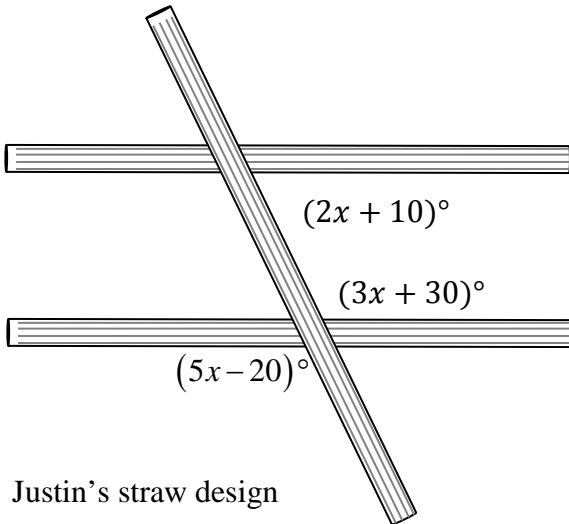

Justin's straw design

Paul then challenged himself and the others to find all the labeled angle measurements in Jane and Opal’s straw designs knowing that the lines created by the straws in their designs were parallel.

Jane’s straw design

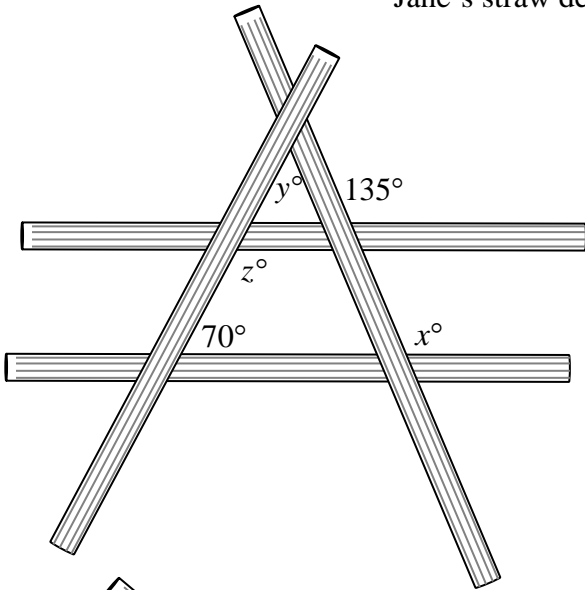

- Find all of the labeled angle measurements (knowing that the lines created by the straws are parallel).
- Explain the reasoning for your results

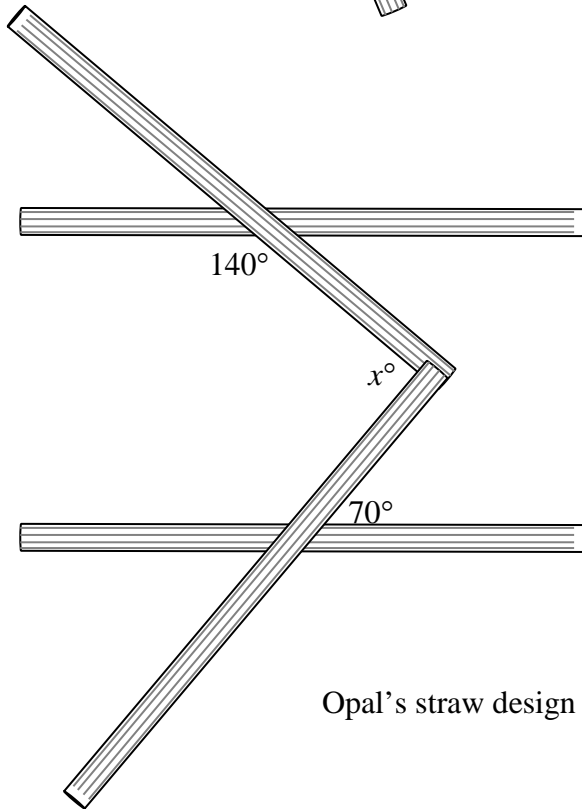

Opal’s straw design

Triangle Proportionality Theorem

Mathematical Goals

- Prove a line parallel to one side of a triangle divides the other two proportionally, and it's converse.

STANDARDS ADDRESSED IN THIS TASK

MGSE9-12.G.SRT.2 Given two figures, use the definition of similarity in terms of similarity transformations to decide if they are similar; explain, using similarity transformations, the meaning of similarity for triangles as the equality of all corresponding pairs of angles and the proportionality of all corresponding pairs of sides.

MGSE9-12.G.SRT.3 Use the properties of similarity transformations to establish the AA criterion for two triangles to be similar.

MGSE9-12.G.SRT.4 Prove theorems about triangles. Theorems include: a line parallel to one side of a triangle divides the other two proportionally, (and its converse); the Pythagorean Theorem using triangle similarity.

MGSE9-12.G.SRT.5 Use congruence and similarity criteria for triangles to solve problems and to prove relationships in geometric figures.

Standards for Mathematical Practice

1. **Make sense of problems and persevere in solving them** by requiring students to interpret and make meaning of a problem and find a logical starting point, and to monitor their progress and change their approach to solving the problem, if necessary.
2. **Reason abstractly and quantitatively** by requiring students to make sense of quantities and their relationships to one another in problem situations.
3. **Construct viable arguments and critique the reasoning of others** by engaging students on discussion of why they agree or disagree with responses, decide whether they make sense, and ask useful questions to clarify or improve the arguments.
4. **Model with mathematics** by expecting students to apply the mathematics concepts they know in order to solve problems arising in everyday situations, and reflect on whether the results are sensible for the given scenario.
5. **Use appropriate tools strategically** by expecting students to consider available tools when solving a mathematical problem. These tools might include pencil and paper, concrete models, a ruler, a protractor, a compass, a calculator, software, etc.
6. **Attend to precision** by requiring students to calculate efficiently and accurately; and to communicate precisely with others by using clear mathematical language to discuss their reasoning.
7. **Look for and make use of structure** by expecting students to apply rules, look for patterns and analyze structure.

8. **Look for and express regularity in repeated reasoning** by expecting students to understand broader applications and look for structure and general methods in similar situations.

Common Student Misconceptions

Research over the last four decades suggests that student misconceptions about proof abound:

1. Even after proving a generalization, students believe that exceptions to the generalization might exist;
2. One counterexample is not sufficient;
3. The converse of a statement is true (parallel lines do not intersect, lines that do not intersect are parallel; and
4. A conjecture is true because it worked in all examples that were explored.

Each of these misconceptions needs to be addressed, both by the ways in which formal proof is taught in geometry and how ideas about “justification” are developed throughout a student’s mathematical education

Introduction

The activity that follows will help students discover another result that emerges from parallel lines crossed by transversals. The relationship that students will notice is that if a line is parallel to one side of a triangle and intersects the other two sides, then it divides those sides proportionally. This relationship is formally known as the Side-Splitter Theorem. It is also referred to as the Triangle Proportionality Theorem. This task includes two different ways to prove these theorems. The first method requires a Dynamic Geometric Software and the second method involves using a two-column proof.

Materials

- colored pencils
- Dynamic Geometry Software

Allow students to use a Dynamic Geometry Software (DGS) package to draw two parallel lines, A and B.

The result should look similar to Figure 1.

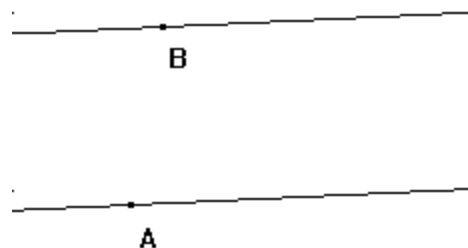

Figure 1

Then have them draw line \overline{AB} . Now have the students create a new point C on \overline{AB} and draw another transversal. Label the intersections of this line with the parallel lines as points D and E as shown in Figure 2.

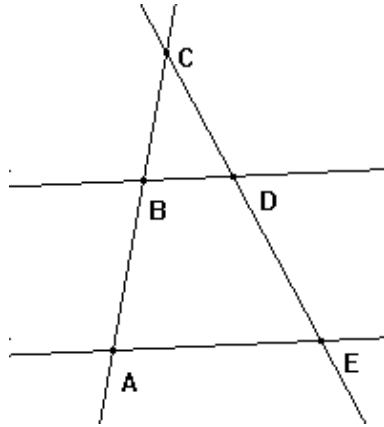

Figure 2

Ask the students to describe what they see.
 Be sure that they see two triangles:
 $\triangle CBD$ and $\triangle CAE$.

Note: Students may benefit from using colored pencils to see both triangle $\triangle CBD$ and $\triangle CAE$.

Now have students:

- use the DGS to measure the sides of the two triangles and their perimeters.
- record these values in the first two rows of the table below.
- use the DGS to compute the value of the ratio of the Side 1 measurements, Side 2 measurements, etc. Store each ratio computation on the DGS construction for use in a later question.

	Side 1	Side 2	Side 3	Perimeter
$\triangle CBD$	$CB =$	$CD =$	$BD =$	$Perim_{\triangle CBD} =$
$\triangle CAE$	$CA =$	$CE =$	$AE =$	$Perim_{\triangle CAE} =$
Ratio	$\frac{CB}{CA} =$	$\frac{CD}{CE} =$	$\frac{BD}{AE} =$	$\frac{Perim_{\triangle CBD}}{Perim_{\triangle CAE}} =$

The following questions could be addressed during the course of the activity:

1. Explain why \overline{AB} (illustrated in figure 2) is a transversal?

Solution

Since \overline{AB} intersects two other lines, it is a transversal.

2. Explain why segments \overline{CB} and \overline{CA} are called corresponding segments?

Solution

Students already know what corresponding angles are and will be able to transfer this knowledge to this question. The two segments are in the same relative position in their respective figures, just like corresponding angles are in the same relative position in their respective intersections.

3. In view of the last row of results in the table, what appears to be true about the ratio of lengths defined by two transversals intersecting parallel lines?

Solution

While the side lengths and ratios will vary from student to student and drawing to drawing, all four of the ratios will be constant at any one instant.

4. Grab different points and lines in the construction and move them around, if possible.

Solution

Not all points or lines will move due to the way they were constructed. While all of the measurements will change, one relationship will continue to hold no matter how the construction is changed. What is that relationship? Same answer as question 3.

5. Allow students to compare their findings from question 4 to those of a classmate. Did everyone discover the same relationship?

Solution

All students should notice that the sides and ratios change, but the ratios in any one drawing at any one instant are always equal.

6. Ask students to use the relationship that they have observed to solve for the unknown quantities in each of the following figures. They may assume that lines which look parallel in each figure are parallel.

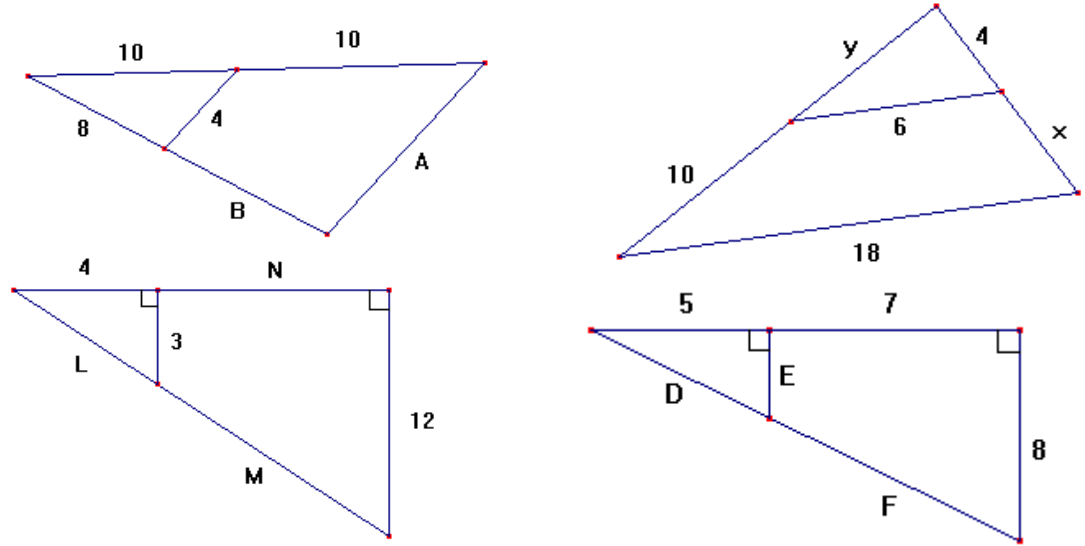

Solution

Students should be able to set up proportionality ratios to get the following values. The last triangle is definitely more challenging because of the numbers, but uses exactly the same ideas as the others.

$$A = B = 8; \quad x = 8 \text{ and } y = 5; \quad L = 5, \quad M = 15, \text{ and } N = 12; \quad \text{and}$$

$$D = \frac{5}{3}\sqrt{13} \approx 6.009, \quad E = \frac{10}{3}, \text{ and } F = \frac{7}{3}\sqrt{13} \approx 8.413.$$

Notice that the last two triangles also require the use of the Pythagorean Theorem. This additional fact allows students to take different approaches to finding the unknown quantities. The teacher could use this opportunity to explain why

- *knowing one Pythagorean Triple automatically gives all similar triples, and*
- *aligning similar right triangles so that their right angles coincide guarantees that their hypotenuses will be parallel*

Some additional simple online demonstrations and problems relating to this are located on the following websites:

<http://www.mathwarehouse.com/geometry/similar/triangles/side-splitter-theorem.php>
<http://www.mathwarehouse.com/geometry/similar/triangles/>

Triangle Proportionality Theorem

If a line parallel to one side of a triangle intersects the other two sides, then it divides the two sides proportionally.

Solutions

Proof #1:

Given: $\overleftrightarrow{EF} \parallel \overleftrightarrow{BC}$

Prove: $\frac{AE}{EB} = \frac{AF}{FC}$

Complete the proof:

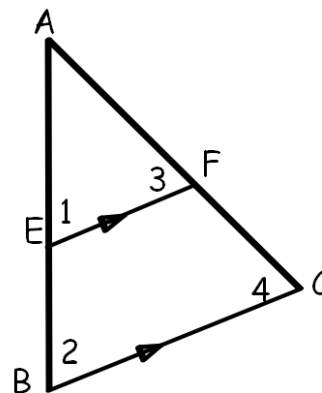

Show that $\triangle AEF \sim \triangle ABC$

Since $\overleftrightarrow{EF} \parallel \overleftrightarrow{BC}$, you can conclude that $\angle 1 \cong \angle 2$ and $\angle 3 \cong \angle 4$ by *Corresponding Angle Postulate*

So $\triangle AEF \sim \triangle ABC$ by *AA~*

Use the fact that corresponding sides of similar triangles are proportional to complete the proof

$$\frac{AB}{AE} = \frac{AC}{AF} \text{ Corresponding sides are proportional}$$

$$\frac{AE+EB}{AE} = \frac{AF+AC}{AF} \text{ Segment Addition Postulate}$$

$$1 + \frac{EB}{AE} = 1 + \frac{AC}{AF} \text{ Use the property that } \frac{a+b}{c} = \frac{a}{c} + \frac{b}{c}$$

$$\frac{EB}{AE} = \frac{AC}{AF} \text{ Subtract 1 from both sides.}$$

$$\frac{AE}{EB} = \frac{AF}{FC} \text{ Take the reciprocal of both sides.}$$

Converse of the Triangle Proportionality Theorem

If a line divides two sides of a triangle proportionally, then it is parallel to the third side

Proof #2

Given: $\frac{AE}{EB} = \frac{AF}{FC}$

Prove: $\overleftrightarrow{EF} \parallel \overleftrightarrow{BC}$

Complete the proof. Show that $\triangle AEF \sim \triangle ABC$

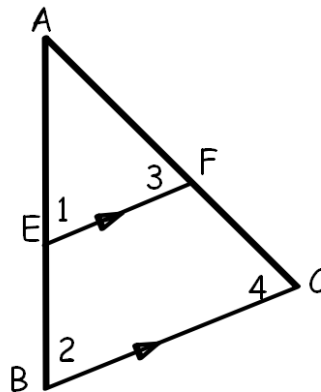

It is given that $\frac{AE}{EB} = \frac{AF}{FC}$ and taking the reciprocal of both sides show that $\frac{EB}{AE} = \frac{FC}{AF}$.

Now add 1 to both sides by adding $\frac{AE}{AE}$ to the left side and $\frac{AF}{AF}$ to the right side.

$$\frac{EB}{AE} + \frac{AE}{AE} = \frac{FC}{AF} + \frac{AF}{AF}$$

Adding and using the Segment Addition Postulate gives $\frac{EB+AE}{AE} = \frac{FC+AF}{AF}$.

Since $\angle A \cong \angle A$, $\triangle AEF \sim \triangle ABC$ by **SAS~**

As corresponding angles of similar triangles, $\angle AEF \cong \angle EBC$

So, $\overleftrightarrow{EF} \parallel \overleftrightarrow{BC}$ by the **Converse of the Corresponding Angles Postulate**

Let's practice finding the length of a segment since you know how to prove the Triangle Proportionality Theorem and its converse.

1. What is the length of NR?

$$\frac{9}{NR} = \frac{6}{4}$$

$$6(NR) = 9(4)$$

$$6(NR) = 36$$

$$NR = 4$$

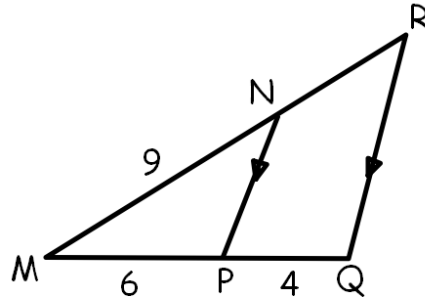

2. What is the length of DF?

$$\frac{12}{8} = \frac{DF}{6}$$

$$8(DF) = 72$$

$$DF = 9$$

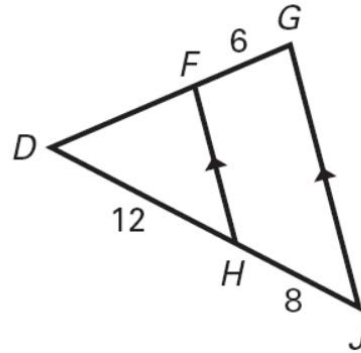

3. Given the diagram, determine whether \overline{MN} is parallel to \overline{PQ} .

Students need to determine whether $\frac{PR}{PM} = \frac{RQ}{QN}$

$\frac{54}{42} = \frac{48}{36}$, $\frac{9}{7} = \frac{4}{3}$; Therefore \overline{MN} is not parallel to \overline{PQ} since the ratios are not equal.

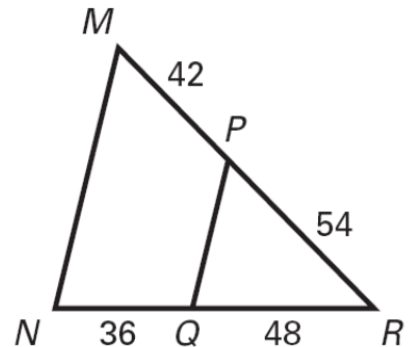

Triangle Proportionality Theorem

Mathematical Goals

- Prove a line parallel to one side of a triangle divides the other two proportionally, and it's converse.

STANDARDS ADDRESSED IN THIS TASK

MGSE9-12.G.SRT.2 Given two figures, use the definition of similarity in terms of similarity transformations to decide if they are similar; explain, using similarity transformations, the meaning of similarity for triangles as the equality of all corresponding pairs of angles and the proportionality of all corresponding pairs of sides.

MGSE9-12.G.SRT.3 Use the properties of similarity transformations to establish the AA criterion for two triangles to be similar.

MGSE9-12.G.SRT.4 Prove theorems about triangles. Theorems include: a line parallel to one side of a triangle divides the other two proportionally, (and its converse); the Pythagorean Theorem using triangle similarity.

MGSE9-12.G.SRT.5 Use congruence and similarity criteria for triangles to solve problems and to prove relationships in geometric figures.

Standards for Mathematical Practice

- 1. Make sense of problems and persevere in solving them** by requiring students to interpret and make meaning of a problem and find a logical starting point, and to monitor their progress and change their approach to solving the problem, if necessary.
- 2. Reason abstractly and quantitatively** by requiring students to make sense of quantities and their relationships to one another in problem situations.
- 3. Construct viable arguments and critique the reasoning of others** by engaging students on discussion of why they agree or disagree with responses, decide whether they make sense, and ask useful questions to clarify or improve the arguments.
- 4. Model with mathematics** by expecting students to apply the mathematics concepts they know in order to solve problems arising in everyday situations, and reflect on whether the results are sensible for the given scenario.
- 5. Use appropriate tools strategically** by expecting students to consider available tools when solving a mathematical problem. These tools might include pencil and paper, concrete models, a ruler, a protractor, a compass, a calculator, software, etc.
- 6. Attend to precision** by requiring students to calculate efficiently and accurately; and to communicate precisely with others by using clear mathematical language to discuss their reasoning.
- 7. Look for and make use of structure** by expecting students to apply rules, look for patterns and analyze structure.

8. **Look for and express regularity in repeated reasoning** by expecting students to understand broader applications and look for structure and general methods in similar situations.

Draw two parallel lines that contain points A and B. (Refer to Figure 1.)

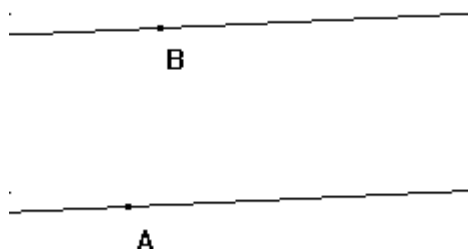

Figure 1

Draw line \overline{AB} . Create a new point C on \overline{AB} and draw another transversal. Label the intersections of this line with the parallel lines as points D and E as shown in Figure 2.

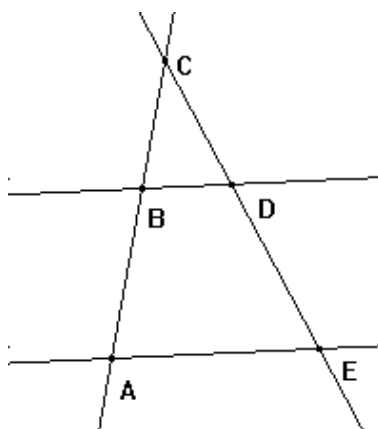

Figure 2

Georgia Department of Education
 Georgia Standards of Excellence Framework
 GSE Geometry • Unit 2

	Side 1	Side 2	Side 3	Perimeter
$\triangle CBD$	$CB =$	$CD =$	$BD =$	$Perim_{\triangle CBD} =$
$\triangle CAE$	$CA =$	$CE =$	$AE =$	$Perim_{\triangle CAE} =$
Ratio	$\frac{CB}{CA} =$	$\frac{CD}{CE} =$	$\frac{BD}{AE} =$	$\frac{Perim_{\triangle CBD}}{Perim_{\triangle CAE}} =$

Answer the following questions:

1. Explain why \overline{AB} (illustrated in figure 2) is a transversal.
2. Explain why segments \overline{CB} and \overline{CA} are called corresponding segments.
3. In view of the last row of results in the table, what appears to be true about the ratio of lengths defined by two transversals intersecting parallel lines?
4. Grab different points and lines in the construction and move them around, if possible. While all of the measurements will change, one relationship will continue to hold no matter how the construction is changed. What is that relationship?
5. Compare your findings from question 4 to those of a classmate. Did everyone discover the same relationship?
6. Use the relationship that you have observed to solve for the unknown quantities in each of the following figures. You may assume that lines which look parallel in each figure are parallel.

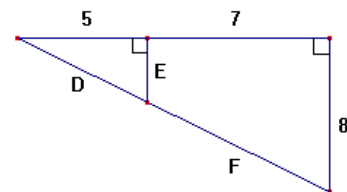
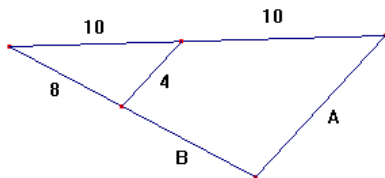
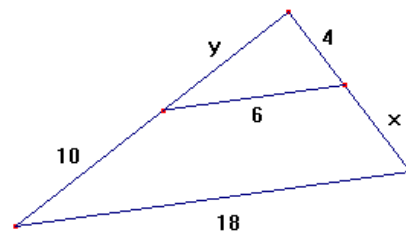
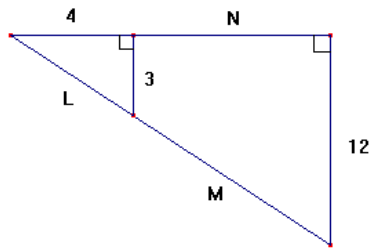

Triangle Proportionality Theorem

If a line parallel to one side of a triangle intersects the other two sides, then it divides the two sides proportionally.

Proof #1:

Given: $\overleftrightarrow{EF} \parallel \overleftrightarrow{BC}$

Prove: $\frac{AE}{EB} = \frac{AF}{FC}$

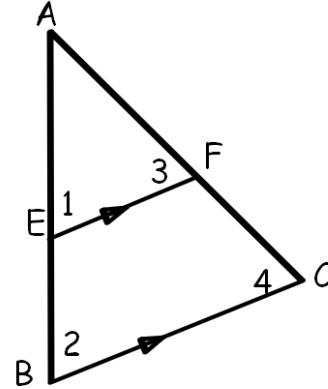

Complete the proof:

Show that $\triangle AEF \sim \triangle ABC$

Since $\overleftrightarrow{EF} \parallel \overleftrightarrow{BC}$, you can conclude that $\angle 1 \cong \angle 2$ and $\angle 3 \cong \angle 4$ by _____

So $\triangle AEF \sim \triangle ABC$ by _____

Use the fact that corresponding sides of similar triangles are proportional to complete the proof

$\frac{AB}{AE} =$ _____ Corresponding sides are proportional

$\frac{AE+EB}{AE} =$ _____ Segment Addition Postulate

$1 + \frac{EB}{AE} =$ _____ Use the property that $\frac{a+b}{c} = \frac{a}{c} + \frac{b}{c}$

$\frac{EB}{AE} =$ _____ Subtract 1 from both sides.

$\frac{AE}{EB} =$ _____ Take the reciprocal of both sides.

Converse of the Triangle Proportionality Theorem

If a line divides two sides of a triangle proportionally, then it is parallel to the third side

Proof #2

Given: $\frac{AE}{EB} = \frac{AF}{FC}$

Prove: $\overleftrightarrow{EF} \parallel \overleftrightarrow{BC}$

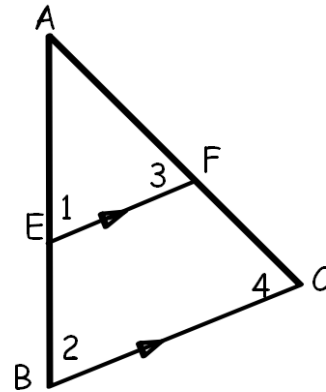

Complete the proof. Show that $\triangle AEF \sim \triangle ABC$

It is given that $\frac{AE}{EB} = \frac{AF}{FC}$ and taking the reciprocal of both sides show that _____.

Now add 1 to both sides by adding $\frac{AE}{AE}$ to the left side and $\frac{AF}{AF}$ to the right side.

Adding and using the Segment Addition Postulate gives _____.

Since $\angle A \cong \angle A$, $\triangle AEF \sim \triangle ABC$ by _____

As corresponding angles of similar triangles, $\angle AEF \cong$ _____

So, $\overleftrightarrow{EF} \parallel \overleftrightarrow{BC}$ by _____

Let's practice finding the length of a segment since you know how to prove the Triangle Proportionality Theorem and its converse.

1. What is the length of NR?

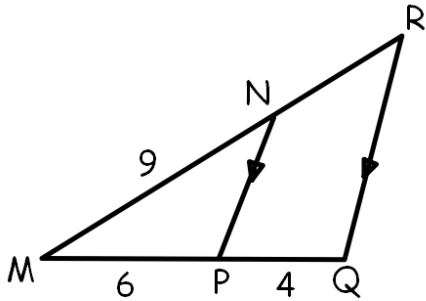

2. What is the length of DF?

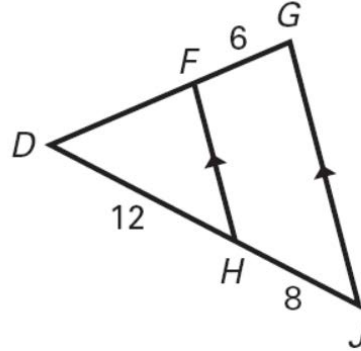

3. Given the diagram, determine whether \overline{MN} is parallel to \overline{PQ} .

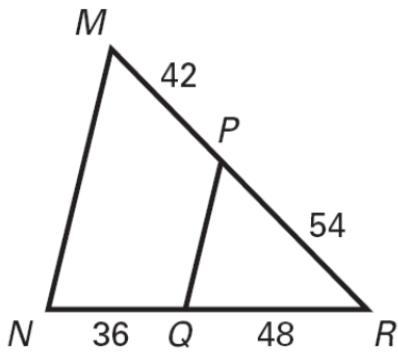

Challenges from Ancient Greece

Mathematical Goals

- Make formal geometric constructions with a variety of tools and methods.
- Use congruent triangles to justify geometric constructions.

STANDARDS ADDRESSED IN THIS TASK

MGSE9-12.G.CO.12 Make formal geometric constructions with a variety of tools and methods (compass and straightedge, string, reflective devices, paper folding, dynamic geometric software, etc.). Copying a segment; copying an angle; bisecting a segment; bisecting an angle; constructing perpendicular lines, including the perpendicular bisector of a line segment; and constructing a line parallel to a given line through a point not on the line.

Standards for Mathematical Practice

- 4. Model with mathematics** by expecting students to apply the mathematics concepts they know in order to solve problems arising in everyday situations, and reflect on whether the results are sensible for the given scenario.
- 5. Use appropriate tools strategically** by expecting students to consider available tools when solving a mathematical problem. These tools might include pencil and paper, concrete models, a ruler, a protractor, a compass, a calculator, software, etc.
- 6. Attend to precision** by requiring students to calculate efficiently and accurately; and to communicate precisely with others by using clear mathematical language to discuss their reasoning.
- 7. Look for and make use of structure** by expecting students to apply rules, look for patterns and analyze structure.
- 8. Look for and express regularity in repeated reasoning** by expecting students to understand broader applications and look for structure and general methods in similar situations.

Student Misconception

Some students may believe that a construction is the same as a sketch or drawing. Emphasize the need for precision and accuracy when doing constructions. Stress the idea that a compass and straightedge are identical to a protractor and ruler. Explain the difference between measurement and construction.

Introduction

In this task, students will investigate and perform geometric constructions using Euclidean tools. The focus of this task is to learn how to copy line segments, copy an angle, bisect a segment, and bisect an angle.

It is highly recommended that students have access to tools such as a Mira™ or reflective mirror and Patty Paper™ to assist developing conceptual understandings of the geometry. During

construction activities, students should also use technology, such as Geometer’s Sketchpad to reinforce straight edge and compass work and to assist with dexterity challenges.

Materials

- compass and straightedge
 - Mira™ or reflective mirror
 - graph paper
 - patty paper or tracing paper (optional)
-

The study of Geometry was born in Ancient Greece, where mathematics was thought to be embedded in everything from music to art to the governing of the universe. Plato, an ancient philosopher and teacher, had the statement, “Let no man ignorant of geometry enter here,” placed at the entrance of his school. This illustrates the importance of the study of shapes and logic during that era. Everyone who learned geometry was challenged to construct geometric objects using two simple tools, known as Euclidean tools:

- A straight edge without any markings
- A compass

The straight edge could be used to construct lines, the compass to construct circles. As geometry grew in popularity, math students and mathematicians would challenge each other to create constructions using only these two tools. Some constructions were fairly easy (Can you construct a square?), some more challenging, (Can you construct a regular pentagon?), and some impossible even for the greatest geometers (Can you trisect an angle? In other words, can you divide an angle into three equal angles?). Archimedes (287-212 B.C.E.) came close to solving the trisection problem, but his solution used a marked straight edge. What constructions can you create?

Your First Challenge: Can you copy a line segment?

- | | |
|--------|---|
| Step 1 | <i>Have students construct a circle with a compass on a sheet of paper.</i> |
| Step 2 | <i>Have students mark the center of the circle and label it point A.</i> |
| Step 3 | <i>Have students mark a point on the circle and label it point B.</i> |
| Step 4 | <i>Have students draw \overline{AB}.</i> |

Questions to ask students:

- What do you know about a circle?
 - Students should explain the different parts of a circle.
- How can we copy segment AB?

- If students struggle to answer this question, complete the next set and ask the question again.

- Step 1 *Have students place the point of the compass on the center of the circle (point A) and the pencil on point B. This is how you measure the length of a segment using a compass.*
- Step 2 *Have students draw a second circle without changing the width of the compass.*
- Step 3 *Have students mark the center of the circle and label it point C.*
- Step 4 *Have students mark a point on the circle and label it point D.*
- Step 5 *Have students draw \overline{CD} .*
- Step 6 *Have students measure the length of segment AB and segment CD using only the compass.*
- Step 7 *Have students compare the length of segment AB and segment CD.*
- Step 8 *Have students trace segment AB on tracing paper.*
- Step 9 *Have students place tracing paper on segment CD.*
- Step 10 *Ask students if there is a relationship between the segments?
Students should recognize that the lengths of the segments are the same because the radii had the same lengths.*

Teacher Notes

Students may need to repeat creating multiple circles before completing the second challenge. Also, students may use arcs instead of circles after demonstrating conceptual understanding.

Your Second Challenge: Can you copy any line segment?

Below is a line segment \overline{AB} . Using only an unmarked straight edge and compass, can you construct another line segment the same length beginning at point C? Write instructions that explain the steps you used to complete the construction. (*Hint: An ancient geometer would require you to “cut off from the greater of two lines” a line segment equal to a given segment.*)

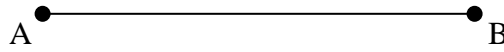

Writing instructions for the constructions is a critical component of the task since it is a precursor to writing proofs. Just as students learn to write papers by creating and revising drafts, students need ample time to write, critique, and revise their instructions. By using peers to proofread instructions, students learn both how to write clear instructions and how to critique and provide feedback on how to refine the instructions. Teachers should allot sufficient instructional time for this writing process.

Possible Solution

A line segment is constructed through point C that is visually longer than \overline{AB} . A circle with center C and radius AB is constructed. (Typically students will first construct a circle with center A and radius AB and use that measure to construct the second circle). Label one of the intersections of the circle with center C and the first line segment constructed as point D.

$$\overline{AB} \cong \overline{CD}$$

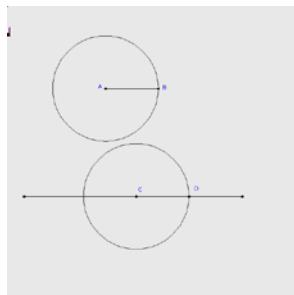

or

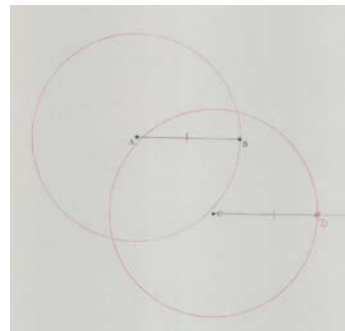

Your Third Challenge: Can you copy an angle?

Now that you know how to copy a segment, copying an angle is easy. How would you construct a copy of an angle at a new point? Discuss this with a partner and come up with a strategy. Think about what congruent triangles are imbedded in your construction and use them to justify why your construction works. Be prepared to share your ideas with the class.

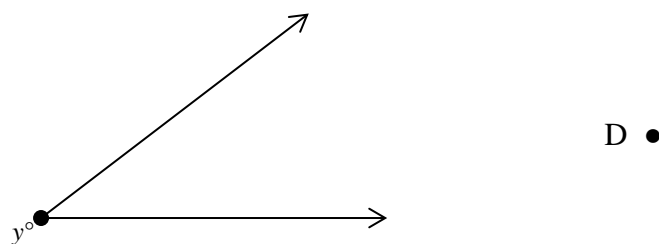

Possible Solution

A possible solution is demonstrated below. Note that there are other correct methods that students may decide to use. DO NOT limit their creativity for this unless their mathematical reasoning is incorrect.

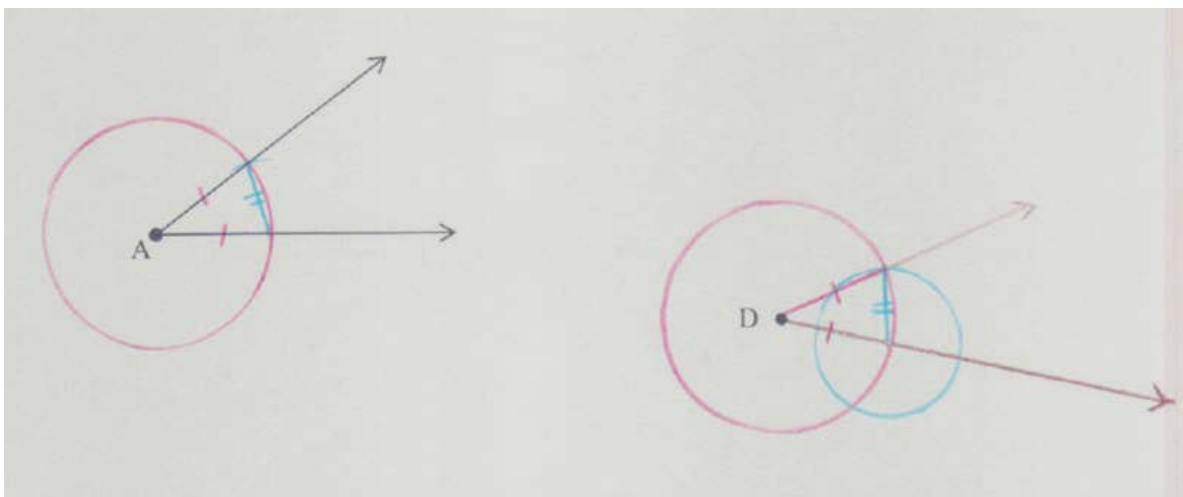

*Create a circle or arc with center A that intersects the visible sides of the angle.
Draw a line segment by connecting the points of intersection formed by creating the circle.
Copy this line segment as learned earlier in this unit.
The justification of this construction is almost obvious when the radii are marked and show the congruent triangles.
If students need further justification, they may cut out the triangles and test that they are identical.*

As an extension, teachers may wish to assign a mathematics history project exploring the contributions of ancient Greek mathematics and mathematicians.

Your Fourth Challenge: Can you bisect a segment?

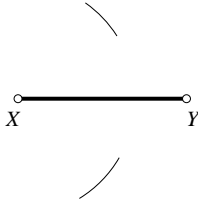
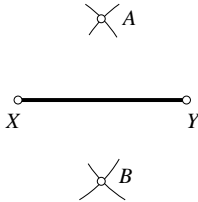
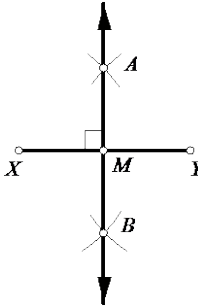
<p>1. Begin with line segment XY.</p>	
<p>2. Place the compass at point X. Adjust the compass radius so that it is more than $(\frac{1}{2})XY$. Draw two arcs as shown here.</p>	
<p>3. Without changing the compass radius, place the compass on point Y. Draw two arcs intersecting the previously drawn arcs. Label the intersection points A and B.</p>	
<p>4. Using the straightedge, draw line AB. Label the intersection point M. Point M is the midpoint of line segment XY, and line AB is perpendicular to line segment XY.</p>	

Construct the perpendicular bisector of the segments. Mark congruent segments and right angles. Check your work with a protractor.

1.

2.

3.

Your Fifth Challenge: Can you bisect an angle?

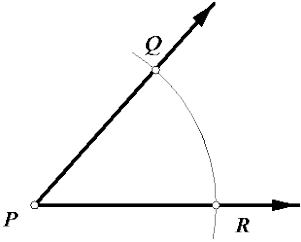
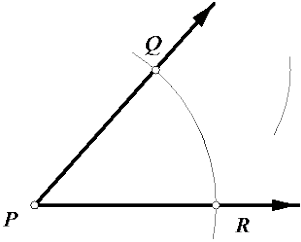
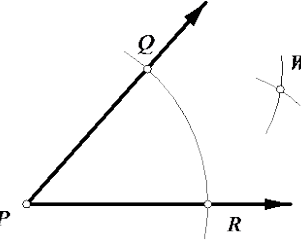
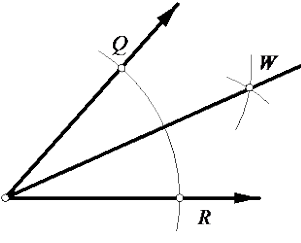
<p>1. Let point P be the vertex of the angle. Place the compass on point P and draw an arc across both sides of the angle. Label the intersection points Q and R.</p>	
<p>2. Place the compass on point Q and draw an arc across the interior of the angle.</p>	
<p>3. Without changing the radius of the compass, place it on point R and draw an arc intersecting the one drawn in the previous step. Label the intersection point W.</p>	
<p>4. Using the straightedge, draw ray PW. This is the bisector of $\angle QPR$.</p>	

Georgia Department of Education
Georgia Standards of Excellence Framework
GSE Geometry • Unit 2

Construct the angle bisector. Mark congruent angles. Check your construction by measuring with a protractor.

1.

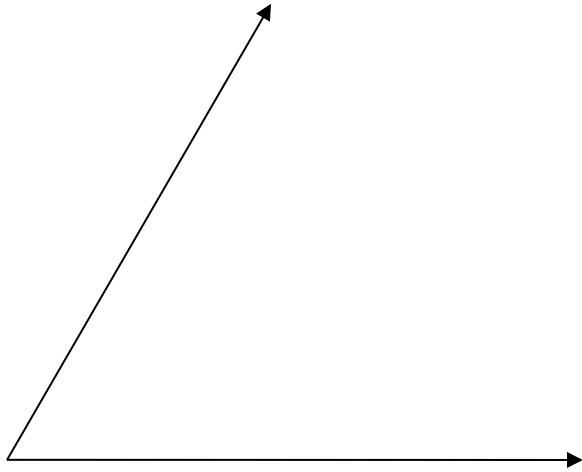

2.

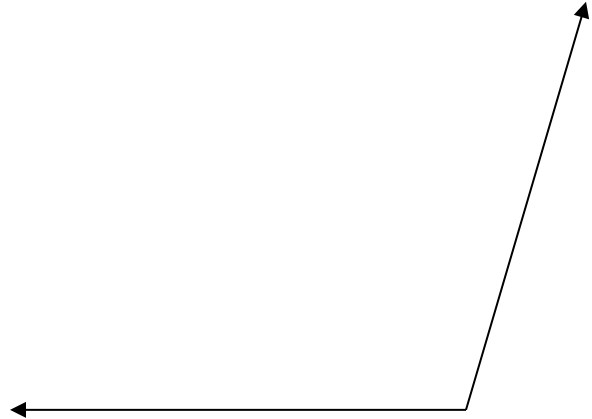

Challenges from Ancient Greece

Mathematical Goals

- Make formal geometric constructions with a variety of tools and methods.
- Use congruent triangles to justify geometric constructions.

STANDARDS ADDRESSED IN THIS TASK

MGSE9-12.G.CO.12 Make formal geometric constructions with a variety of tools and methods (compass and straightedge, string, reflective devices, paper folding, dynamic geometric software, etc.). Copying a segment; copying an angle; bisecting a segment; bisecting an angle; constructing perpendicular lines, including the perpendicular bisector of a line segment; and constructing a line parallel to a given line through a point not on the line.

Standards for Mathematical Practice

4. Model with mathematics by expecting students to apply the mathematics concepts they know in order to solve problems arising in everyday situations, and reflect on whether the results are sensible for the given scenario.

5. Use appropriate tools strategically by expecting students to consider available tools when solving a mathematical problem. These tools might include pencil and paper, concrete models, a ruler, a protractor, a compass, a calculator, software, etc.

6. Attend to precision by requiring students to calculate efficiently and accurately; and to communicate precisely with others by using clear mathematical language to discuss their reasoning.

7. Look for and make use of structure by expecting students to apply rules, look for patterns and analyze structure.

8. Look for and express regularity in repeated reasoning by expecting students to understand broader applications and look for structure and general methods in similar situations.

Introduction

In this task, students will investigate and perform geometric constructions using Euclidean tools. The focus of this task is to learn how to copy line segments, copy an angle, bisect a segment, and bisect an angle.

It is highly recommended that students have access to tools such as a Mira™ or reflective mirror and Patty Paper™ to assist developing conceptual understandings of the geometry. During construction activities, students should also use technology, such as Geometer's Sketchpad to reinforce straight edge and compass work and to assist with dexterity challenges.

Materials

- compass and straightedge
- Mira™ or reflective mirror

- graph paper
 - patty paper or tracing paper (optional)
-

The study of Geometry was born in Ancient Greece, where mathematics was thought to be embedded in everything from music to art to the governing of the universe. Plato, an ancient philosopher and teacher, had the statement, “Let no man ignorant of geometry enter here,” placed at the entrance of his school. This illustrates the importance of the study of shapes and logic during that era. Everyone who learned geometry was challenged to construct geometric objects using two simple tools, known as Euclidean tools:

- A straight edge without any markings
- A compass

The straight edge could be used to construct lines, the compass to construct circles. As geometry grew in popularity, math students and mathematicians would challenge each other to create constructions using only these two tools. Some constructions were fairly easy (Can you construct a square?), some more challenging, (Can you construct a regular pentagon?), and some impossible even for the greatest geometers (Can you trisect an angle? In other words, can you divide an angle into three equal angles?). Archimedes (287-212 B.C.E.) came close to solving the trisection problem, but his solution used a marked straight edge. What constructions can you create?

Your First Challenge: Can you copy a line segment?

- | | |
|--------|--|
| Step 1 | Construct a circle with a compass on a sheet of paper. |
| Step 2 | Mark the center of the circle and label it point A. |
| Step 3 | Mark a point on the circle and label it point B. |
| Step 4 | Draw \overline{AB} . |

Your Second Challenge: Can you copy any line segment?

Below is a line segment \overline{AB} . Using only an unmarked straight edge and compass, can you construct another line segment the same length beginning at point C? Write instructions that explain the steps you used to complete the construction. (*Hint: An ancient geometer would require you to “cut off from the greater of two lines” a line segment equal to a given segment.*)

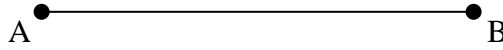

• C

Your Third Challenge: Can you copy an angle?

Now that you know how to copy a segment, copying an angle is easy. How would you construct a copy of an angle at a new point? Discuss this with a partner and come up with a strategy. Think about what congruent triangles are imbedded in your construction and use them to justify why your construction works. Be prepared to share your ideas with the class.

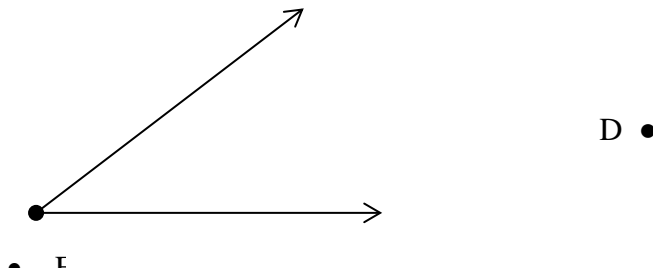

Your Fourth Challenge: Can you bisect a segment?

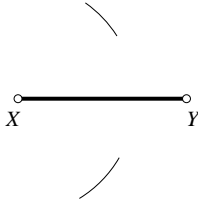
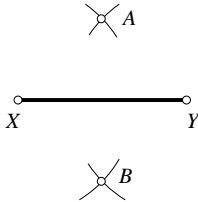
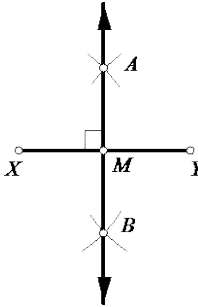
<p>1. Begin with line segment XY.</p>	
<p>2. Place the compass at point X. Adjust the compass radius so that it is more than $(\frac{1}{2})XY$. Draw two arcs as shown here.</p>	
<p>3. Without changing the compass radius, place the compass on point Y. Draw two arcs intersecting the previously drawn arcs. Label the intersection points A and B.</p>	
<p>4. Using the straightedge, draw line AB. Label the intersection point M. Point M is the midpoint of line segment XY, and line AB is perpendicular to line segment XY.</p>	

Construct the perpendicular bisector of the segments. Mark congruent segments and right angles. Check your work with a protractor.

1.

Georgia Department of Education
Georgia Standards of Excellence Framework
GSE Geometry • Unit 2

2.

3.

Your Fifth Challenge: Can you bisect an angle?

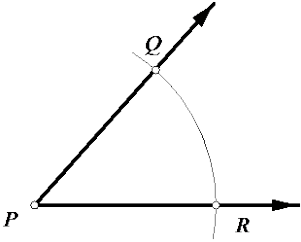
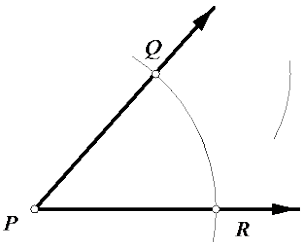
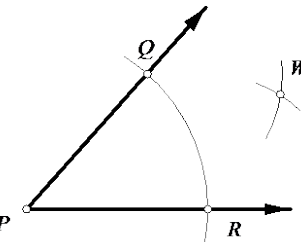
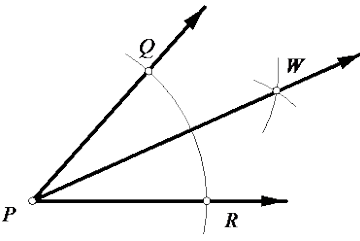
<p>1. Let point P be the vertex of the angle. Place the compass on point P and draw an arc across both sides of the angle. Label the intersection points Q and R.</p>	
<p>2. Place the compass on point Q and draw an arc across the interior of the angle.</p>	
<p>3. Without changing the radius of the compass, place it on point R and draw an arc intersecting the one drawn in the previous step. Label the intersection point W.</p>	
<p>4. Using the straightedge, draw ray PW. This is the bisector of $\angle QPR$.</p>	

Georgia Department of Education
Georgia Standards of Excellence Framework
GSE Geometry • Unit 2

Construct the angle bisector. Mark congruent angles. Check your construction by measuring with a protractor.

1.

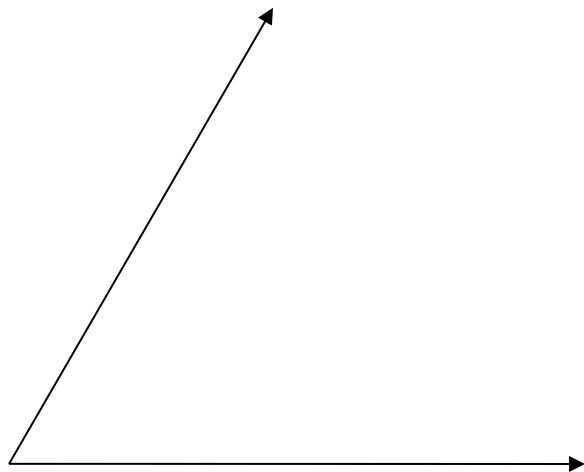

2.

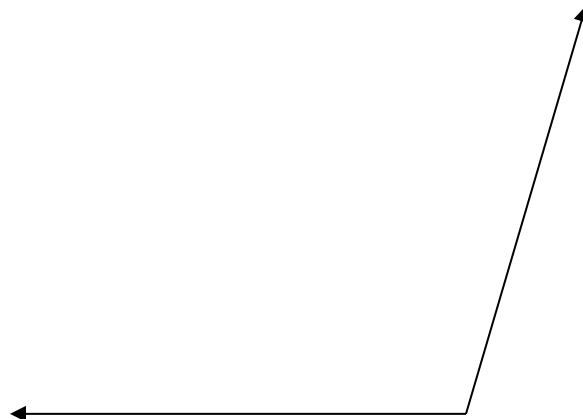

Constructing Parallel and Perpendicular Lines

Mathematical Goals

- Make formal geometric constructions with a variety of tools and methods.
- Use congruent triangles to justify geometric constructions.

STANDARDS ADDRESSED IN THIS TASK

MGSE9-12.G.CO.12 Make formal geometric constructions with a variety of tools and methods (compass and straightedge, string, reflective devices, paper folding, dynamic geometric software, etc.). Copying a segment; copying an angle; bisecting a segment; bisecting an angle; constructing perpendicular lines, including the perpendicular bisector of a line segment; and constructing a line parallel to a given line through a point not on the line.

Standards for Mathematical Practice

- 4. Model with mathematics** by expecting students to apply the mathematics concepts they know in order to solve problems arising in everyday situations, and reflect on whether the results are sensible for the given scenario.
- 5. Use appropriate tools strategically** by expecting students to consider available tools when solving a mathematical problem. These tools might include pencil and paper, concrete models, a ruler, a protractor, a compass, a calculator, software, etc.
- 6. Attend to precision** by requiring students to calculate efficiently and accurately; and to communicate precisely with others by using clear mathematical language to discuss their reasoning.
- 7. Look for and make use of structure** by expecting students to apply rules, look for patterns and analyze structure.
- 8. Look for and express regularity in repeated reasoning** by expecting students to understand broader applications and look for structure and general methods in similar situations.

Student Misconception

Some students may believe that a construction is the same as a sketch or drawing. Emphasize the need for precision and accuracy when doing constructions. Stress the idea that a compass and straightedge are identical to a protractor and ruler. Explain the difference between measurement and construction.

Introduction

In this task, students will use geometric constructions to construct perpendicular and parallel lines. Some teachers may choose to have students discover this construction, if time allows, however the focus of the activity is to observe properties of parallel lines. These properties include that parallel lines are everywhere equidistant and that two lines perpendicular to the same line are parallel. It is important to prompt students to provide informal explanations as to why the lines they construct are parallel that move beyond statements such as “they just look parallel.”

It is highly recommended that teachers use tools such as a Mira™ or reflective mirror and patty paper or tracing paper to assist developing conceptual understandings of the geometry.

Materials

- compass and straight edge
- Mira™ or reflective mirror
- graph paper
- patty paper or tracing paper (optional)

Let's start by exploring features of parallel lines.

In the figure below, lines m and n are parallel and the line t intersects both.

- Label a new point C anywhere you choose on the line m . Connect B and C to form $\triangle ABC$.
- Construct a point D on line n so that points D and C are on opposite sides of line t and $AC = BD$.
- Verify that $\triangle ABC$ is congruent to $\triangle ABD$.

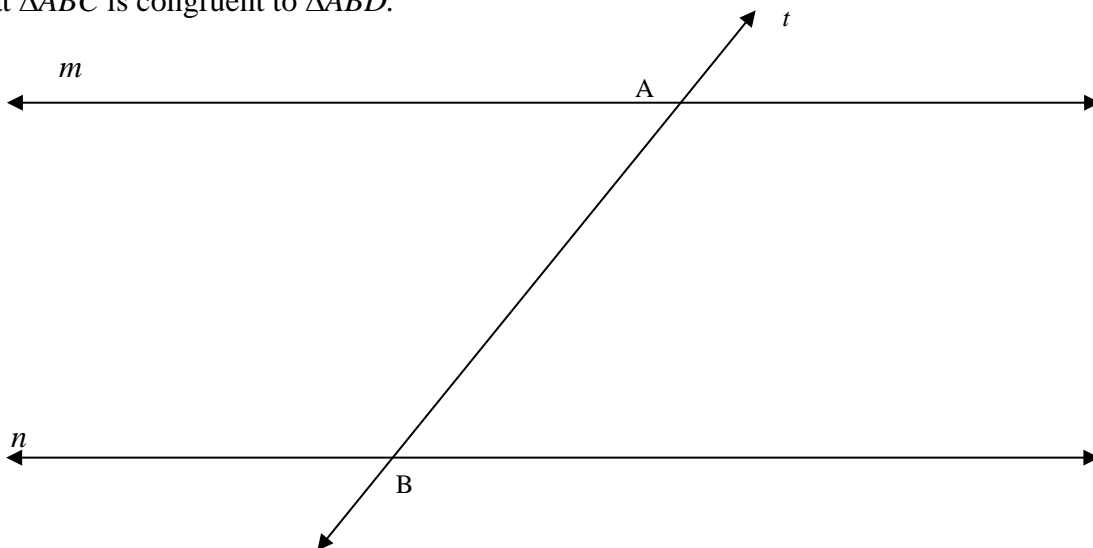

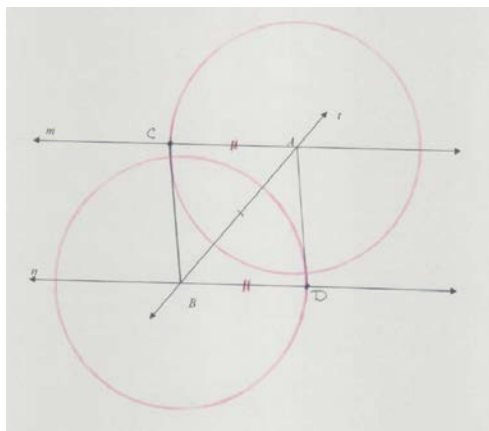

One way to verify that the two triangles are congruent is to cut them out and hold them together. This is an easy way for them to notice the corresponding parts are congruent. The teacher may suggest that they label the parts in a way that the labels are visible after they are cut out.

1. Name all corresponding and congruent parts of this construction.

Students may find it difficult to recognize congruent triangles that share a side or are not a reflection at this point, so they are led first to examine the three sets of corresponding congruent sides.

$AC \cong BE$; $AB \cong AB$; $BC \cong ED$ and $\angle CAB \cong \angle EBD$; $\angle ACB \cong \angle BED$; $\angle ABC \cong \angle BDE$

2. What can you conclude about $\angle CAB$ and $\angle DBA$? Will this always be true, regardless of where you choose C to be? Does it matter how line t is drawn? (In other words could line t be perpendicular to both lines? Or slanted the other way?)

The angles will always be congruent because of the congruent triangles which were constructed. Students may wish to create additional constructions to verify this, but this is a key observation of the construction. It does not matter how line t is drawn.

3. What type of quadrilateral is CADB? Why do you think this is true?

The quadrilateral is a parallelogram.

Teachers may use guiding questions to reinforce properties of parallelograms:

What makes a quadrilateral a parallelogram? (Opposite sides are both congruent and parallel.)

When you divide a parallelogram in half along its diagonal, what is created? (Two congruent triangles are created.)

What parts are congruent in a parallelogram? (Both opposite sides are congruent and opposite angles are congruent.)

Drawing a line that intersects two parallel lines creates two sets of four congruent angles. Use this observation to construct a parallel line to \overline{AB} through a given point P .

P

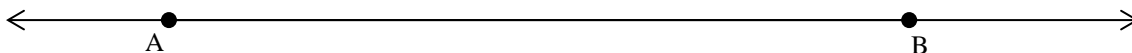

4. Construct a perpendicular line to \overline{AB} that passes through P . Label the intersection with line m as Q .

Construct a perpendicular line to \overline{AB} that passes through P . Label the intersection with line m as Q .

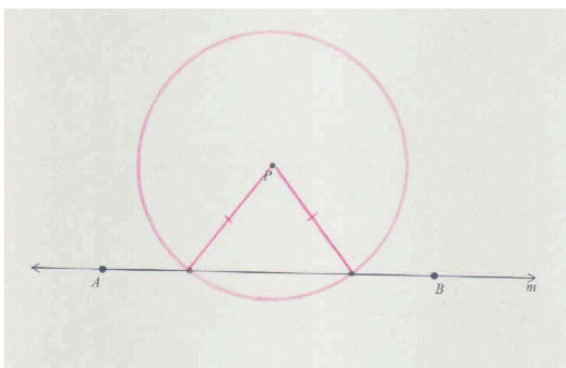

Drawing a circle with center P that intersects line m twice gives us a line segment.

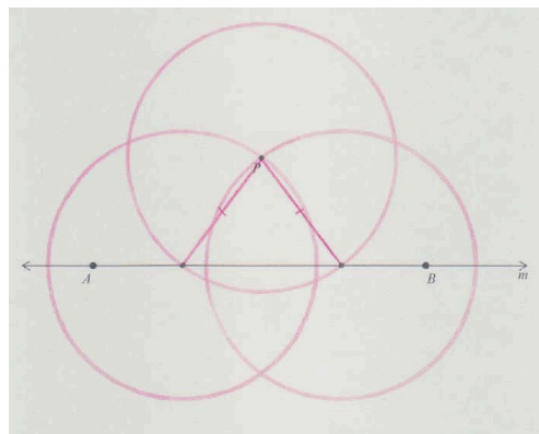

Construct the perpendicular bisector of this line segment by drawing two congruent circles with radii that are more than half the length of this segment using the intersections shown in the previous step as the centers.

Constructing Parallel and Perpendicular Lines

Mathematical Goals

- Make formal geometric constructions with a variety of tools and methods.
- Use congruent triangles to justify geometric constructions.

STANDARDS ADDRESSED IN THIS TASK

MGSE9-12.G.CO.12 Make formal geometric constructions with a variety of tools and methods (compass and straightedge, string, reflective devices, paper folding, dynamic geometric software, etc.). Copying a segment; copying an angle; bisecting a segment; bisecting an angle; constructing perpendicular lines, including the perpendicular bisector of a line segment; and constructing a line parallel to a given line through a point not on the line.

Standards for Mathematical Practice

4. Model with mathematics by expecting students to apply the mathematics concepts they know in order to solve problems arising in everyday situations, and reflect on whether the results are sensible for the given scenario.

5. Use appropriate tools strategically by expecting students to consider available tools when solving a mathematical problem. These tools might include pencil and paper, concrete models, a ruler, a protractor, a compass, a calculator, software, etc.

6. Attend to precision by requiring students to calculate efficiently and accurately; and to communicate precisely with others by using clear mathematical language to discuss their reasoning.

7. Look for and make use of structure by expecting students to apply rules, look for patterns and analyze structure.

8. Look for and express regularity in repeated reasoning by expecting students to understand broader applications and look for structure and general methods in similar situations.

Let's start by exploring features of parallel lines.

In the figure below, lines m and n are parallel and the line t intersects both.

- Label a new point C anywhere you choose on the line m . Connect B and C to form $\triangle ABC$.
- Construct a point D on line n so that points D and C are on opposite sides of line t and $AC = BD$.

- Verify that $\triangle ABC$ is congruent to $\triangle ABD$.

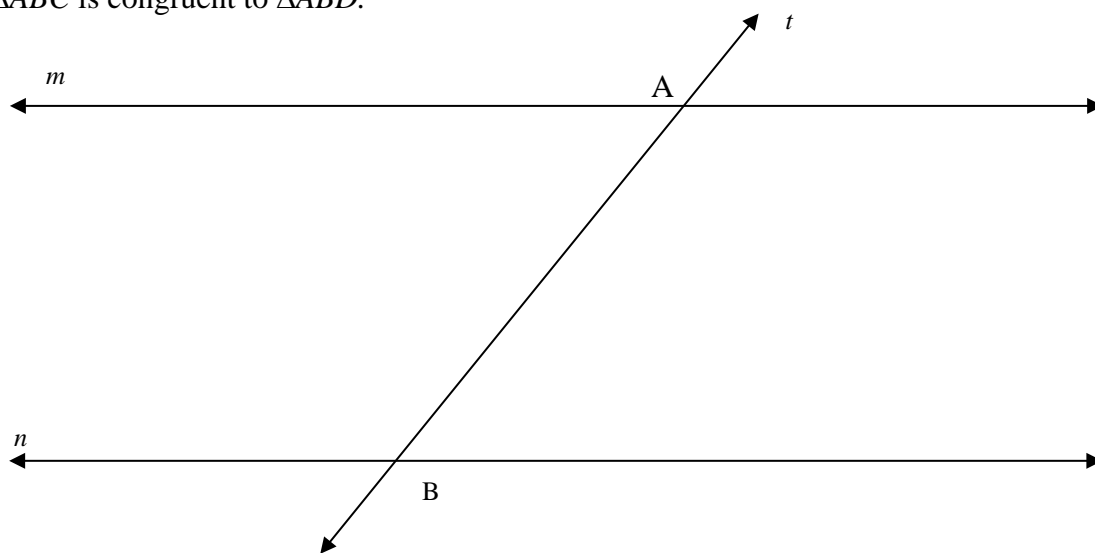

1. Name all corresponding and congruent parts of this construction.
2. What can you conclude about $\angle CAB$ and $\angle DBA$? Will this always be true, regardless of where you choose C to be? Does it matter how line t is drawn? (*In other words could line t be perpendicular to both lines? Or slanted the other way?*)
3. What type of quadrilateral is $CADB$? Why do you think this is true?

Drawing a line that intersects two parallel lines creates two sets of four congruent angles. Use this observation to construct a parallel line to \overline{AB} through a given point P .

P

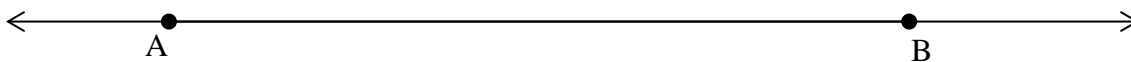

4. Construct a perpendicular line to \overline{AB} that passes through P . Label the intersection with line m as Q .

Constructions Inscribed in a Circle

Adapted from <http://www.mathopenref.com/> 2009 Copyright Math Open Reference.

Mathematical Goals

- Make formal geometric constructions with a variety of tools and methods.
- Use congruent triangles to justify geometric constructions.

STANDARDS ADDRESSED IN THIS TASK

MGSE9-12.G.CO.13 Construct an equilateral triangle, a square, and a regular hexagon, each inscribed in a circle.

Standards for Mathematical Practice

4. Model with mathematics by expecting students to apply the mathematics concepts they know in order to solve problems arising in everyday situations, and reflect on whether the results are sensible for the given scenario.

5. Use appropriate tools strategically by expecting students to consider available tools when solving a mathematical problem. These tools might include pencil and paper, concrete models, a ruler, a protractor, a compass, a calculator, software, etc.

6. Attend to precision by requiring students to calculate efficiently and accurately; and to communicate precisely with others by using clear mathematical language to discuss their reasoning.

7. Look for and make use of structure by expecting students to apply rules, look for patterns and analyze structure.

8. Look for and express regularity in repeated reasoning by expecting students to understand broader applications and look for structure and general methods in similar situations.

Student Misconception

Some students may believe that a construction is the same as a sketch or drawing.

Emphasize the need for precision and accuracy when doing constructions. Stress the idea that a compass and straightedge are identical to a protractor and ruler. Explain the difference between measurement and construction.

Introduction

Allow students to explore possible methods for constructing equilateral triangles, squares, and hexagons, and methods for constructing each inscribed in a circle. In this task, students will use geometric constructions to make a regular hexagon inscribed in a circle. After working through the steps to make this construction, students will determine how to construct an equilateral triangle inscribed in a circle.

Materials

- compass
- straight edge
- patty paper or tracing paper (optional)

We start with the given circle, center O.



1. Mark a point anywhere on the circle. Label this point P. This will be the first vertex of the hexagon.



2. Set the compass on point P and set the width of the compass to the center of the circle O. The compass is now set to the radius of the circle \overline{OP} .

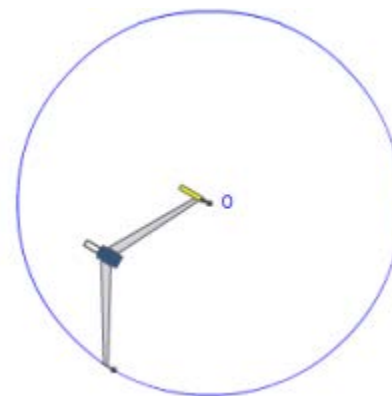

3. Make an arc across the circle. This will be the next vertex of the hexagon. Call this point Q.

(It turns out that the side length of a hexagon is equal to its circumradius - the distance from the center to a vertex).

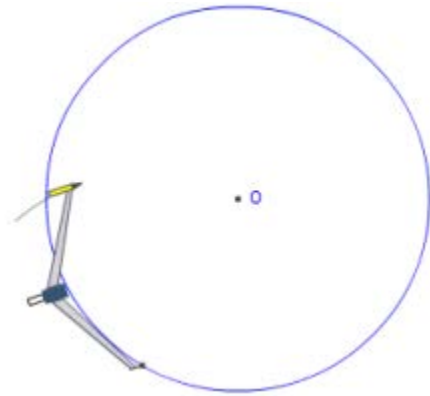

4. Move the compass on to the next vertex Q and draw another arc. This is the third vertex of the hexagon. Call this point R.

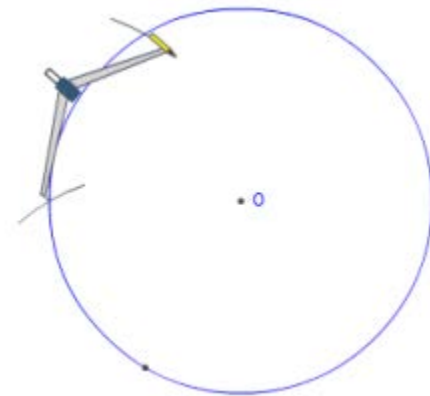

5. Continue in this way until you have all six vertices. PQRSTU

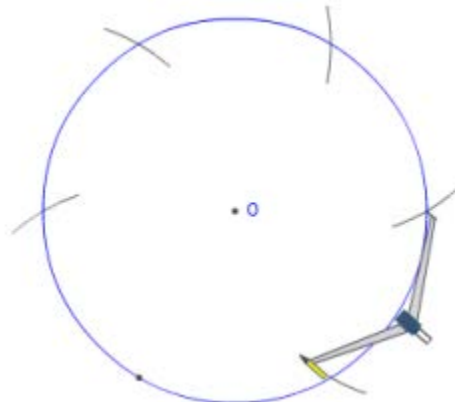

6. Draw a line between each successive pairs of vertices, for a total of six lines.

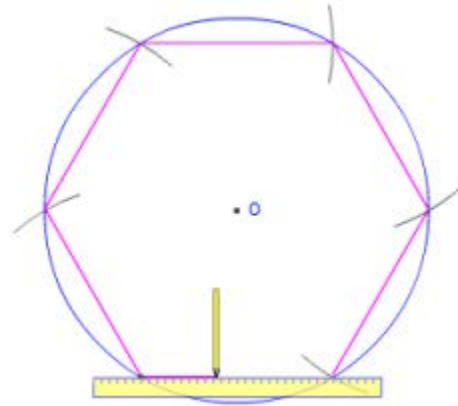

7. Done. These lines form a regular hexagon inscribed in the given circle. Hexagon PQRSTU

Try the example below using the steps to construct a hexagon inscribed in a circle using a compass and straightedge. Then brainstorm with a partner on how to construct an equilateral triangle inscribed in a circle.

1. Construct the largest regular hexagon that will fit in the circle below.

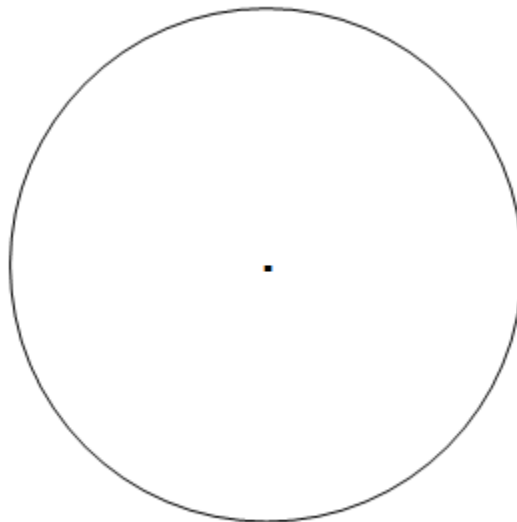

2. How would you construct an equilateral triangle inscribed in a given circle?
3. How would you construct a square inscribed in a given circle?

Georgia Department of Education
Georgia Standards of Excellence Framework
GSE Geometry • Unit 2

Draw a diameter, draw a perpendicular bisector to the diameter, and then connect the four points of intersection with the circle.

Teacher Notes

Connecting the intersections of every other arc yields an equilateral triangle.

Constructions Inscribed in a Circle

Adapted from <http://www.mathopenref.com/> 2009 Copyright Math Open Reference.

Mathematical Goals

- Make formal geometric constructions with a variety of tools and methods.
- Use congruent triangles to justify geometric constructions.

STANDARDS ADDRESSED IN THIS TASK

MGSE9-12.G.CO.13 Construct an equilateral triangle, a square, and a regular hexagon, each inscribed in a circle.

Standards for Mathematical Practice

4. Model with mathematics by expecting students to apply the mathematics concepts they know in order to solve problems arising in everyday situations, and reflect on whether the results are sensible for the given scenario.

5. Use appropriate tools strategically by expecting students to consider available tools when solving a mathematical problem. These tools might include pencil and paper, concrete models, a ruler, a protractor, a compass, a calculator, software, etc.

6. Attend to precision by requiring students to calculate efficiently and accurately; and to communicate precisely with others by using clear mathematical language to discuss their reasoning.

7. Look for and make use of structure by expecting students to apply rules, look for patterns and analyze structure.

8. Look for and express regularity in repeated reasoning by expecting students to understand broader applications and look for structure and general methods in similar situations.

We start with the given circle, center O.



1. Mark a point anywhere on the circle. Label this point P. This will be the first vertex of the hexagon.



2. Set the compass on point P and set the width of the compass to the center of the circle O. The compass is now set to the radius of the circle \overline{OP} .

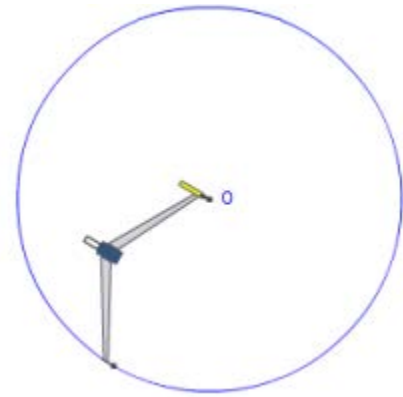

3. Make an arc across the circle. This will be the next vertex of the hexagon. Call this point Q.

(It turns out that the side length of a hexagon is equal to its circumradius - the distance from the center to a vertex).

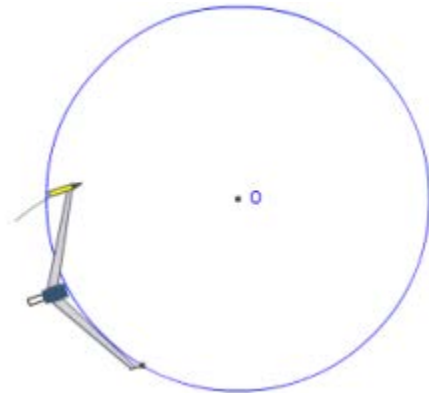

4. Move the compass on to the next vertex Q and draw another arc. This is the third vertex of the hexagon. Call this point R.

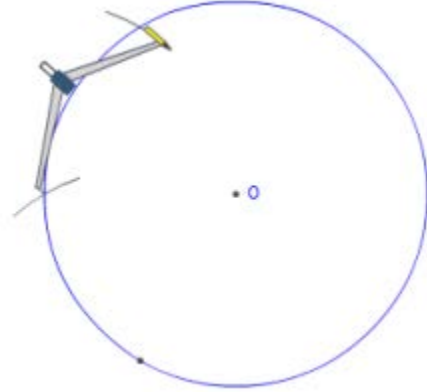

5. Continue in this way until you have all six vertices. PQRSTU

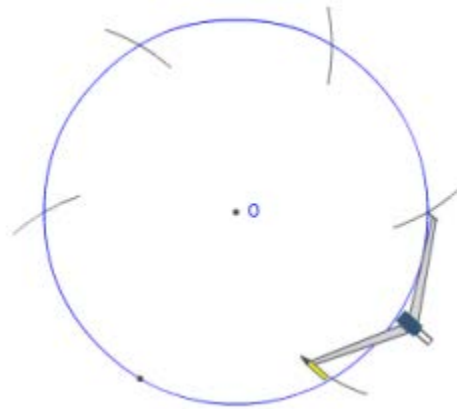

6. Draw a line between each successive pairs of vertices, for a total of six lines.

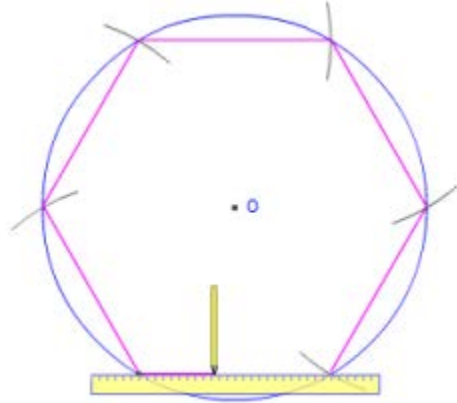

7. Done. These lines form a regular hexagon inscribed in the given circle. Hexagon PQRSTU

Try the example below using the steps to construct a hexagon inscribed in a circle using a compass and straightedge. Then brainstorm with a partner on how to construct an equilateral triangle inscribed in a circle.

1. Construct the largest regular hexagon that will fit in the circle below.

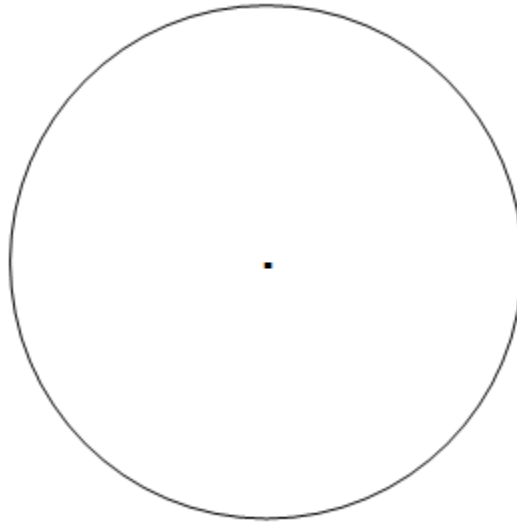

2. How would you construct an equilateral triangle inscribed in a given circle?
3. How would you construct a square inscribed in a given circle?

Centers of Triangles

Mathematical Goals

- Prove the medians of a triangle meet at a point.
- Bisect a segment and an angle.
- Construct perpendicular lines, including the perpendicular bisector of a line segment.

STANDARDS ADDRESSED IN THIS TASK

MGSE9-12.G.CO.10 Prove theorems about triangles. Theorems include: measures of interior angles of a triangle sum to 180 degrees; base angles of isosceles triangles are congruent; the segment joining midpoints of two sides of a triangle is parallel to the third side and half the length; the medians of a triangle meet at a point.

Standards for Mathematical Practice

1. **Make sense of problems and persevere in solving them** by requiring students to interpret and make meaning of a problem and find a logical starting point, and to monitor their progress and change their approach to solving the problem, if necessary.
2. **Reason abstractly and quantitatively** by requiring students to make sense of quantities and their relationships to one another in problem situations.
3. **Construct viable arguments and critique the reasoning of others** by engaging students on discussion of why they agree or disagree with responses, decide whether they make sense, and ask useful questions to clarify or improve the arguments.
4. **Model with mathematics** by expecting students to apply the mathematics concepts they know in order to solve problems arising in everyday situations, and reflect on whether the results are sensible for the given scenario.
5. **Use appropriate tools strategically** by expecting students to consider available tools when solving a mathematical problem. These tools might include pencil and paper, concrete models, a ruler, a protractor, a compass, a calculator, software, etc.
6. **Attend to precision** by requiring students to calculate efficiently and accurately; and to communicate precisely with others by using clear mathematical language to discuss their reasoning.
7. **Look for and make use of structure** by expecting students to apply rules, look for patterns and analyze structure.
8. **Look for and express regularity in repeated reasoning** by expecting students to understand broader applications and look for structure and general methods in similar situations.

Introduction

In this task students will determine the location for an amusement park by finding the centers of a triangle. The centers will be new to the students but not the constructions. Make sure students remember the significance of points on the perpendicular bisector of a segment (equidistant from the endpoints of the segment) and the points on an angle bisector (equidistant from the sides of the angle).

As students work through the tasks and present their solutions to the class make sure they emphasize the name of the center found, how it was found, and its significance.

The significance of the circumcenter and incenter can be determined through measurement. If needed, encourage students to measure the distances from the triangle centers to the sides and vertices of the triangle. Students can use properties of the perpendicular bisectors and angle bisectors to justify their conjectures about the significance of the circumcenter and the incenter. Students may require help in determining the significance of the centroid (center of gravity). Students can determine one of the significant features of the centroid through measurement (the centroid is twice the distance from the vertex to the opposite side). Other than being the point of concurrency of the altitudes the orthocenter has no additional significance in this task.

This task goes beyond the standard. The standard specifically asks for students to determine that the medians of a triangle meet in a point (centroid). Teachers should use their professional discretion on how much of this task is appropriate for their students.

Materials

- Mira™ or reflective mirror
- graph paper
- patty paper or tracing paper
- compass and straightedge
- Geometer’s Sketchpad or similar geometry software, if possible

Triangle Center:	Point of Concurrency of:	Significance of:
Incenter	Angle bisectors	Center of inscribed circle Equidistant from the sides of the triangle
Circumcenter	Perpendicular bisectors	Center of the circumscribing circle Equidistant from the vertices of the
Orthocenter	Altitudes	
Centroid	Medians	Center of balance or gravity The distance from a vertex

		to the centroid is twice the distance from the centroid to the opposite side.
--	--	---

A developer plans to build an amusement park but wants to locate it within easy access of the three largest towns in the area as shown on the map below. The developer has to decide on the best location and is working with the ABC Construction Company to minimize costs wherever possible. No matter where the amusement park is located, roads will have to be built for access directly to the towns or to the existing highways.

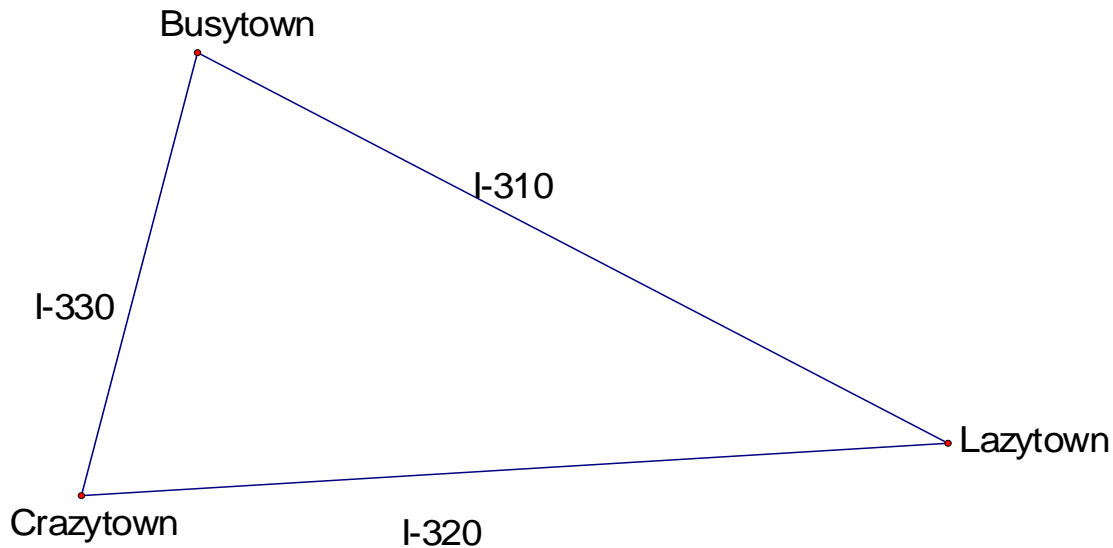

1. Just by looking at the map, choose the location that you think will be best for building the amusement park. Explain your thinking.
2. Now you will use some mathematical concepts to help you choose a location for the tower.

Investigate the problem above by constructing the following:

- i. all 3 medians of the triangle
- ii. all 3 altitudes of the triangle
- iii. all 3 angle bisectors of the triangle
- iv. all 3 perpendicular bisectors of the triangle

You have four different kinds of tools at your disposal- patty paper, MIRA, compass and straight edge, and Geometer's Sketch Pad. Use a different tool for each of your constructions.

Not drawn to scale:

The constructions, regardless of which tool is used, should result in the following. It is very important for students to realize the three lines always intersect in a single point. Because some of the tools they are using are not very precise the students will have some errors in measurement. These errors should be discussed as a group but some conclusions can still be made even with these errors.

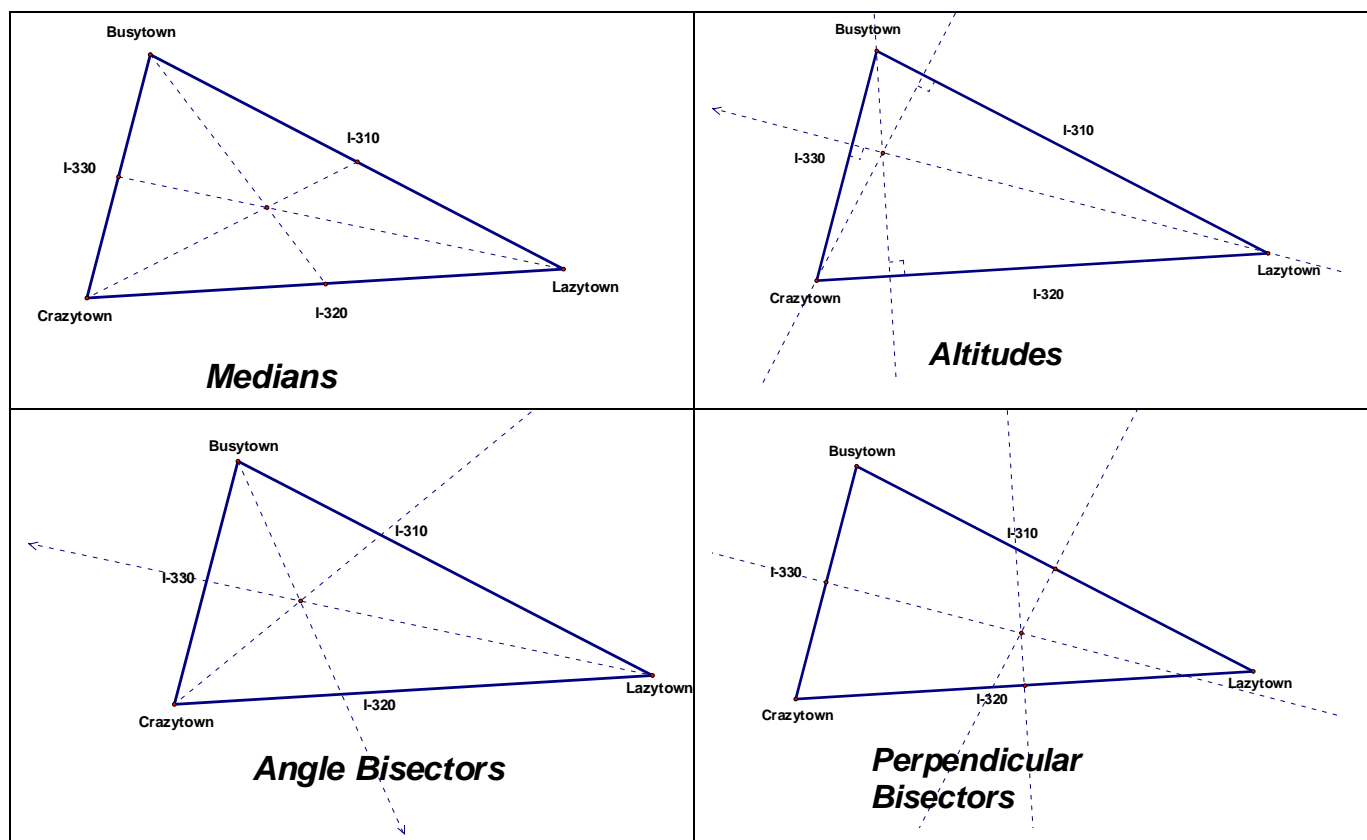

- Choose a location for the amusement park based on the work you did in part 2. Explain why you chose this point.

Solution

Answers will vary, but it is critical for students to have a mathematical justification for their decision. For example, they may choose the circumcenter because it is equidistant from all three cities. Or they may choose the incenter because it is equidistant from each of the roads. They could choose the centroid instead of the circumcenter because it is closer to two of the cities while not being that much further away from Lazytown.

- How close is the point you chose in part 3, based on mathematics, to the point you chose by observation?

Solution

Answers will vary.

You have now discovered that each set of segments resulting from the constructions above always has a point of intersection. These four points of intersection are called the **points of concurrency** of a triangle.

The intersection point of the medians is called the **centroid** of the triangle.

The intersection point of the angle bisectors is called the **incenter** of the triangle.

The intersection point of the perpendicular bisectors is called the **circumcenter** of the triangle.

The intersection point of the altitudes is called the **orthocenter** of the triangle.

Comments

Students struggle with using the terms point of concurrency and concurrent lines correctly. Make sure they understand what they mean and how to use them. To help them understand the significance of a point of concurrency, ask them to draw three lines on their paper, without looking at anyone else's paper. Then, ask whose lines are drawn in such a way that all three intersect at the same point. Have them compare their drawings and determine the different ways three lines can be related to each other.

5. Can you give a reasonable guess as to why the specific names were given to each point of concurrency?

Comments

Students will need to have an idea of the significance of the triangle centers in order to answer this question. If they have not already done so, they need to go back to their constructions and explore the properties of the triangle centers they found in #2. Some groups may have discovered these properties already.

Make sure the name of the center, how it was found, and its significance are emphasized as students present their solutions.

Solution

Answers will vary.

6. Which triangle center did you recommend for the location of the amusement park?

Solution

The students are only being asked to name their point. They need to decide if their chosen point is the centroid, incenter, circumcenter, or orthocenter based on the definitions above.

7. The president of the company building the park is concerned about the cost of building roads from the towns to the park. What recommendation would you give him? Write a memo to the president explaining your recommendation.

Comments

Since the president is concerned about the cost of the roads, students need to take that into account in their memo. In consideration of the cost of building the roads, some groups may want to change their earlier decision. For example, if a group chose to use the circumcenter because it was an equal distance from each of the cities they may want to choose the incenter or median to reduce the cost of building the roads. Or, students could measure the total distance from a point of concurrency to each of the cities and choose the center that gives the shortest total distance.

Solution

Answers may vary. Mathematical justification of the answer is the most important aspect of this activity.

Student Sample Work for Centers of Triangles

#1. I think it should go in one of the towns, because other towns might not want to go to amusement parks...

#2.

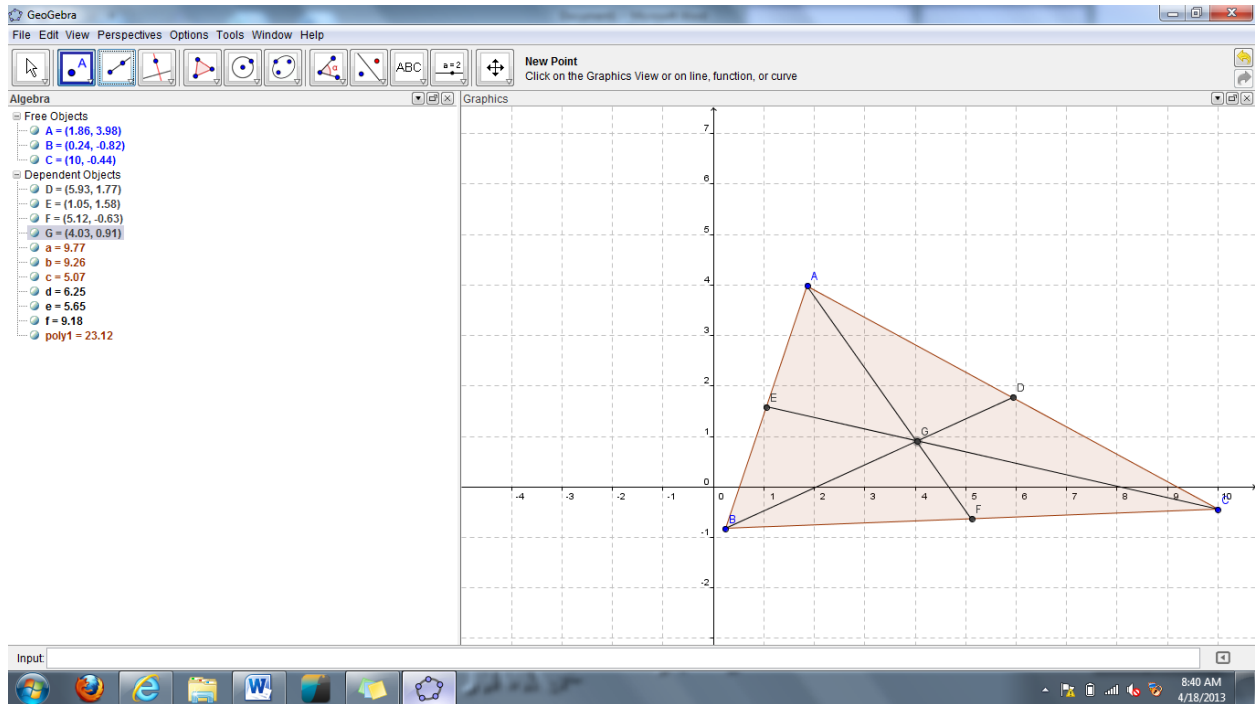

Georgia Department of Education
Georgia Standards of Excellence Framework
GSE Geometry • Unit 2

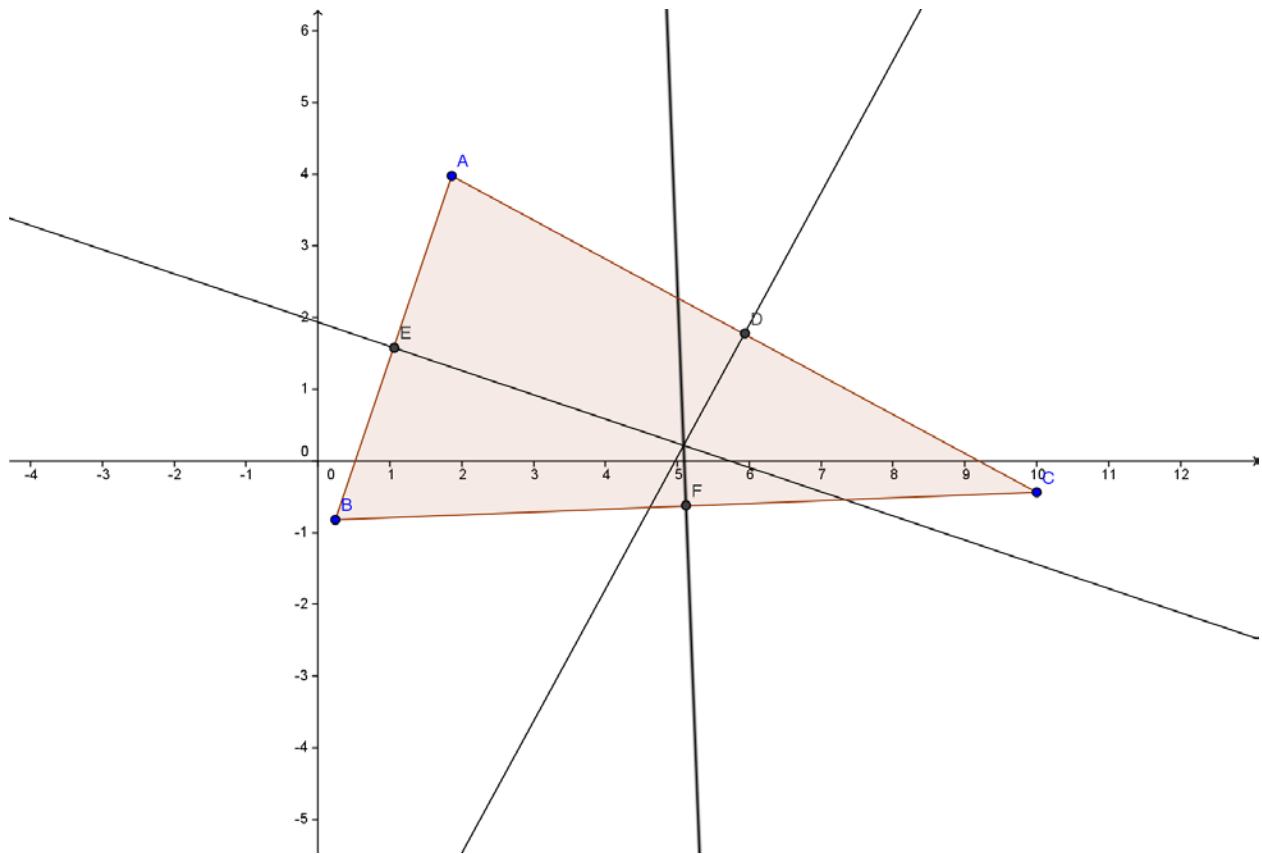

Georgia Department of Education
Georgia Standards of Excellence Framework
GSE Geometry • Unit 2

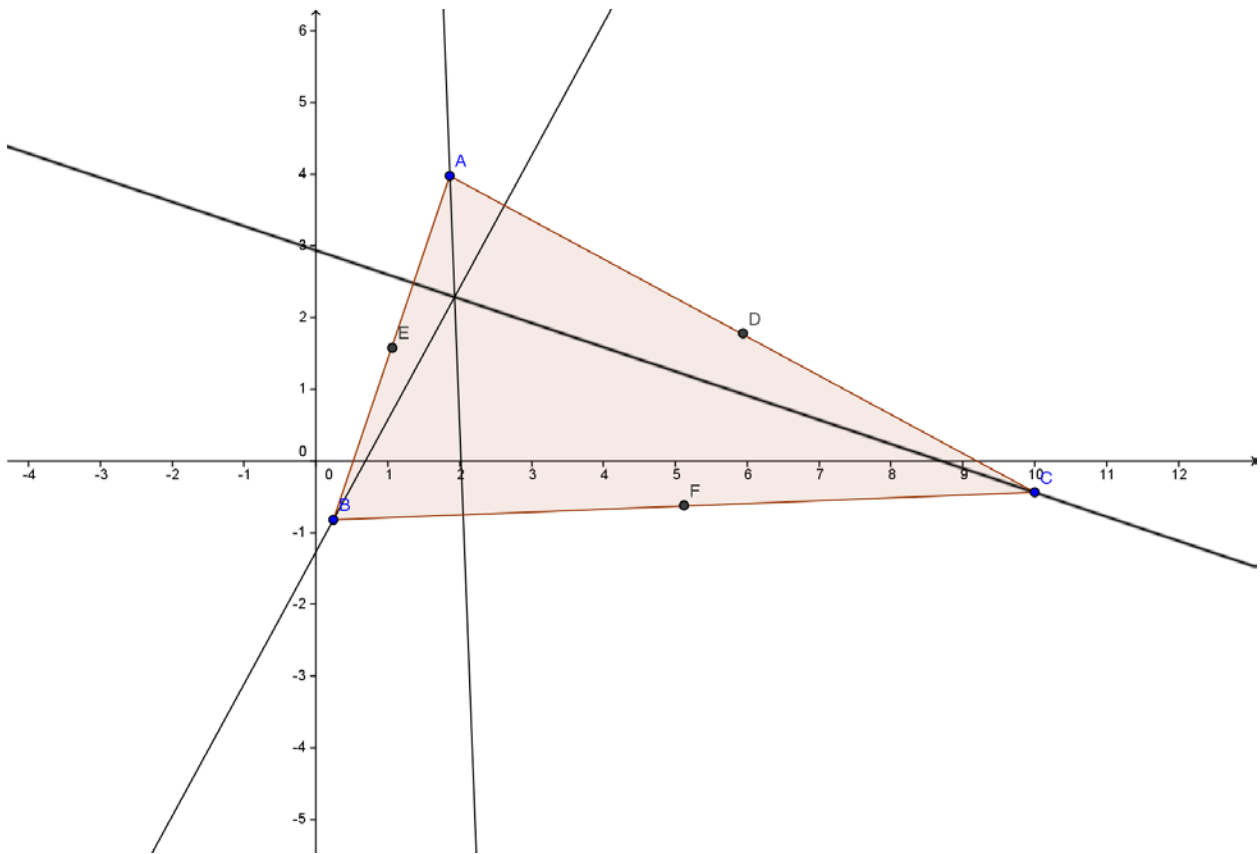

Georgia Department of Education
Georgia Standards of Excellence Framework
GSE Geometry • Unit 2

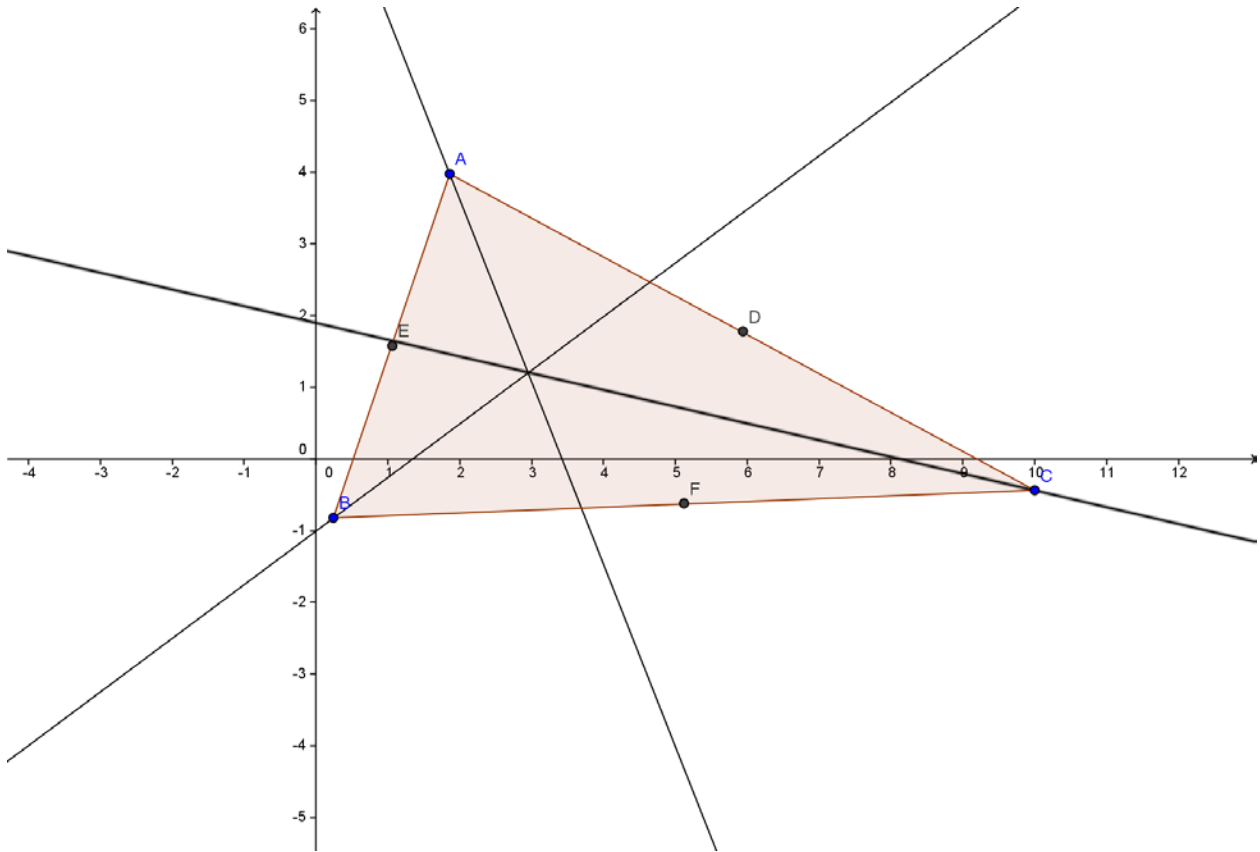

#3. I now think that the Amusement Park will get more visits if it's between all three towns, so it should be the center (centroid) of the triangle. (Marked by point G)

#4. The point I chose on part three is exactly in the middle of the triangle.

#5. I guess that the names were given to each concurrency that way they did not get confused, and because each one is different, but they look similar.

#6. My answer for three, its proper name would be the Centroid of the triangle.

#7.

Dear Mr. President,

There is no need to worry about the roads being built. The cost of building the roads will be cheapest the way I chose. They will have to travel down the interstate and then turn onto a road, which save piles of money. The interstates and the middle of each one make the perfect way to save money.

Georgia Department of Education
Georgia Standards of Excellence Framework
GSE Geometry • Unit 2

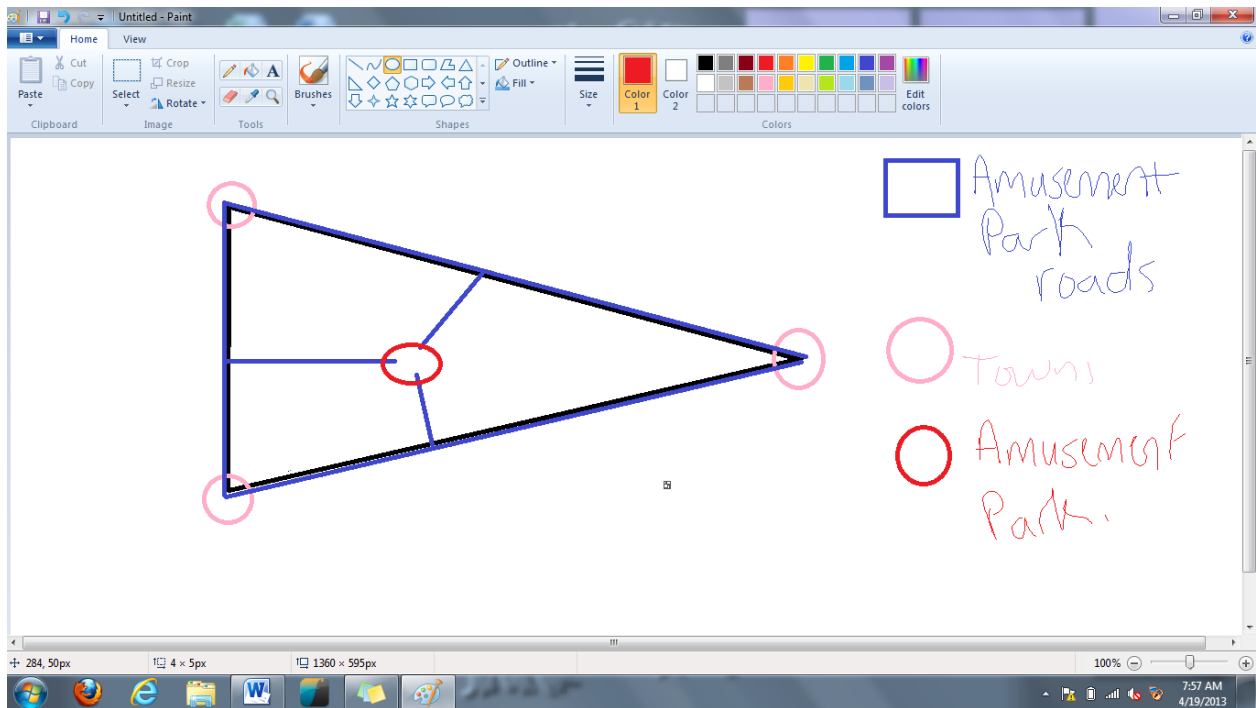

Centers of Triangles

- 1.) I would put the amusement park in the middle of all of the angles. Where the lines cross.

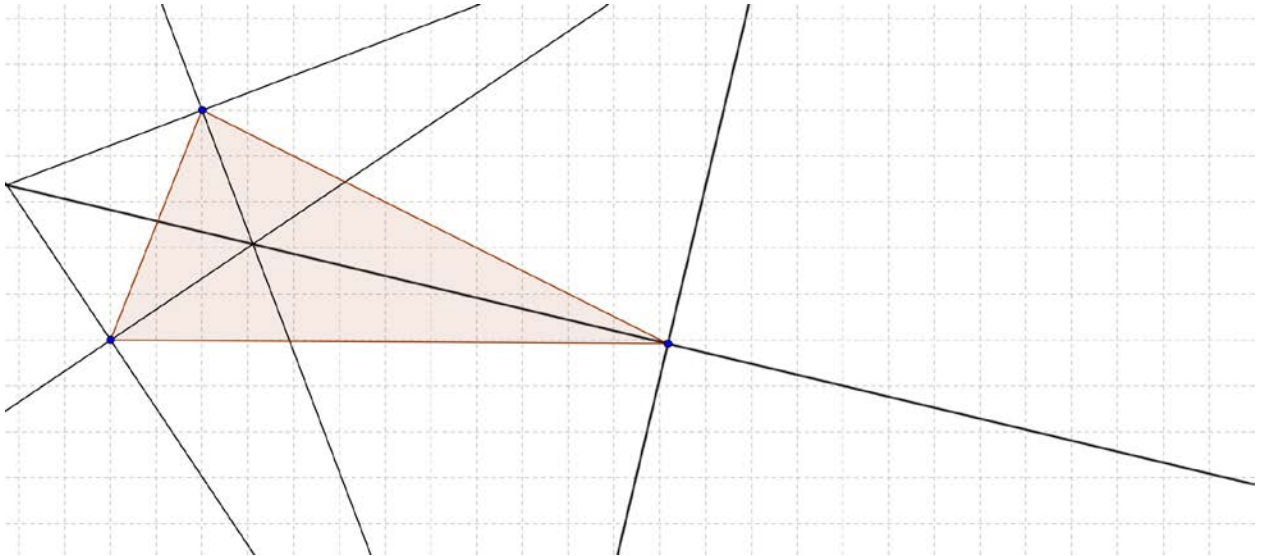

Georgia Department of Education
Georgia Standards of Excellence Framework
GSE Geometry • Unit 2

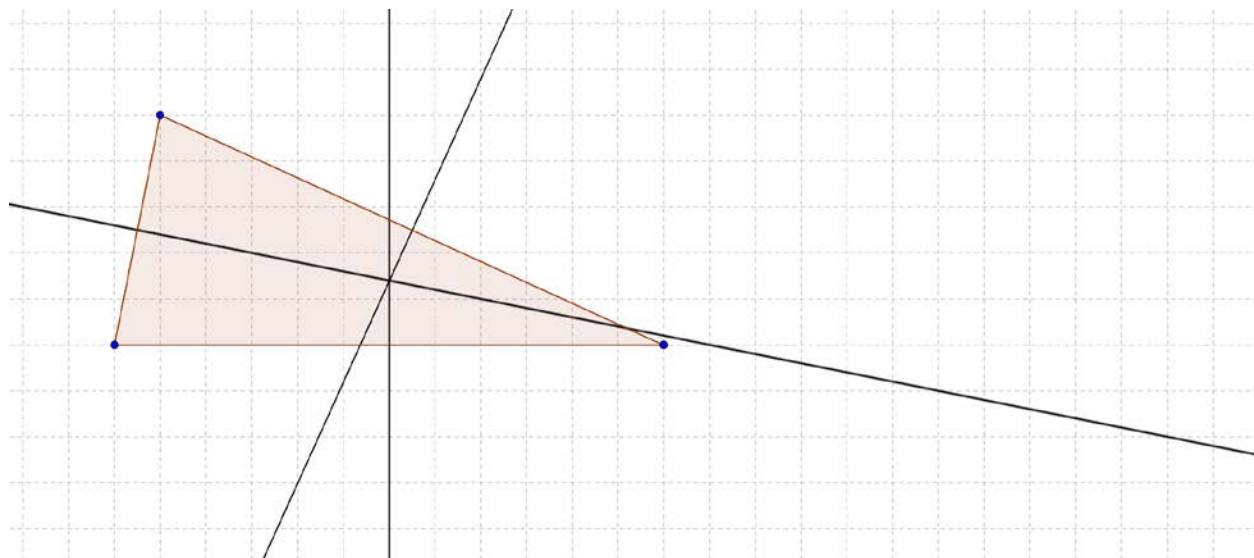

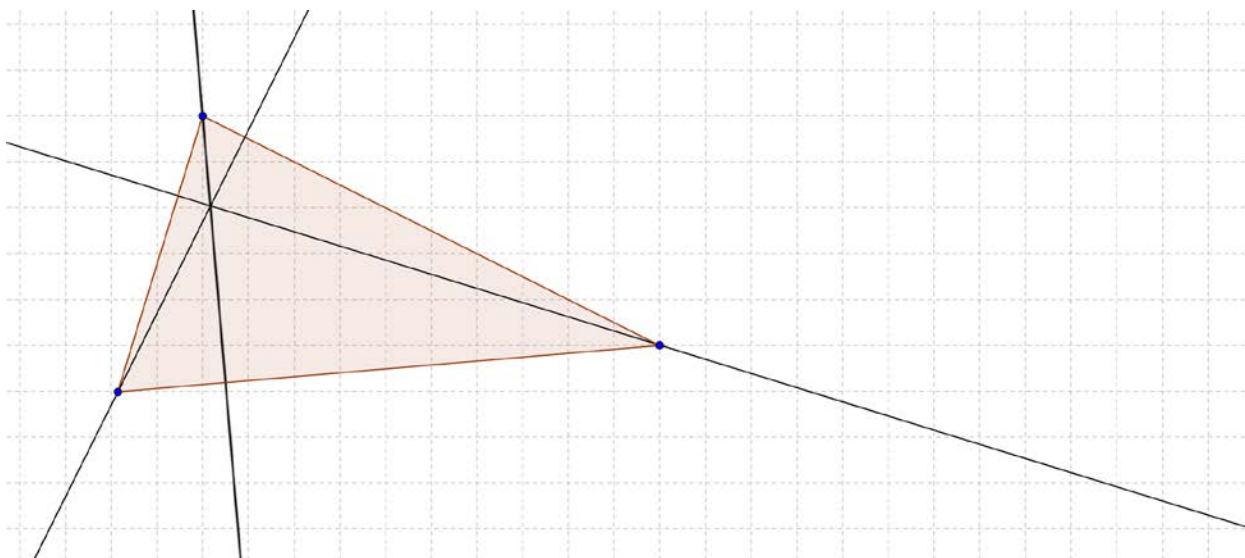
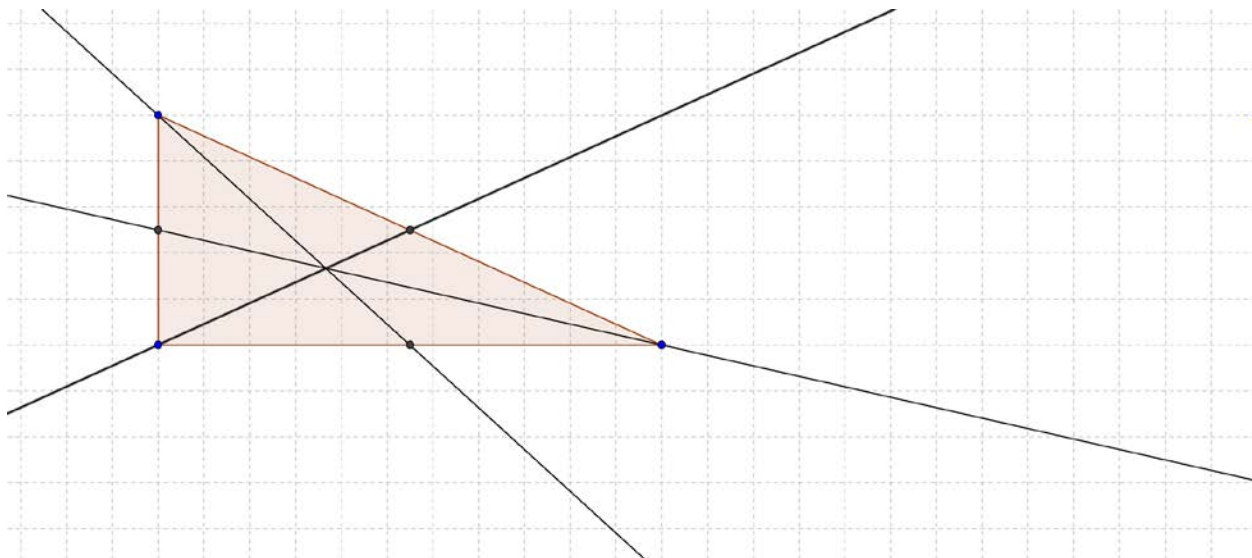

- 2.) I would use the median graph for the amusement park because it is in the middle of all the areas.
- 3.) I chose where the angles cross which is more to the left of the medians.
- 4.) Centroid is called this because it is basically the center of the triangle.
Incenter is called this because it is inside the triangle.
Circumcenter is called this because it is the center of a circle.
Orthocenter is called because “ortho” would relate to altitude, which is perpendicular to a side.
- 5.) I recommend the centroid.
- 6.) I would recommend that you build few roads but keep them by major roads, so that many people still come. Use the angle bisectors of major roads.

Centers of Triangles

Mathematical Goals

- Prove the medians of a triangle meet at a point.
- Bisect a segment and an angle.
- Construct perpendicular lines, including the perpendicular bisector of a line segment.

STANDARDS ADDRESSED IN THIS TASK

MGSE9-12.G.CO.10 Prove theorems about triangles. Theorems include: measures of interior angles of a triangle sum to 180 degrees; base angles of isosceles triangles are congruent; the segment joining midpoints of two sides of a triangle is parallel to the third side and half the length; the medians of a triangle meet at a point.

Standards for Mathematical Practice

1. **Make sense of problems and persevere in solving them** by requiring students to interpret and make meaning of a problem and find a logical starting point, and to monitor their progress and change their approach to solving the problem, if necessary.
2. **Reason abstractly and quantitatively** by requiring students to make sense of quantities and their relationships to one another in problem situations.
3. **Construct viable arguments and critique the reasoning of others** by engaging students on discussion of why they agree or disagree with responses, decide whether they make sense, and ask useful questions to clarify or improve the arguments.
4. **Model with mathematics** by expecting students to apply the mathematics concepts they know in order to solve problems arising in everyday situations, and reflect on whether the results are sensible for the given scenario.
5. **Use appropriate tools strategically** by expecting students to consider available tools when solving a mathematical problem. These tools might include pencil and paper, concrete models, a ruler, a protractor, a compass, a calculator, software, etc.
6. **Attend to precision** by requiring students to calculate efficiently and accurately; and to communicate precisely with others by using clear mathematical language to discuss their reasoning.
7. **Look for and make use of structure** by expecting students to apply rules, look for patterns and analyze structure.
8. **Look for and express regularity in repeated reasoning** by expecting students to understand broader applications and look for structure and general methods in similar situations.

Triangle Center:	Point of Concurrency of:	Significance of:
------------------	--------------------------	------------------

Georgia Department of Education
 Georgia Standards of Excellence Framework
GSE Geometry • Unit 2

Incenter	Angle bisectors	Center of inscribed circle Equidistant from the sides of the triangle
Circumcenter	Perpendicular bisectors	Center of the circumscribing circle Equidistant from the vertices of the
Orthocenter	Altitudes	
Centroid	Medians	Center of balance or gravity The distance from a vertex to the centroid is twice the distance from the centroid to the opposite side.

A developer plans to build an amusement park but wants to locate it within easy access of the three largest towns in the area as shown on the map below. The developer has to decide on the best location and is working with the ABC Construction Company to minimize costs wherever possible. No matter where the amusement park is located, roads will have to be built for access directly to the towns or to the existing highways.

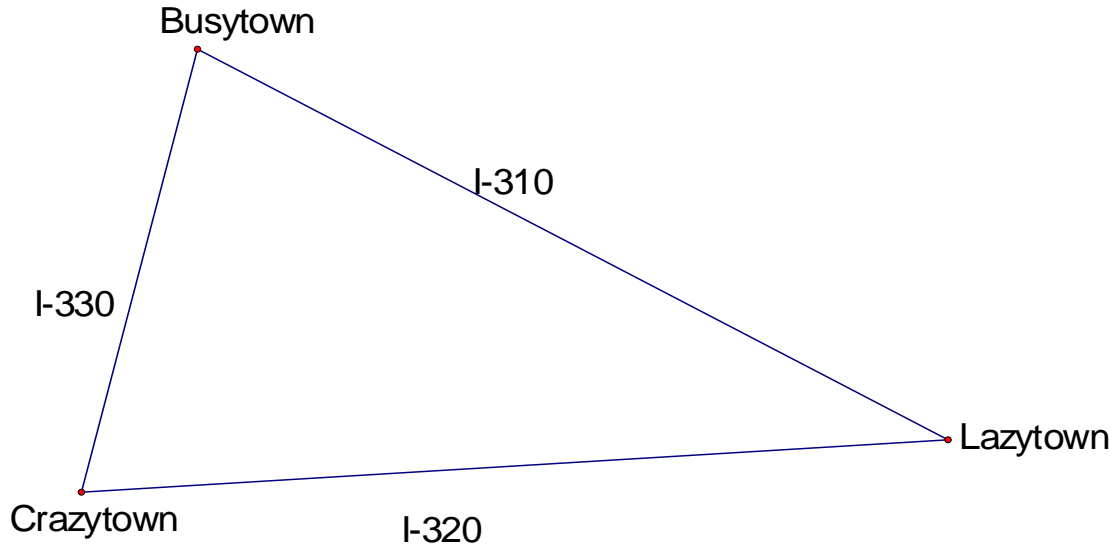

1. Just by looking at the map, choose the location that you think will be best for building the amusement park. Explain your thinking.
2. Now you will use some mathematical concepts to help you choose a location for the tower. Investigate the problem above by constructing the following:
 - a) all 3 medians of the triangle

- b) all 3 altitudes of the triangle
- c) all 3 angle bisectors of the triangle
- d) all 3 perpendicular bisectors of the triangle

You have four different kinds of tools at your disposal- patty paper, MIRA, compass and straight edge, and Geometer's Sketch Pad. Use a different tool for each of your constructions.

3. Choose a location for the amusement park based on the work you did in part 2. Explain why you chose this point.
4. How close is the point you chose in part 3, based on mathematics, to the point you chose by observation?

You have now discovered that each set of segments resulting from the constructions above always has a point of intersection. These four points of intersection are called the ***points of concurrency*** of a triangle.

The intersection point of the medians is called the ***centroid*** of the triangle.

The intersection point of the angle bisectors is called the ***incenter*** of the triangle.

The intersection point of the perpendicular bisectors is called the ***circumcenter*** of the triangle.

The intersection point of the altitudes is called the ***orthocenter*** of the triangle.

5. Can you give a reasonable guess as to why the specific names were given to each point of concurrency?
6. Which triangle center did you recommend for the location of the amusement park?
7. The president of the company building the park is concerned about the cost of building roads from the towns to the park. What recommendation would you give him? Write a memo to the president explaining your recommendation.

Constructing with Diagonals

Mathematical Goals

- Prove theorems pertaining to lines and angles.
- Prove theorems pertaining to triangles.
- Prove theorems pertaining to parallelograms.

STANDARDS ADDRESSED IN THIS TASK

MGSE9-12.G.CO.11 Prove theorems about parallelograms. Theorems include: opposite sides are congruent, opposite angles are congruent, the diagonals of a parallelogram bisect each other, and conversely, rectangles are parallelograms with congruent diagonals.

Standards for Mathematical Practice

- 1. Make sense of problems and persevere in solving them** by requiring students to interpret and make meaning of a problem and find a logical starting point, and to monitor their progress and change their approach to solving the problem, if necessary.
- 2. Reason abstractly and quantitatively** by requiring students to make sense of quantities and their relationships to one another in problem situations.
- 3. Construct viable arguments and critique the reasoning of others** by engaging students on discussion of why they agree or disagree with responses, decide whether they make sense, and ask useful questions to clarify or improve the arguments.
- 4. Model with mathematics** by expecting students to apply the mathematics concepts they know in order to solve problems arising in everyday situations, and reflect on whether the results are sensible for the given scenario.
- 5. Use appropriate tools strategically** by expecting students to consider available tools when solving a mathematical problem. These tools might include pencil and paper, concrete models, a ruler, a protractor, a compass, a calculator, software, etc.
- 6. Attend to precision** by requiring students to calculate efficiently and accurately; and to communicate precisely with others by using clear mathematical language to discuss their reasoning.
- 7. Look for and make use of structure** by expecting students to apply rules, look for patterns and analyze structure.
- 8. Look for and express regularity in repeated reasoning** by expecting students to understand broader applications and look for structure and general methods in similar situations.

Introduction

This task provides a guided discovery and investigation of the properties of quadrilaterals. Students will determine which quadrilateral(s) can be constructed based on specific information about the diagonals of the quadrilateral(s).

Sample proofs are given for each problem. The samples provided are not the only correct way these proofs can be written. Students should realize that proofs can be logically organized with differing orders of steps. They should also be given the opportunity to decide which type of proof they prefer writing.

Materials

There are many ways students can approach this task and the supplies will depend upon the method you choose for your students.

- Hands-on manipulatives like spaghetti noodles, straws, pipe cleaners, d-stix, etc. can be used to represent the lengths of the sides. Protractors will be needed to create the indicated angles between the sides and clay or play dough can be used to hold the sides together.
- Students can use compasses, straightedges and protractors to construct the triangles.
- Geometer's Sketchpad, or similar software, is a good tool to use in these investigations.

Construct two segments of different length that are perpendicular bisectors of each other. Connect the four end points to form a quadrilateral. What names can be used to describe the quadrilaterals formed using these constraints? Justify your answer.

Comment

Make sure the segments the students draw are of different lengths and both segments are bisected.

Solution

The quadrilateral is a parallelogram and a rhombus.

Sample proof:

Given: $\overline{AC} \perp \overline{BD}$, \overline{AC} bisects \overline{BD} , and \overline{BD} bisects \overline{AC}

Prove: $ABDC$ is a parallelogram and a rhombus.

Proof: $\overline{AC} \perp \overline{BD}$ is given, so, by definition $\angle AMB$, $\angle BMC$, $\angle CMD$ and $\angle DMA$ are right angles. All right angles are congruent to each other so $\angle AMB \cong \angle BMC \cong \angle CMD \cong \angle DMA$. By the definition of bisect, $\overline{AM} \cong \overline{MC}$ and $\overline{BM} \cong \overline{MD}$.

So, $\triangle ADM$, $\triangle ABM$, $\triangle CDM$, and $\triangle CBM$ are congruent by SAS. Using CPCTC, $\angle DAM \cong \angle BCM$ so $\overline{AD} \parallel \overline{CB}$ by the converse of the alternate interior angle theorem.

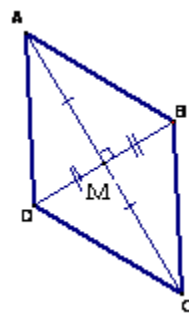

Similarly, using CPCTC, $\angle DCM \cong \angle BAM$ so $\overline{CD} \parallel \overline{BA}$ by the converse of the alternate interior angle theorem. Therefore, by definition $ABCD$ is a parallelogram. Also, \overline{AD} , \overline{AB} , \overline{CD} , and \overline{CB} are congruent by CPCTC. Therefore, $ABCD$ is a rhombus by the definition of a rhombus.

- Repeat #1 with two congruent segments. Connect the four end points to form a quadrilateral. What names can be used to describe the quadrilaterals formed using these constraints? Justify your answer.

Solution

The quadrilateral is a parallelogram, rhombus, rectangle and a square.

Sample proof:

Given: $\overline{AC} \perp \overline{BD}$, \overline{AC} bisects \overline{BD} , and \overline{BD} bisects \overline{AC}

Prove: $ABDC$ is a parallelogram and a rhombus.

Proof:

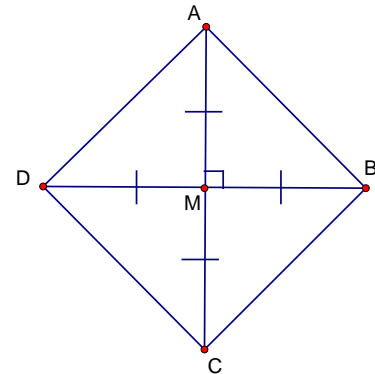

<u>Statement</u>	<u>Reason</u>
1. $\overline{AC} \perp \overline{BD}$ $\overline{AC} \cong \overline{BD}$ \overline{BD} bisects \overline{AC} \overline{AC} bisects \overline{BD}	1. Given
2. $\angle AMB$, $\angle BMC$, $\angle CMD$ and $\angle DMA$ are right angles	2. Definition of \perp
3. $\angle AMB \cong \angle BMC \cong \angle CMD \cong \angle DMA$	3. All right angles are congruent.
4. $\overline{AM} \cong \overline{MC}$ and $\overline{BM} \cong \overline{MD}$	4. Definition of bisect
5. $\overline{AM} \cong \overline{MC} \cong \overline{BM} \cong \overline{MD}$	5. $\overline{AC} \cong \overline{BD}$
6. $\triangle ADM \cong \triangle ABM \cong \triangle CDM \cong \triangle CBM$	6. SAS
7. $\angle DAM \cong \angle BCM$ $\angle DCM \cong \angle BAM$	7. CPCTC
8. $\overline{AD} \parallel \overline{CB}$ $\overline{CD} \parallel \overline{BA}$	8. Converse of the Alternate Interior Angles Theorem
9. <u>$ABCD$ is a parallelogram</u>	9. Definition of parallelogram
10. $\overline{AD} \cong \overline{AB} \cong \overline{CD} \cong \overline{CB}$	10. CPCTC
11. <u>$ABCD$ is a rhombus</u>	11. Definition of a rhombus
12. <u>$ABCD$ is a rectangle</u>	12. The diagonals of the parallelogram are congruent.
13. <u>$ABCD$ is a square</u>	13. The parallelogram is a rectangle with 4 congruent sides.

- Construct two segments that bisect each other but are not perpendicular. Connect the four end points to form a quadrilateral. What names can be used to describe the quadrilaterals formed using these constraints? Justify your answer.

Comment

Students can keep from making incorrect conjectures if they will exaggerate the shape of the figure they are exploring. They should not use segments that seem to be congruent and they should not make them look like they are perpendicular. If they are not careful in drawing this, it would be easy for them to think this figure would always be a rhombus or even a rectangle.

Solution

The quadrilateral is a parallelogram.

Sample proof:

Given: \overline{AC} bisects \overline{BD} , and \overline{BD} bisects \overline{AC}

Prove: $ABDC$ is a parallelogram.

Proof:

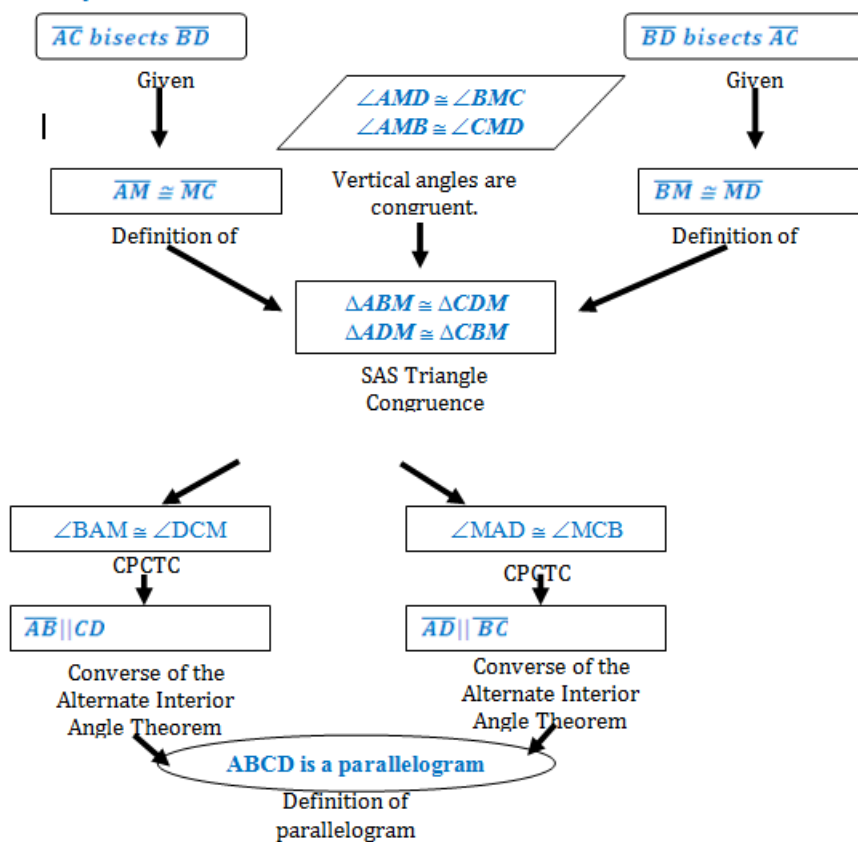
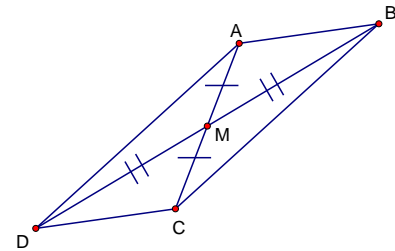

3. What if the two segments in #3 above are congruent in length? What type of quadrilateral is formed? What names can be used to

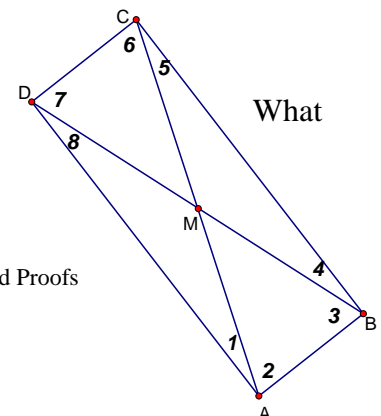

describe the quadrilaterals formed using these constraints? Justify your answer.

Solution

The quadrilateral is a parallelogram and a rectangle.

Sample proof:

Given: \overline{AC} bisects \overline{BD} , \overline{BD} bisects \overline{AC} , and $\overline{AC} \cong \overline{BD}$

Prove: $ABDC$ is a parallelogram and a rectangle.

Proof: We are given that \overline{AC} bisects \overline{BD} , \overline{BD} bisects \overline{AC} , and $\overline{AC} \cong \overline{BD}$. This means $\overline{AM} \cong \overline{MC} \cong \overline{BM} \cong \overline{MD}$. Since vertical angles are congruent $\angle DMA \cong \angle BMC$ and $\angle DMC \cong \angle BMA$. So, $\triangle DAM \cong \triangle BCM$ and $\triangle CDM \cong \triangle BAM$ by SAS. Using CPCTC, $\angle 6 \cong \angle 2$ and $\angle 4 \cong \angle 2$ which leads to $\overline{AB} \parallel \overline{CD}$ and $\overline{AD} \parallel \overline{BC}$ by the Converse of the Interior Angle Theorem. Since the opposite sides are parallel, by definition, $ABCD$ is a parallelogram. Using the Interior Angle Theorem the following pairs of angles are congruent: $\angle 7$ and $\angle 3$, $\angle 5$ and $\angle 1$. Since $\overline{AM} \cong \overline{MC} \cong \overline{BM} \cong \overline{MD}$, $\triangle DAM$, $\triangle BCM$, $\triangle CDM$, and $\triangle BAM$ are isosceles triangles. This means $\angle 1 \cong \angle 8$, $\angle 2 \cong \angle 3$, $\angle 4 \cong \angle 5$ and $\angle 6 \cong \angle 7$ by the Isosceles Base Angles Theorem. So, $\angle ABC \cong \angle BCD \cong \angle CDA \cong \angle DAB$ by the angle addition postulate. Since the sum of the angles in any quadrilateral is 360° and the 4 angles are congruent, each angle in the quadrilateral measures 90° , giving us four right angles. Therefore, $ABCD$ is a rectangle, since it is a parallelogram with 4 right angles and 2 pairs of congruent opposite sides.

4. Draw a segment and mark the midpoint. Now construct a segment that is perpendicular to the first segment at the midpoint but is not bisected by the original segment. Connect the four end points to form a quadrilateral. What names can be used to describe the quadrilaterals formed using these constraints? Justify your answer.

Comment

Make sure only one segment is bisected in the students' drawings. Encourage students to exaggerate the part of the drawing that is supposed to be different. If they draw two segments that appear to be congruent it is easy to draw incorrect conclusions. Students may be unfamiliar with the mathematical definition of a kite. It may be necessary to have them look up information about this figure.

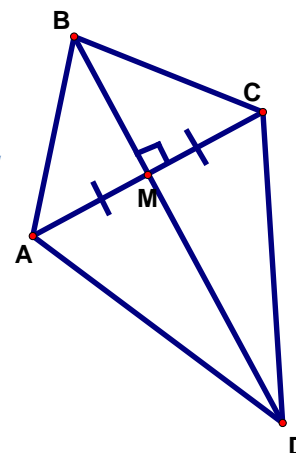

Solution

The quadrilateral is a kite.

Sample proof:

Given: \overline{AC} bisects \overline{BD} , \overline{BD} bisects \overline{AC} , and $\overline{AC} \perp \overline{BD}$

Prove: $ABDC$ is a parallelogram and a rectangle.

<i>Statement</i>	<i>Reason</i>
1. $\overline{AC} \perp \overline{BD}$ \overline{BD} bisects \overline{AC}	1. given
2. $\overline{AM} \cong \overline{MC}$	2. Definition of bisect
3. $\angle AMB, \angle BMC, \angle CMD$ and $\angle DMA$ are right angles	3. Definition of \perp
4. $\angle AMB \cong \angle BMC \cong \angle CMD \cong \angle DMA$	4. All right angles are congruent
5. $\overline{BM} \cong \overline{BM}, \overline{MD} \cong \overline{MD}$	5. Reflexive property
6. $\triangle AMB \cong \triangle CMB$ and $\triangle AMD \cong \triangle CMD$	6. SAS
7. $\overline{AB} \cong \overline{BC}$ and $\overline{AD} \cong \overline{DC}$	7. CPCTC
8. $ABCD$ is a kite	8. Definition of kite

5. In the above constructions you have been discovering the properties of the diagonals of each member of the quadrilateral family. Stop and look at each construction. Summarize any observations you can make about the special quadrilaterals you constructed. If there are any quadrilaterals that have not been constructed yet, investigate any special properties of their diagonals.

Comment

Quadrilaterals not investigated include trapezoids and isosceles trapezoids.

6. Complete the chart below by identifying the quadrilateral(s) for which the given condition is necessary.

Solution

Look closely for students' thoughts when they explain their reasoning. This should be written in their own words and doesn't have to be a proof. The explanations below are written in a manner similar to the way a student might explain their reasoning. All students should agree with the middle column but explanations may vary.

Georgia Department of Education
 Georgia Standards of Excellence Framework
GSE Geometry • Unit 2

Conditions	Quadrilateral(s)	Explain your reasoning
Diagonals are perpendicular.	<i>Rhombus Square Kite</i>	<i>This is always true of a rhombus, square and kite. But there are some parallelograms and rectangles that do not have perpendicular diagonals.</i>
Diagonals are perpendicular and only one diagonal is bisected.	<i>Kite</i>	<i>All parallelograms have diagonals that bisect each other so this can't be true for any of them. The diagonals are not bisected in an isosceles trapezoid so this would have to be a kite.</i>
Diagonals are congruent and intersect but are not perpendicular.	<i>Rectangle Isosceles Trapezoid</i>	<i>This is true for a rectangle but not a square. The square's diagonals are perpendicular. The isosceles trapezoid is special and this is true of that type of trapezoid.</i>
Diagonals bisect each other.	<i>Parallelogram Rectangle Rhombus Square</i>	<i>This is true of all parallelograms. This is not true of kites and isosceles trapezoids.</i>
Diagonals are perpendicular and bisect each other.	<i>Rhombus</i>	<i>This is true of rhombuses and is also true of squares. But unless we know the diagonals are congruent we don't know if it is a square.</i>
Diagonals are congruent and bisect each other.	<i>Rectangle</i>	<i>This is always true of a rectangle. But unless we know the diagonals are perpendicular we don't know if it is a square.</i>
Diagonals are congruent, perpendicular and bisect each other.	<i>Square</i>	<i>Only a square has all three of these properties. The rectangle's diagonals are not always perpendicular and the diagonals of rhombuses are not always congruent.</i>

7. As you add more conditions to describe the diagonals, how does it change the types of quadrilaterals possible? Why does this make sense?

Solution

As more restrictions are placed on the quadrilateral, fewer types of quadrilaterals meet all the restrictions.

8. Name each of the figures below using as many names as possible and state as many properties as you can about each figure.

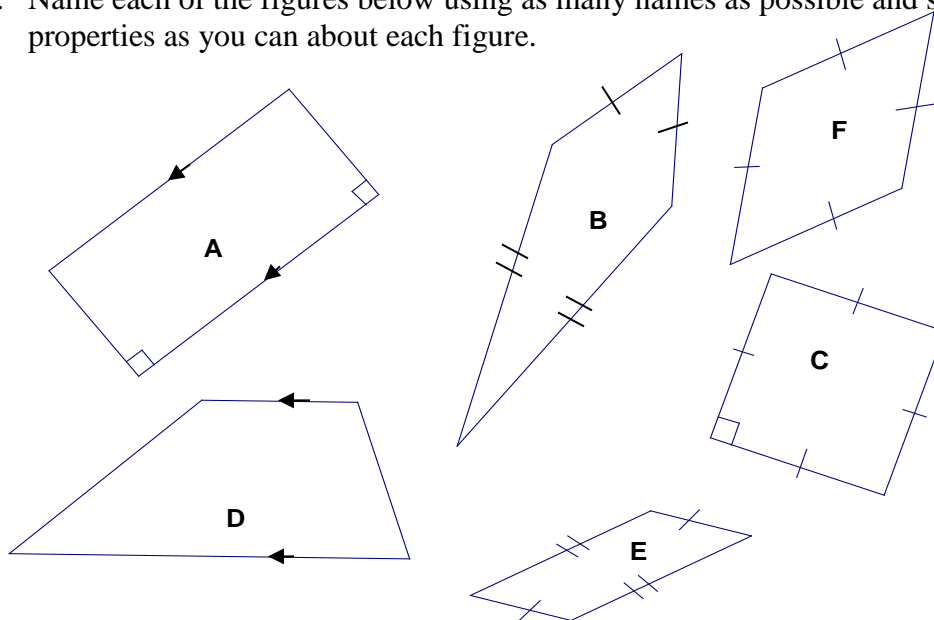

Solution

Answers may vary but they should include the properties listed below. Students may discover more properties than listed here. As long as they can prove it to always be true they should list as many properties as possible.

Figure	Names	Properties
A	<i>Parallelogram</i> <i>Rectangle</i>	<i>Opposite sides are congruent.</i> <i>Diagonals are congruent and bisect each other.</i>
B	<i>Kite</i>	<i>Diagonals are perpendicular.</i> <i>Angles between non-congruent sides are congruent to each other.</i> <i>Diagonal between congruent angles is bisected by the other diagonal.</i>
C	<i>Parallelogram</i> <i>Rectangle</i> <i>Rhombus</i> <i>Square</i>	<i>Diagonals bisect each other and are perpendicular.</i>
D	<i>Trapezoid</i>	<i>No specific properties.</i>
E	<i>Parallelogram</i>	<i>Diagonals bisect each other.</i>
F	<i>Parallelogram</i> <i>Rhombus</i>	<i>Diagonals bisect each other and are perpendicular.</i>

Georgia Department of Education
 Georgia Standards of Excellence Framework
 GSE Geometry • Unit 2

9. Identify the properties that are always true for the given quadrilateral by placing an X in the appropriate box.

Solutions

Property	Parallelogram	Rectangle	Rhombus	Square	Isosceles Trapezoid	Kite
Opposite sides are parallel.	X	X	X	X		
Only one pair of opposite sides is parallel.					X	
Opposite sides are congruent.	X	X	X	X		
Only one pair of opposite sides is congruent.					X	
Opposite angles are congruent.	X	X	X	X		
Only one pair of opposite angles is congruent.						X
Each diagonal forms 2 \cong triangles.	X	X	X	X	X	
Diagonals bisect each other.	X	X	X	X		
Diagonals are perpendicular.			X	X		X
Diagonals are congruent.		X		X	X	
Diagonals bisect vertex angles.			X	X		
All \angle s are right \angle s.		X		X		
All sides are congruent.			X	X		
Two pairs of consecutive sides are congruent.						X

Using the properties in the table above, list the **minimum** conditions necessary to prove that a quadrilateral is:

Solution

A few solutions are listed. Students may think of more. As long as they can prove it to always be true, they should list it.

- a. a parallelogram
opposite sides are parallel
-or
opposite sides are congruent
-or
diagonals bisect each other
- b. a rectangle
diagonals are congruent and bisect each other
-or
opposite sides are parallel and congruent
-or
opposite angles are congruent and diagonals are congruent
- c. a rhombus
diagonals are perpendicular and bisect each other
-or
opposite sides are congruent and diagonals bisect each other
- d. a square
diagonals are congruent, perpendicular and bisect each other
-or
opposite sides are congruent and diagonals are congruent and perpendicular
- e. a kite
diagonals are perpendicular and one diagonal is bisected
or
diagonals are perpendicular and two pairs of consecutive sides are congruent
- f. an isosceles trapezoid
only one pair of sides is parallel and diagonals are congruent

Constructing with Diagonals

Mathematical Goals

- Prove theorems pertaining to lines and angles.
- Prove theorems pertaining to triangles.
- Prove theorems pertaining to parallelograms.

STANDARDS ADDRESSED IN THIS TASK

MGSE9-12.G.CO.11 Prove theorems about parallelograms. Theorems include: opposite sides are congruent, opposite angles are congruent, the diagonals of a parallelogram bisect each other, and conversely, rectangles are parallelograms with congruent diagonals.

Standards for Mathematical Practice

1. **Make sense of problems and persevere in solving them** by requiring students to interpret and make meaning of a problem and find a logical starting point, and to monitor their progress and change their approach to solving the problem, if necessary.
2. **Reason abstractly and quantitatively** by requiring students to make sense of quantities and their relationships to one another in problem situations.
3. **Construct viable arguments and critique the reasoning of others** by engaging students on discussion of why they agree or disagree with responses, decide whether they make sense, and ask useful questions to clarify or improve the arguments.
4. **Model with mathematics** by expecting students to apply the mathematics concepts they know in order to solve problems arising in everyday situations, and reflect on whether the results are sensible for the given scenario.
5. **Use appropriate tools strategically** by expecting students to consider available tools when solving a mathematical problem. These tools might include pencil and paper, concrete models, a ruler, a protractor, a compass, a calculator, software, etc.
6. **Attend to precision** by requiring students to calculate efficiently and accurately; and to communicate precisely with others by using clear mathematical language to discuss their reasoning.
7. **Look for and make use of structure** by expecting students to apply rules, look for patterns and analyze structure.
8. **Look for and express regularity in repeated reasoning** by expecting students to understand broader applications and look for structure and general methods in similar situations.

Introduction

This task provides a guided discovery and investigation of the properties of quadrilaterals. Students will determine which quadrilateral(s) can be constructed based on specific information about the diagonals of the quadrilateral(s).

Sample proofs are given for each problem. The samples provided are not the only correct way these proofs can be written. Students should realize that proofs can be logically organized with differing orders of steps. They should also be given the opportunity to decide which type of proof they prefer writing.

Materials

There are many ways students can approach this task and the supplies will depend upon the method you choose for your students.

- Hands-on manipulatives like spaghetti noodles, straws, pipe cleaners, d-stix, etc. can be used to represent the lengths of the sides. Protractors will be needed to create the indicated angles between the sides and clay or play dough can be used to hold the sides together.
- Students can use compasses, straightedges and protractors to construct the triangles.
- Geometer's Sketchpad, Geogebra or similar software, is a good tool to use in these investigations.

-
1. Construct two segments of different length that are perpendicular bisectors of each other. Connect the four end points to form a quadrilateral. What names can be used to describe the quadrilaterals formed using these constraints? Justify your answer.
 2. Repeat #1 with two congruent segments. Connect the four end points to form a quadrilateral. What names can be used to describe the quadrilaterals formed using these constraints? Justify your answer.
 3. Construct two segments that bisect each other but are not perpendicular. Connect the four end points to form a quadrilateral. What names can be used to describe the quadrilaterals formed using these constraints? Justify your answer.
 4. What if the two segments in #3 above are congruent in length? What type of quadrilateral is formed? What names can be used to describe the quadrilaterals formed using these constraints? Justify your answer.
 5. Draw a segment and mark the midpoint. Now construct a segment that is perpendicular to the first segment at the midpoint but is not bisected by the original segment. Connect the four end points to form a quadrilateral. What names can be used to describe the quadrilaterals formed using these constraints? Justify your answer.
 6. In the above constructions you have been discovering the properties of the diagonals of each member of the quadrilateral family. Stop and look at each construction. Summarize any observations you can make about the special quadrilaterals you constructed. If there are any

Georgia Department of Education
 Georgia Standards of Excellence Framework
GSE Geometry • Unit 2

quadrilaterals that have not been constructed yet, investigate any special properties of their diagonals.

7. Complete the chart below by identifying the quadrilateral(s) for which the given condition is necessary.

Conditions	Quadrilateral(s)	Explain your reasoning
Diagonals are perpendicular.		
Diagonals are perpendicular and only one diagonal is bisected.		
Diagonals are congruent and intersect but are not perpendicular.		
Diagonals bisect each other.		
Diagonals are perpendicular and bisect each other.		
Diagonals are congruent and bisect each other.		
Diagonals are congruent, perpendicular and bisect each other.		

8. As you add more conditions to describe the diagonals, how does it change the types of quadrilaterals possible? Why does this make sense?

Georgia Department of Education
 Georgia Standards of Excellence Framework
GSE Geometry • Unit 2

9. Name each of the figures below using as many names as possible and state as many properties as you can about each figure.

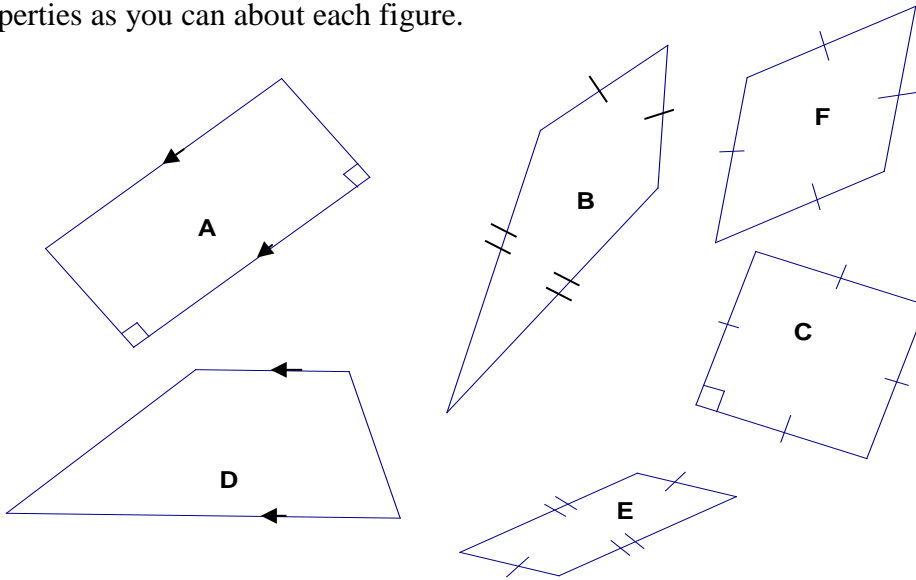

Figure	Names	Properties
A		
B		
C		
D		
E		
F		

10. Identify the properties that are always true for the given quadrilateral by placing an X in the appropriate box.

Georgia Department of Education
 Georgia Standards of Excellence Framework
 GSE Geometry • Unit 2

Property	Parallelogram	Rectangle	Rhombus	Square	Isosceles Trapezoid	Kite
Opposite sides are parallel.						
Only one pair of opposite sides is parallel.						
Opposite sides are congruent.						
Only one pair of opposite sides is congruent.						
Opposite angles are congruent.						
Only one pair of opposite angles is congruent.						
Each diagonal forms 2 \cong triangles.						
Diagonals bisect each other.						
Diagonals are perpendicular.						
Diagonals are congruent.						
Diagonals bisect vertex angles.						
All \angle s are right \angle s.						
All sides are congruent.						
Two pairs of consecutive sides are congruent.						

11. Using the properties in the table above, list the **minimum** conditions necessary to prove that a quadrilateral is:

- a. a parallelogram

- b. a rectangle

- c. a rhombus

Georgia Department of Education
Georgia Standards of Excellence Framework
GSE Geometry • Unit 2

d. a square

e. a kite

f. an isosceles trapezoid

Formative Assessment Lesson: Evaluating Statements about Length & Area

Source: *Formative Assessment Lesson Materials from Mathematics Assessment Project*

<http://map.mathshell.org/materials/download.php?fileid=675>

ESSENTIAL QUESTION:

- Why are two areas equal or not equal?

TASK COMMENTS:

Tasks and lessons from the Mathematics Assessment Project are specifically designed to help teachers effectively formatively assess their students. The way the tasks and lessons are designed gives the teacher a clear understanding of what the students are able to do and not do. Within the lesson, teachers will find suggestions and question prompts that will help guide students towards understanding. For more information access the MAP website:

<http://www.map.mathshell.org/materials/background.php?subpage=formative>

The task, *Evaluating Statements about Length & Area*, is a Formative Assessment Lesson (FAL) that can be found at the website:

<http://map.mathshell.org/materials/lessons.php?taskid=212&subpage=concept>

The FAL document provides a clear lesson design, from the opening of the lesson to the closing of the lesson.

The PDF version of the task can be found at the link below:

<http://map.mathshell.org/materials/download.php?fileid=675>

STANDARDS ADDRESSED IN THIS TASK:

Prove geometric theorems

MGSE9-12.G.CO.9 Prove theorems about lines and angles. Theorems include: vertical angles are congruent; when a transversal crosses parallel lines, alternate interior angles are congruent and corresponding angles are congruent; points on a perpendicular bisector of a line segment are exactly those equidistant from the segment's endpoints.

MGSE9-12.G.CO.10 Prove theorems about triangles. Theorems include: measures of interior angles of a triangle sum to 180 degrees; base angles of isosceles triangles are congruent; the segment joining midpoints of two sides of a triangle is parallel to the third side and half the length; the medians of a triangle meet at a point.

MGSE9-12.G.CO.11 Prove theorems about parallelograms. Theorems include: opposite sides are congruent, opposite angles are congruent, the diagonals of a parallelogram bisect each other, and conversely, rectangles are parallelograms with congruent diagonals.

Standards for Mathematical Practice

This lesson uses all of the practices with emphasis on:

- 2. Reason abstractly and quantitatively** by requiring students to make sense of quantities and their relationships to one another in problem situations.
- 3. Construct viable arguments and critique the reasoning of others** by engaging students on discussion of why they agree or disagree with responses, decide whether they make sense, and ask useful questions to clarify or improve the arguments.

Formative Assessment Lesson: Floor Pattern

Source: *Balanced Assessment Materials from Mathematics Assessment Project*
<http://www.map.mathshell.org/materials/download.php?fileid=768>

ESSENTIAL QUESTION:

- How do you prove that a quadrilateral is a parallelogram?

TASK COMMENTS:

Tasks and lessons from the Mathematics Assessment Project are specifically designed to help teachers effectively formatively assess their students. The way the tasks and lessons are designed gives the teacher a clear understanding of what the students are able to do and not do. Within the lesson, teachers will find suggestions and question prompts that will help guide students towards understanding. For more information access the MAP website:

<http://www.map.mathshell.org/materials/background.php?subpage=summative>

The task, *Floor Pattern*, is a Mathematics Assessment Project Assessment Task that can be found at the

website: <http://www.map.mathshell.org/materials/tasks.php?taskid=258&subpage=apprentice>

The PDF version of the task can be found at the link below:

<http://www.map.mathshell.org/materials/download.php?fileid=768>

The scoring rubric can be found at the following link:

<http://www.map.mathshell.org/materials/download.php?fileid=769>

STANDARDS ADDRESSED IN THIS TASK:

Prove geometric theorems

MGSE9-12.G.CO.9 Prove theorems about lines and angles. Theorems include: vertical angles are congruent; when a transversal crosses parallel lines, alternate interior angles are congruent and corresponding angles are congruent; points on a perpendicular bisector of a line segment are exactly those equidistant from the segment's endpoints.

MGSE9-12.G.CO.10 Prove theorems about triangles. Theorems include: measures of interior angles of a triangle sum to 180 degrees; base angles of isosceles triangles are congruent; the segment joining midpoints of two sides of a triangle is parallel to the third side and half the length; the medians of a triangle meet at a point.

MGSE9-12.G.CO.11 Prove theorems about parallelograms. Theorems include: opposite sides are congruent, opposite angles are congruent, the diagonals of a parallelogram bisect each other, and conversely, rectangles are parallelograms with congruent diagonals.

Standards for Mathematical Practice

This task uses all of the practices with emphasis on:

- 3. Construct viable arguments and critique the reasoning of others** by engaging students on discussion of why they agree or disagree with responses, decide whether they make sense, and ask useful questions to clarify or improve the arguments
- 7. Look for and make use of structure** by expecting students to apply rules, look for patterns and analyze structure.

Dilations in the Coordinate Plane

Adapted from Stretching and Shrinking: Similarity, *Connected Mathematics*, Dale Seymour Publications

Mathematical Goals

- Given a center and a scale factor, verify experimentally, that when dilating a figure in a coordinate plane, a segment of the pre-image that does not pass through the center of the dilation, is parallel to its image when the dilation is performed.
- Given a center and a scale factor, verify experimentally, that when performing dilations of a line segment, the pre-image, the segment which becomes the image is longer or shorter based on the ratio given by the scale factor.
- Use the idea of dilation transformations to develop the definition of similarity.

STANDARDS ADDRESSED IN THIS TASK

MGSE9-12.G.SRT.1 Verify experimentally the properties of dilations given by a center and a scale factor.

- a. The dilation of a line not passing through the center of the dilation results in a parallel line and leaves a line passing through the center unchanged.
- b. The dilation of a line segment is longer or shorter according to the ratio given by the scale factor.

MGSE9-12.G.SRT.2 Given two figures, use the definition of similarity in terms of similarity transformations to decide if they are similar; explain, using similarity transformations, the meaning of similarity for triangles as the equality of all corresponding pairs of angles and the proportionality of all corresponding pairs of sides.

Standards for Mathematical Practice

- 1. Make sense of problems and persevere in solving them** by requiring students to interpret and make meaning of a problem and find a logical starting point, and to monitor their progress and change their approach to solving the problem, if necessary.
- 4. Model with mathematics** by expecting students to apply the mathematics concepts they know in order to solve problems arising in everyday situations, and reflect on whether the results are sensible for the given scenario.
- 7. Look for and make use of structure** by expecting students to apply rules, look for patterns and analyze structure.
- 8. Look for and express regularity in repeated reasoning** by expecting students to understand broader applications and look for structure and general methods in similar situations.

Common Student Misconceptions

1. Students may not realize that similarities preserve shape, but not size. Angle measures stay the same, but side lengths change by a constant scale factor.

2. Students may incorrectly apply the scale factor. For example students will multiply instead of divide with a scale factor that reduces a figure or divide instead of multiply when enlarging a figure.

Introduction

In this task, students will find rules to describe transformations in the coordinate plane. Rules of the form (nx, ny) transform a figure in the plane into a similar figure in the plane. This transformation is called dilation with the center of dilation at the origin. The coefficient of x and y is the scale factor. Adding a number to x or y results in a translation of the original figure but does not affect the size. Thus, a more general rule for dilations centered at the origin is $(nx + a, ny + b)$. Teachers should support good student dialogue and take advantage of comments and questions to help guide students into correct mathematical thinking. Students will also observe that congruence is a special case of similarity ($n=1$). Congruent figures have the same size and shape.

Materials

- graph paper
- colored pencils

Plot the ordered pairs given in the table to make six different figures. Draw each figure on a separate sheet of graph paper. Connect the points with line segments as follows:

- For Set 1, connect the points in order. Connect the last point in the set to the first point in the set.
- For Set 2, connect the points in order. Connect the last point in the set to the first point in the set.
- For Set 3, connect the points in order. Do not connect the last point in the set to the first point in the set.
- For Set 4, make a dot at each point (do not connect the dots).

Georgia Department of Education
 Georgia Standards of Excellence Framework
GSE Geometry • Unit 2

Figure 1	Figure 2	Figure 3	Figure 4	Figure 5	Figure 6
Set 1	Set 1	Set 1	Set 1	Set 1	Set 1
(6, 4)	(12, 8)	(18, 4)	(18, 12)	(6, 12)	(8, 6)
(6, -4)	(12, -8)	(18, -4)	(18, -12)	(6, -12)	(8, -2)
(-6, -4)	(-12, -8)	(-18, -4)	(-18, -12)	(-6, -12)	(-4, -2)
(-6, 4)	(-12, 8)	(-18, 4)	(-18, 12)	(-6, 12)	(-4, 6)
Set 2	Set 2	Set 2	Set 2	Set 2	Set 2
(1, 1)	(2, 2)	(3, 1)	(3, 3)	(1, 3)	(3, 3)
(1, -1)	(2, -2)	(3, -1)	(3, -3)	(1, -3)	(3, 1)
(-1, -1)	(-2, -2)	(-3, -1)	(-3, -3)	(-1, -3)	(1, 1)
(-1, 1)	(-2, 2)	(-3, 1)	(-3, 3)	(-1, 3)	(1, 3)
Set 3	Set 3	Set 3	Set 3	Set 3	Set 3
(4, -2)	(8, -4)	(12, -2)	(12, -6)	(4, -6)	(6, 0)
(3, -3)	(6, -6)	(9, -3)	(9, -9)	(3, -9)	(5, -1)
(-3, -3)	(-6, -6)	(-9, -3)	(-9, -9)	(-3, -9)	(-1, -1)
(-4, -2)	(-8, -4)	(-12, -2)	(-12, -6)	(-4, -6)	(-2, 0)
Set 4	Set 4	Set 4	Set 4	Set 4	Set 4
(4, 2)	(8, 4)	(12, 2)	(12, 6)	(4, 6)	(6, 4)
(-4, 2)	(-8, 4)	(-12, 2)	(-12, 6)	(-4, 6)	(-2, 4)

The scale used on the x - and y -axes in the figures below is 2 units. Each square is 4 square units (2×2).

Figure 1:

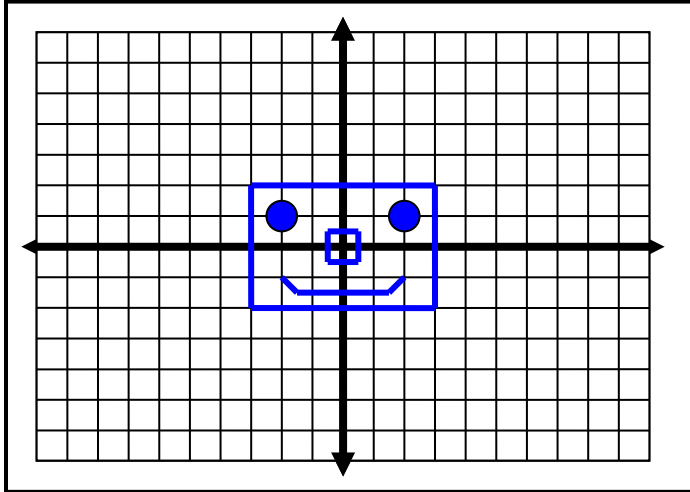

Figure 2:

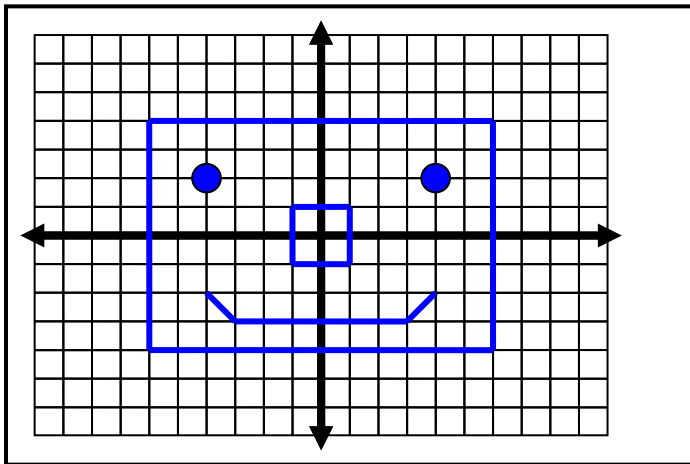

Figure 3:

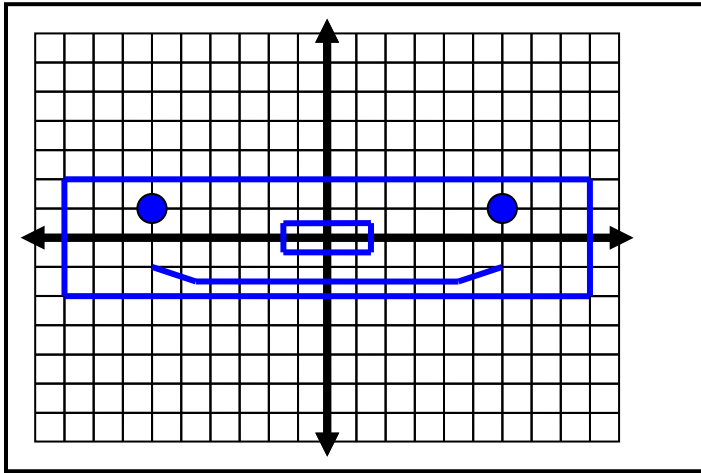

Figure 4:

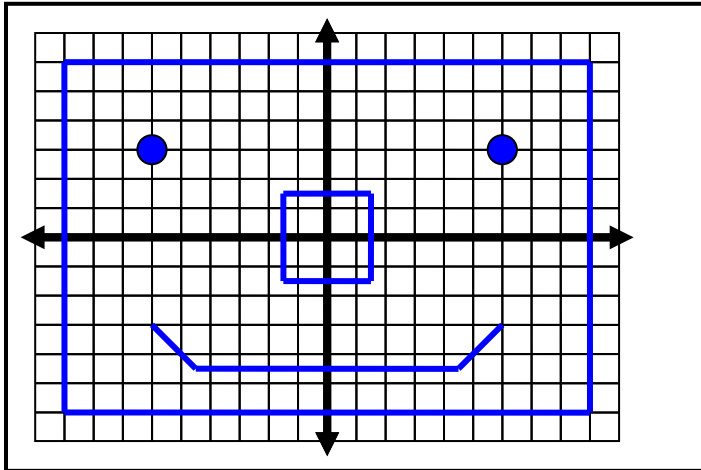

Figure 5:

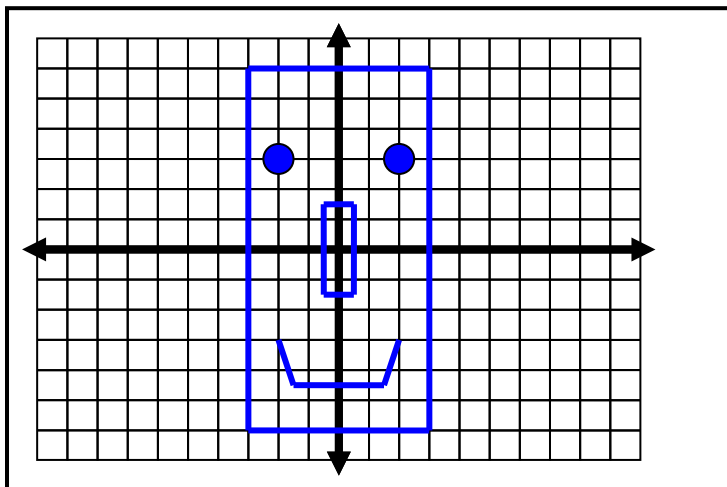
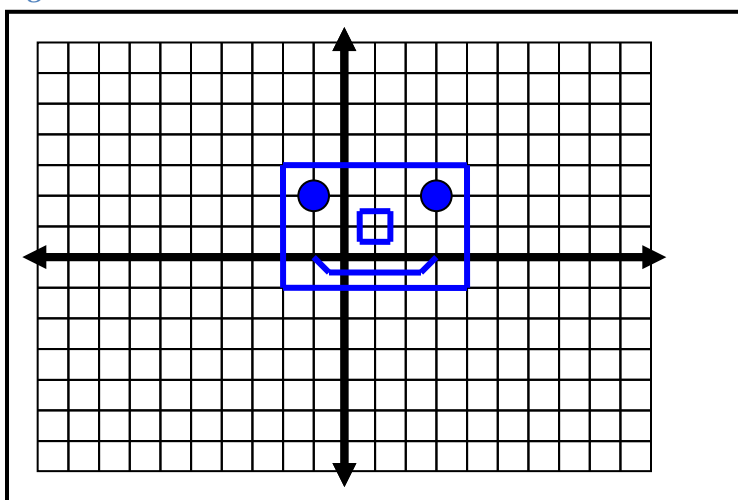

Figure 6:



After drawing the six figures, compare Figure 1 to each of the other figures and answer the following questions.

1. Which figures are similar? Use the definition of similar figures to justify your response.

Figures 1, 2, 4 and 6 are similar. Students may observe visually that these figures have the same shape but are different sizes (except for Figure 6). Figure 6 is congruent to Figure 1. Note that congruence is a special case of similarity – figures have the same size and shape. Figures 3 and 5 are longer (or taller) and skinnier. Students may also notice that corresponding angles are equal for all figures. The scale factor from Figure 1 to Figure 2 is 2. The scale factor from Figure 1 to Figure 4 is 3. The side lengths of Figure 2 are twice the side lengths of Figure 1 and the side lengths of Figure 4 are three times the side

lengths of Figure 1. The scale factor from Figure 1 to Figure 6 is 1 because it is congruent to Figure 1. In Figures 3 and 5, one dimension increases by a factor of 3 and the other does not.

2. Describe any similarities and/or differences between Figure 1 and each of the similar figures.
 - Describe how corresponding sides compare.
 - Describe how corresponding angles compare.

Figure 2 is an enlargement of Figure 1. The figures have the same shape but different sizes.

The ratio of the lengths of the corresponding sides is 1 to 2.

The corresponding angles are equal in measure.

Figure 4 is an enlargement of Figure 1. The figures have the same shape but different sizes. The ratio of the lengths of the corresponding sides is 1 to 3. The corresponding angles are equal in measure.

Figure 6 is the same shape and size as Figure 1. Figure 1 is shifted (i.e., translated) up and to the right to get Figure 6. The ratio of the lengths of the corresponding sides is 1 to 1. The corresponding angles are equal in measure.

3. How do the coordinates of each similar figure compare to the coordinates of Figure 1? Write general rules for making the similar figures.

Figure 2: Both the x and y coordinates are multiplied by 2. $(2x, 2y)$

Figure 4: Both the x and y coordinates are multiplied by 3. $(3x, 3y)$

Figure 6: Two is added to both the x and y coordinates. $(x + 2, y + 2)$

4. Is having the same angle measurement enough to make two figures similar? Why or why not?

No. All angles of the figures (except angles of the smiles) have the same angle measures, but the figures are not similar. Figures 3 and 5 are long (or tall) and skinny, unlike Figure 1.

5. What would be the effect of multiplying each of the coordinates in Figure 1 by $\frac{1}{2}$?

The figure would shrink and the lengths of the sides would be half as long.

6. Create a similar Figure 7 to Figure 1 where the center of dilation is not the origin but $(-6, -4)$ instead. Also Figure 7 is twice as big as Figure 1. What are the sets of points used to create Figure 7?

Set 1: $(18, 12)$, $(18, -4)$, $(-6, -4)$, $(-6, 12)$

Georgia Department of Education
Georgia Standards of Excellence Framework
GSE Geometry • Unit 2

Set 2: (8, 6), (8, 2), (4, 2), (4, 6)

Set 3: (14, 0), (12, -2), (0, -2), (-2, 0)

Set 4: (14, 8), (-2, 8)

Dilations in the Coordinate Plane

Adapted from *Stretching and Shrinking: Similarity*, *Connected Mathematics*, Dale Seymour Publications

Mathematical Goals

- Given a center and a scale factor, verify experimentally, that when dilating a figure in a coordinate plane, a segment of the pre-image that does not pass through the center of the dilation, is parallel to its image when the dilation is performed.
- Given a center and a scale factor, verify experimentally, that when performing dilations of a line segment, the pre-image, the segment which becomes the image is longer or shorter based on the ratio given by the scale factor.
- Use the idea of dilation transformations to develop the definition of similarity.

STANDARDS ADDRESSED IN THIS TASK

MGSE9-12.G.SRT.1 Verify experimentally the properties of dilations given by a center and a scale factor.

- a. The dilation of a line not passing through the center of the dilation results in a parallel line and leaves a line passing through the center unchanged.
- b. The dilation of a line segment is longer or shorter according to the ratio given by the scale factor.

MGSE9-12.G.SRT.2 Given two figures, use the definition of similarity in terms of similarity transformations to decide if they are similar; explain, using similarity transformations, the meaning of similarity for triangles as the equality of all corresponding pairs of angles and the proportionality of all corresponding pairs of sides.

Standards for Mathematical Practice

- 1. Make sense of problems and persevere in solving them** by requiring students to interpret and make meaning of a problem and find a logical starting point, and to monitor their progress and change their approach to solving the problem, if necessary.
- 4. Model with mathematics** by expecting students to apply the mathematics concepts they know in order to solve problems arising in everyday situations, and reflect on whether the results are sensible for the given scenario.
- 7. Look for and make use of structure** by expecting students to apply rules, look for patterns and analyze structure.
- 8. Look for and express regularity in repeated reasoning** by expecting students to understand broader applications and look for structure and general methods in similar situations.

Georgia Department of Education
 Georgia Standards of Excellence Framework
GSE Geometry • Unit 2

Plot the ordered pairs given in the table to make six different figures. Draw each figure on a separate sheet of graph paper. Connect the points with line segments as follows:

- For Set 1, connect the points in order. Connect the last point in the set to the first point in the set.
- For Set 2, connect the points in order. Connect the last point in the set to the first point in the set.
- For Set 3, connect the points in order. Do not connect the last point in the set to the first point in the set.
- For Set 4, make a dot at each point (do not connect the dots).

Figure 1	Figure 2	Figure 3	Figure 4	Figure 5	Figure 6
Set 1	Set 1	Set 1	Set 1	Set 1	Set 1
(6, 4)	(12, 8)	(18, 4)	(18, 12)	(6, 12)	(8, 6)
(6, -4)	(12, -8)	(18, -4)	(18, -12)	(6, -12)	(8, -2)
(-6, -4)	(-12, -8)	(-18, -4)	(-18, -12)	(-6, -12)	(-4, -2)
(-6, 4)	(-12, 8)	(-18, 4)	(-18, 12)	(-6, 12)	(-4, 6)
Set 2	Set 2	Set 2	Set 2	Set 2	Set 2
(1, 1)	(2, 2)	(3, 1)	(3, 3)	(1, 3)	(3, 3)
(1, -1)	(2, -2)	(3, -1)	(3, -3)	(1, -3)	(3, 1)
(-1, -1)	(-2, -2)	(-3, -1)	(-3, -3)	(-1, -3)	(1, 1)
(-1, 1)	(-2, 2)	(-3, 1)	(-3, 3)	(-1, 3)	(1, 3)
Set 3	Set 3	Set 3	Set 3	Set 3	Set 3
(4, -2)	(8, -4)	(12, -2)	(12, -6)	(4, -6)	(6, 0)
(3, -3)	(6, -6)	(9, -3)	(9, -9)	(3, -9)	(5, -1)
(-3, -3)	(-6, -6)	(-9, -3)	(-9, -9)	(-3, -9)	(-1, -1)
(-4, -2)	(-8, -4)	(-12, -2)	(-12, -6)	(-4, -6)	(-2, 0)
Set 4	Set 4	Set 4	Set 4	Set 4	Set 4
(4, 2)	(8, 4)	(12, 2)	(12, 6)	(4, 6)	(6, 4)
(-4, 2)	(-8, 4)	(-12, 2)	(-12, 6)	(-4, 6)	(-2, 4)

After drawing the six figures, compare Figure 1 to each of the other figures and answer the following questions.

1. Which figures are similar? Use the definition of similar figures to justify your response.

2. Describe any similarities and/or differences between Figure 1 and each of the similar figures.
 - Describe how corresponding sides compare.
 - Describe how corresponding angles compare.

3. How do the coordinates of each similar figure compare to the coordinates of Figure 1? Write general rules for making the similar figures.

4. Is having the same angle measurement enough to make two figures similar? Why or why not?

5. What would be the effect of multiplying each of the coordinates in Figure 1 by $\frac{1}{2}$?

6. Create a similar Figure 7 to Figure 1 where the center of dilation is not the origin but $(-6, -4)$ instead. Also Figure 7 is twice as big as Figure 1. What are the sets of points used to create Figure 7?

Similar Triangles

Mathematical Goals

- Discover the relationships that exist between similar figures using the scale factors, length ratios, and area ratios

STANDARDS ADDRESSED IN THIS TASK

MGSE9-12.G.SRT.1 Verify experimentally the properties of dilations given by a center and a scale factor.

- a. The dilation of a line not passing through the center of the dilation results in a parallel line and leaves a line passing through the center unchanged.
- b. The dilation of a line segment is longer or shorter according to the ratio given by the scale factor.

MGSE9-12.G.SRT.2 Given two figures, use the definition of similarity in terms of similarity transformations to decide if they are similar; explain, using similarity transformations, the meaning of similarity for triangles as the equality of all corresponding pairs of angles and the proportionality of all corresponding pairs of sides.

MGSE9-12.G.SRT.3 Use the properties of similarity transformations to establish the AA criterion for two triangles to be similar.

Standards for Mathematical Practice

- 1. Make sense of problems and persevere in solving them** by requiring students to interpret and make meaning of a problem and find a logical starting point, and to monitor their progress and change their approach to solving the problem, if necessary.
- 2. Reason abstractly and quantitatively** by requiring students to make sense of quantities and their relationships to one another in problem situations.
- 4. Model with mathematics** by expecting students to apply the mathematics concepts they know in order to solve problems arising in everyday situations, and reflect on whether the results are sensible for the given scenario.
- 8. Look for and express regularity in repeated reasoning** by expecting students to understand broader applications and look for structure and general methods in similar situations.

Common Student Misconception

Some students often do not list the vertices of similar triangles in order. However, the order in which vertices are listed is preferred and especially important for similar triangles so that proportional sides can be correctly identified.

Introduction

In this task, students will discover the relationships that exist between similar figures using the scale factors, length ratios, and area ratios. Teachers should support good student dialogue and take advantage of comments and questions to help guide students into correct mathematical thinking.

Materials

- graph paper
 - colored pencils
-

The sketch below shows two triangles, $\triangle ABC$ and $\triangle EFG$. $\triangle ABC$ has an area of 12 square units, and its base (AB) is equal to 8 units. The base of $\triangle EFG$ is equal to 24 units.

Students need to realize that the scale factor is 3 and that it is applied to both the base and height, so that the area increases by a factor of 9.

- a. How do you know that the triangles are similar?

The triangles are similar because three pairs of corresponding angles are congruent. This is because when two pairs of corresponding angles are congruent in a triangle, the third pair must also be congruent. Students should be questioned to develop this understanding. Note that in triangles, having the same angle measures is enough to make two triangles similar. This could be demonstrated with Geometer's Sketchpad.

- b. Name the pairs of corresponding sides and the pairs of corresponding angles. How are the corresponding sides related and how are the corresponding angles related? Why is this true?

*AB and EF; BC and FG; AC and EG are the corresponding sides
 $\angle B$ and $\angle F$; $\angle C$ and $\angle G$; $\angle A$ and $\angle E$ are the corresponding angles*

$$\frac{AB}{EF} = \frac{BC}{FG} = \frac{AC}{EG}$$

$$m\angle B = \angle F; m\angle C = m\angle G; m\angle A = m\angle E$$

These relationships are true because the triangles are similar.

- c. What is the area of $\triangle EFG$? Explain your reasoning.

Solution Method 1 -- The scale factor for similar triangles ABC and EFG is 3 since the ratio of the bases is 24 to 8. In similar triangles, the ratio of the areas is the square of the scale factor, so the ratio of the area of $\triangle EFG$ to the area of $\triangle ABC$ is 9. Therefore, the area of $\triangle EFG$ is 12×9 or 108 square units.

Solution Method 2 -- We can find the length of the altitude of $\triangle ABC$ by using the area formula.

$$\begin{aligned} A &= \frac{1}{2}bh \\ 12 &= \frac{1}{2}(8)h \\ 12 &= 4h \end{aligned}$$

$$3 = h$$

The altitude of $\triangle EFG$ is 3 times the altitude of $\triangle ABC$, so the length of the altitude of $\triangle EFG$ is 9. [Note to teachers: Students should verify that the length of the altitude increases by the same scale factor as the corresponding sides of similar triangles. This could be done with Geometer's Sketchpad.]

Using the area formula,

$$A = \frac{1}{2} bh$$

$$A = \frac{1}{2} (24)(9)$$

$$A = (12)(9)$$

$$A = 108$$

- d. What is the relationship between the area of $\triangle ABC$ and the area of $\triangle EFG$? What is the relationship between the scale factor and the ratio of the areas of the two triangles? Use an area formula to justify your answer algebraically.

The area of $\triangle EFG$ is nine times the area of $\triangle ABC$, but the side lengths of $\triangle EFG$ are three times the corresponding side lengths of $\triangle ABC$. In the area formula, the scale factor of 3 must be applied to both the base and height. So the area of $\triangle ABC$ is multiplied by 9.

$$\text{Area of } \triangle ABC = \frac{1}{2} bh$$

$$\text{Area of } \triangle EFG = \frac{1}{2} (3b)(3h)$$

$$\text{Area of } \triangle EFG = 9\left(\frac{1}{2} bh\right)$$

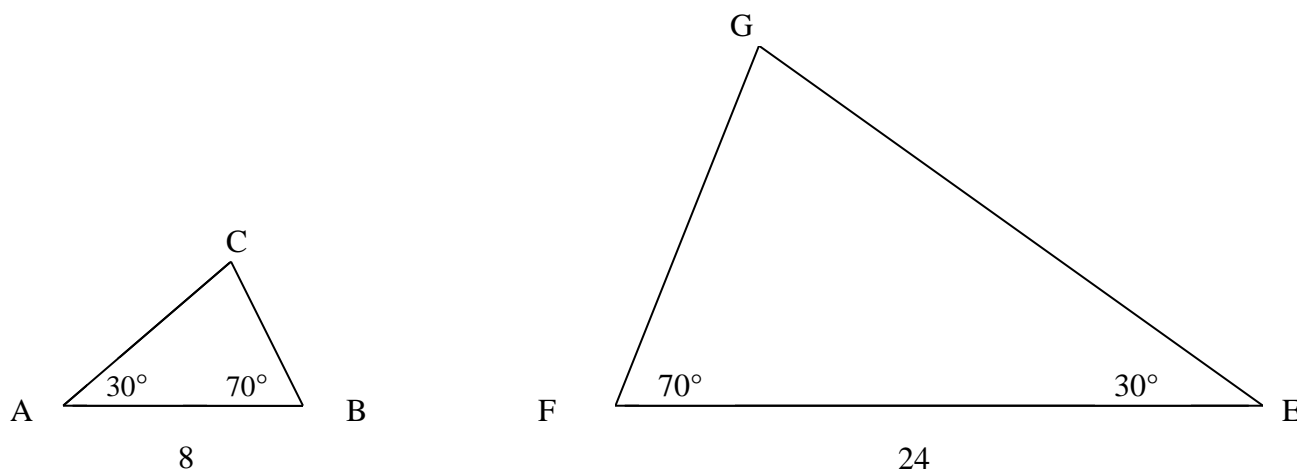

Similar Triangles

Mathematical Goals

- Discover the relationships that exist between similar figures using the scale factors, length ratios, and area ratios

STANDARDS ADDRESSED IN THIS TASK

MGSE9-12.G.SRT.1 Verify experimentally the properties of dilations given by a center and a scale factor.

- a. The dilation of a line not passing through the center of the dilation results in a parallel line and leaves a line passing through the center unchanged.
- b. The dilation of a line segment is longer or shorter according to the ratio given by the scale factor.

MGSE9-12.G.SRT.2 Given two figures, use the definition of similarity in terms of similarity transformations to decide if they are similar; explain, using similarity transformations, the meaning of similarity for triangles as the equality of all corresponding pairs of angles and the proportionality of all corresponding pairs of sides.

MGSE9-12.G.SRT.3 Use the properties of similarity transformations to establish the AA criterion for two triangles to be similar.

Standards for Mathematical Practice

- 1. Make sense of problems and persevere in solving them** by requiring students to interpret and make meaning of a problem and find a logical starting point, and to monitor their progress and change their approach to solving the problem, if necessary.
- 2. Reason abstractly and quantitatively** by requiring students to make sense of quantities and their relationships to one another in problem situations.
- 4. Model with mathematics** by expecting students to apply the mathematics concepts they know in order to solve problems arising in everyday situations, and reflect on whether the results are sensible for the given scenario.
- 8. Look for and express regularity in repeated reasoning** by expecting students to understand broader applications and look for structure and general methods in similar situations.

Georgia Department of Education
Georgia Standards of Excellence Framework
GSE Geometry • Unit 2

The sketch below shows two triangles, $\triangle ABC$ and $\triangle EFG$. $\triangle ABC$ has an area of 12 square units, and its base (AB) is equal to 8 units. The base of $\triangle EFG$ is equal to 24 units.

- a. How do you know that the triangles are similar?
- b. Name the pairs of corresponding sides and the pairs of corresponding angles. How are the corresponding sides related and how are the corresponding angles related? Why is this true?
- c. What is the area of $\triangle EFG$? Explain your reasoning.
- d. What is the relationship between the area of $\triangle ABC$ and the area of $\triangle EFG$? What is the relationship between the scale factor and the ratio of the areas of the two triangles? Use an area formula to justify your answer algebraically.

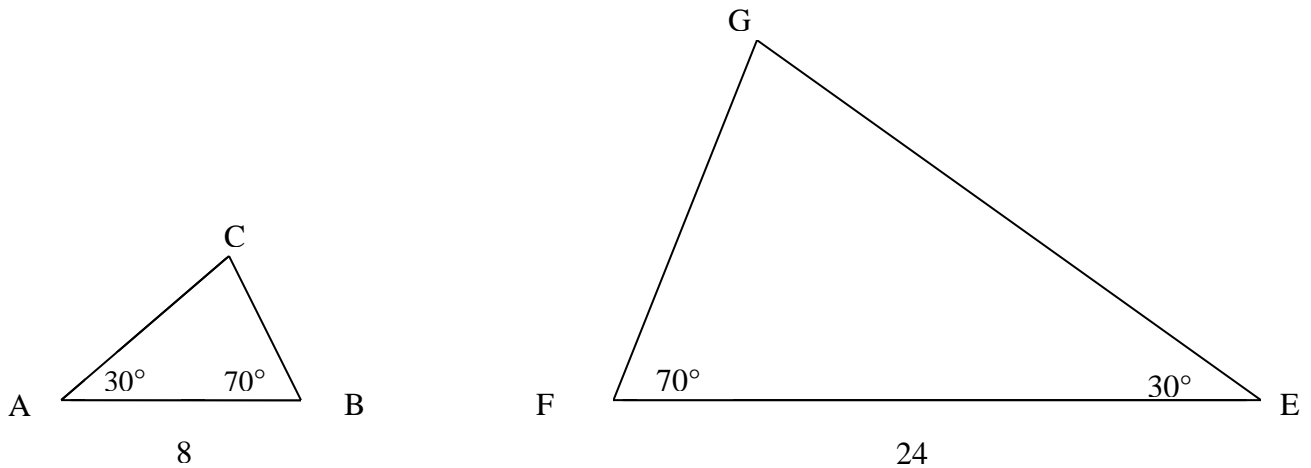

Shadow Math

Mathematical Goals

- Determine missing side lengths and areas of similar figures.

STANDARDS ADDRESSED IN THIS TASK

MGSE9-12.G.SRT.2 Given two figures, use the definition of similarity in terms of similarity transformations to decide if they are similar; explain, using similarity transformations, the meaning of similarity for triangles as the equality of all corresponding pairs of angles and the proportionality of all corresponding pairs of sides.

MGSE9-12.G.SRT.3 Use the properties of similarity transformations to establish the AA criterion for two triangles to be similar.

MGSE9-12.G.SRT.5 Use congruence and similarity criteria for triangles to solve problems and to prove relationships in geometric figures.

Standards for Mathematical Practice

- 1. Make sense of problems and persevere in solving them** by requiring students to interpret and make meaning of a problem and find a logical starting point, and to monitor their progress and change their approach to solving the problem, if necessary.
- 2. Reason abstractly and quantitatively** by requiring students to make sense of quantities and their relationships to one another in problem situations.
- 3. Construct viable arguments and critique the reasoning of others** by engaging students on discussion of why they agree or disagree with responses, decide whether they make sense, and ask useful questions to clarify or improve the arguments.
- 4. Model with mathematics** by expecting students to apply the mathematics concepts they know in order to solve problems arising in everyday situations, and reflect on whether the results are sensible for the given scenario.

Common Student Misconception

Students may incorrectly apply the scale factor. For example students will multiply instead of divide with a scale factor that reduces a figure or divide instead of multiply when enlarging a figure.

Introduction

In this task, students will determine missing side lengths of similar figures. Teachers should support good student dialogue and take advantage of comments and questions to help guide students into correct mathematical thinking.

Jeannie is practicing on the basketball goal outside her house. She thinks that the goal seems lower than the 10 ft. goal she plays on in the gym. She wonders how far the goal is from the ground. Jeannie can not reach the goal to measure the distance to the ground, but she remembers

something from math class that may help. First, she needs to estimate the distance from the bottom of the goal post to the top of the backboard. To do this, Jeannie measures the length of the shadow cast by the goal post and backboard. She then stands a yardstick on the ground so that it is perpendicular to the ground, and measures the length of the shadow cast by the yardstick. Here are Jeannie's measurements:

Length of shadow cast by goal post and backboard: 5 ft. 9 in.

Length of yardstick's shadow: 1 ft. 6 in.

Draw and label a picture to illustrate Jeannie's experiment. Using her measurements, determine the height from the bottom of the goal post to the top of the backboard.

If the goal is approximately 24 inches from the top of the backboard, how does the height of the basketball goal outside Jeannie's house compare to the one in the gym? Justify your answer.

Solution

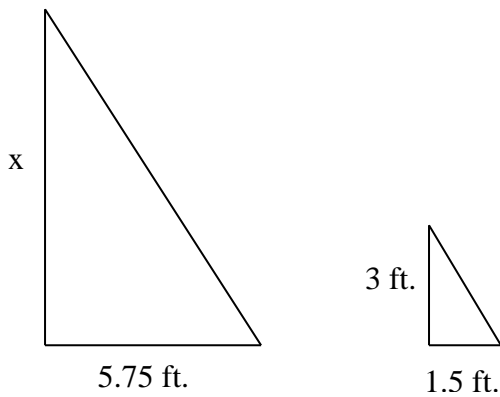

Find height of backboard, x , by solving the following proportion:

$$\frac{x}{5.75} = \frac{3}{1.5}$$

$$1.5x = 17.25$$

$$x = 17.25 \div 1.5$$
$$x = 11.5 \text{ ft.}$$

If the goal is approximately 24 inches or 2 ft. from the top of the backboard, then the height of the goal is approximately 9.5 ft. so Jeannie's goal is about 6 inches (or $\frac{1}{2}$ ft.) lower than the goal in the gym.

Solution Method 2:

Students might choose to convert all the measurements to inches.

$$\frac{x}{69} = \frac{36}{18}$$

$$18x = 2484$$

$$x = 2484 \div 18$$

$$x = 138 \text{ in. or } 11.5 \text{ ft.}$$

If the goal is approximately 24 in. or 2 ft. from the top of the backboard, then the height of the goal is approximately 114 in. or 9.5 ft., so Jeannie's goal is about 6 inches (or $\frac{1}{2}$ ft.) lower than the goal in the gym.

Shadow Math

Mathematical Goals

- Determine missing side lengths and areas of similar figures.

STANDARDS ADDRESSED IN THIS TASK

MGSE9-12.G.SRT.2 Given two figures, use the definition of similarity in terms of similarity transformations to decide if they are similar; explain, using similarity transformations, the meaning of similarity for triangles as the equality of all corresponding pairs of angles and the proportionality of all corresponding pairs of sides.

MGSE9-12.G.SRT.3 Use the properties of similarity transformations to establish the AA criterion for two triangles to be similar.

MGSE9-12.G.SRT.5 Use congruence and similarity criteria for triangles to solve problems and to prove relationships in geometric figures.

Standards for Mathematical Practice

- 1. Make sense of problems and persevere in solving them** by requiring students to interpret and make meaning of a problem and find a logical starting point, and to monitor their progress and change their approach to solving the problem, if necessary.
- 2. Reason abstractly and quantitatively** by requiring students to make sense of quantities and their relationships to one another in problem situations.
- 3. Construct viable arguments and critique the reasoning of others** by engaging students on discussion of why they agree or disagree with responses, decide whether they make sense, and ask useful questions to clarify or improve the arguments.
- 4. Model with mathematics** by expecting students to apply the mathematics concepts they know in order to solve problems arising in everyday situations, and reflect on whether the results are sensible for the given scenario.

Jeannie is practicing on the basketball goal outside her house. She thinks that the goal seems lower than the 10 ft. goal she plays on in the gym. She wonders how far the goal is from the ground. Jeannie can not reach the goal to measure the distance to the ground, but she remembers something from math class that may help. First, she needs to estimate the distance from the bottom of the goal post to the top of the backboard. To do this, Jeannie measures the length of the shadow cast by the goal post and backboard. She then stands a yardstick on the ground so that it is perpendicular to the ground, and measures the length of the shadow cast by the yardstick. Here are Jeannie's measurements:

Length of shadow cast by goal post and backboard: 5 ft. 9 in.

Length of yardstick's shadow: 1 ft. 6 in.

Georgia Department of Education
Georgia Standards of Excellence Framework
GSE Geometry • Unit 2

Draw and label a picture to illustrate Jeannie’s experiment. Using her measurements, determine the height from the bottom of the goal post to the top of the backboard.

If the goal is approximately 24 inches from the top of the backboard, how does the height of the basketball goal outside Jeannie’s house compare to the one in the gym? Justify your answer.

Proving Similar Triangles

Mathematical Goals

- Identify Similar Triangles.
- Use similarity theorems to prove that two triangles are similar.

STANDARDS ADDRESSED IN THIS TASK

MGSE9-12.G.SRT.3 Use the properties of similarity transformations to establish the AA criterion for two triangles to be similar.

Standards for Mathematical Practice

- 3. Construct viable arguments and critique the reasoning of others** by engaging students on discussion of why they agree or disagree with responses, decide whether they make sense, and ask useful questions to clarify or improve the arguments.
- 4. Model with mathematics** by expecting students to apply the mathematics concepts they know in order to solve problems arising in everyday situations, and reflect on whether the results are sensible for the given scenario.

Student Misconception

Some students often do not list the vertices of similar triangles in order. However, the order in which vertices are listed is preferred and especially important for similar triangles so that proportional sides can be correctly identified.

Introduction

This task identifies the three ways to prove that two triangles are similar by showing that they satisfy the two requirements for similar polygons. Examples and practice problems are provided.

You can always prove that two triangles are similar by showing that they satisfy the two requirements for similar polygons.

- 1.) Show that corresponding angles are congruent AND
- 2.) Show that corresponding sides are proportional.

However, there are 3 simpler methods.

Angle-Angle Similarity Postulate (AA~) If two angles of one triangle are congruent to two angles of another triangle then the triangles are similar.

Examples of AA~

The $\triangle ABC \sim \triangle XZY$ are similar by AA~ because

- 1) They are both right triangles; therefore they both have a 90 degree angle.

- 2) All triangles add up to 180 degrees, since angle C is 40 degrees in $\triangle ABC$ angle A will be 50 degrees. Therefore, $\angle A$ and $\angle X$ are congruent.

The $\triangle GHJ \sim \triangle GMK$ are similar by AA~ because

- 1) $\angle H$ and $\angle M$ are congruent by Corresponding Angles Postulate.
- 2) $\angle HGJ$ and $\angle MGK$ are congruent since they are the same angle.

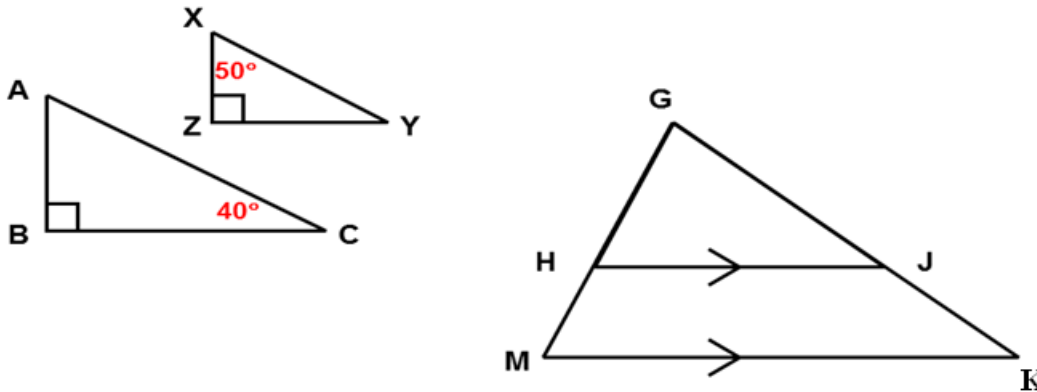

Side-Side-Side Similarity (SSS~): If the three sides of one triangle are proportional to the three sides of another triangle, then the two triangles are similar.

Example of SSS~

$\triangle FHG \sim \triangle XRS$ because three sides of one triangle are proportional to three sides of another triangle.

$$\frac{FH}{XR} = \frac{10}{16} = \frac{5}{8}$$

$$\frac{HG}{RS} = \frac{15}{24} = \frac{5}{8}$$

$$\frac{FG}{XS} = \frac{20}{32} = \frac{5}{8}$$

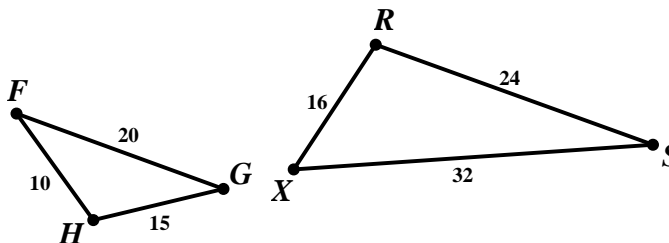

Side-Angle-Side Similarity (SAS~): If two sides of one triangle are proportional to two sides of another triangle and the included angles of these sides are congruent, then the two triangles are similar.

Example of SAS~

$\triangle RSQ \sim \triangle UST$ because

- 1) $\angle RSQ \cong \angle UST$ since Vertical Angles are Congruent
- 2) $\frac{RS}{US} = \frac{12}{9} = \frac{4}{3}$, Two sides of one triangle are proportional to two sides of another triangle.
 $\frac{SQ}{ST} = \frac{8}{6} = \frac{4}{3}$

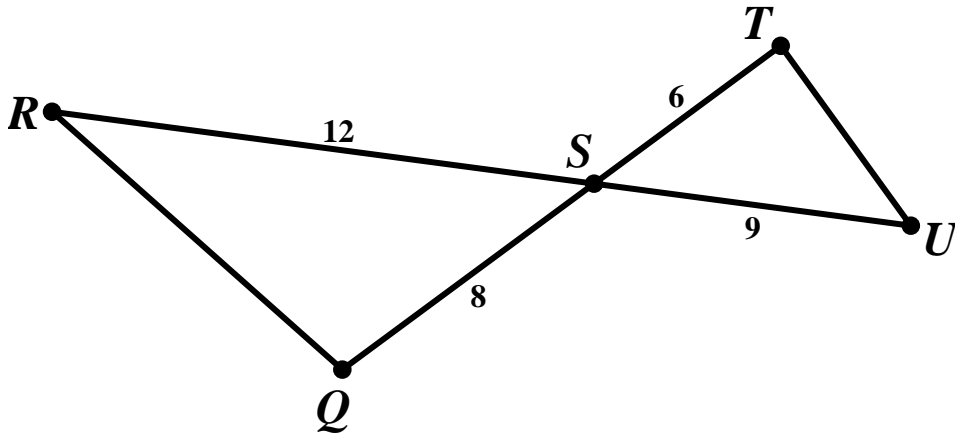

Can the two triangles shown be proved similar? If so, write a similarity statement and tell which method you used.

- 1) $\triangle AEF \sim \triangle ABC$ by AA~
- 2) Not similar
- 3) $\triangle ADC \sim \triangle BAC$ by SSS~

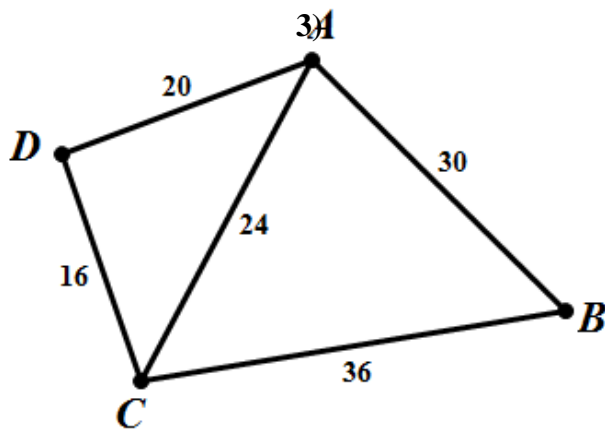
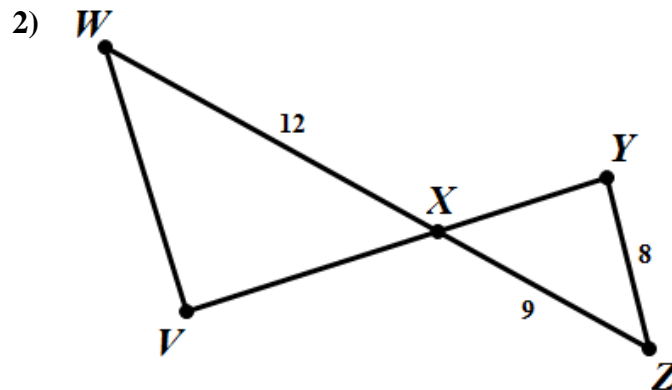
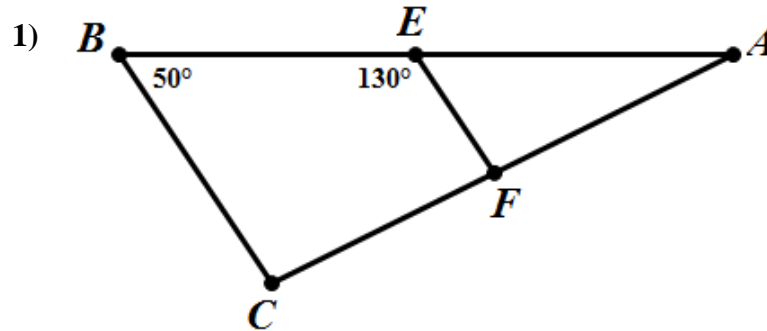

Proving Similar Triangles

Mathematical Goals

- Identify Similar Triangles.
- Use similarity theorems to prove that two triangles are similar.

STANDARDS ADDRESSED IN THIS TASK

MGSE9-12.G.SRT.3 Use the properties of similarity transformations to establish the AA criterion for two triangles to be similar.

Standards for Mathematical Practice

- 3. Construct viable arguments and critique the reasoning of others** by engaging students on discussion of why they agree or disagree with responses, decide whether they make sense, and ask useful questions to clarify or improve the arguments.
- 4. Model with mathematics** by expecting students to apply the mathematics concepts they know in order to solve problems arising in everyday situations, and reflect on whether the results are sensible for the given scenario.

Introduction

This task identifies the three ways to prove that two triangles are similar by showing that they satisfy the two requirements for similar polygons. Examples and practice problems are provided.

You can always prove that two triangles are similar by showing that they satisfy the two requirements for similar polygons.

- 1.) Show that corresponding angles are congruent AND
- 2.) Show that corresponding sides are proportional.

However, there are 3 simpler methods.

Angle-Angle Similarity Postulate (AA~) If two angles of one triangle are congruent to two angles of another triangle then the triangles are similar.

Examples of AA~

The $\triangle ABC \sim \triangle XZY$ are similar by AA~ because

- 3) They are both right triangles; therefore they both have a 90 degree angle.
- 4) All triangles add up to 180 degrees, since angle C is 40 degrees in $\triangle ABC$ angle A will be 50 degrees. Therefore, $\angle A$ and $\angle X$ are congruent.

The $\triangle GHJ \sim \triangle GMK$ are similar by AA~ because

- 3) $\angle H$ and $\angle M$ are congruent by Corresponding Angles Postulate.
- 4) $\angle HGJ$ and $\angle MGK$ are congruent since they are the same angle.

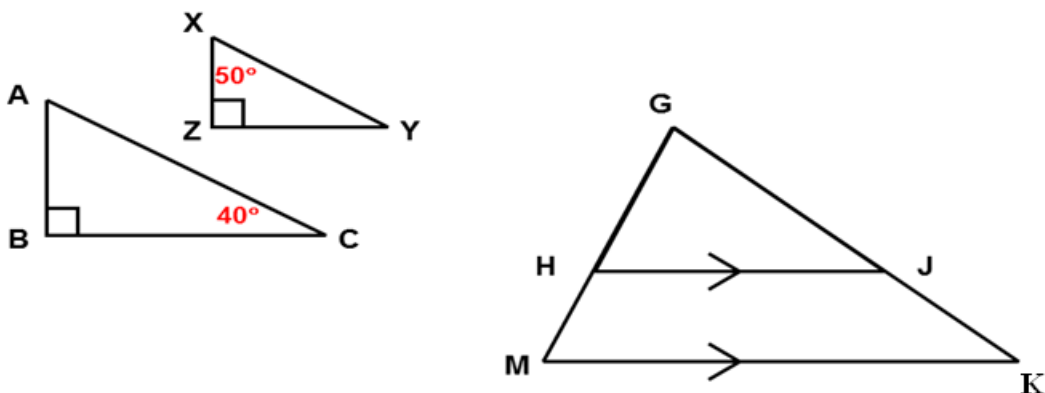

Side-Side-Side Similarity (SSS~): If the three sides of one triangle are proportional to the three sides of another triangle, then the two triangles are similar.

Example of SSS~

$\triangle FHG \sim \triangle XRS$ because three sides of one triangle are proportional to three sides of another triangle.

$$\frac{FH}{XR} = \frac{10}{16} = \frac{5}{8}$$

$$\frac{HG}{RS} = \frac{15}{24} = \frac{5}{8}$$

$$\frac{FG}{XS} = \frac{20}{32} = \frac{5}{8}$$

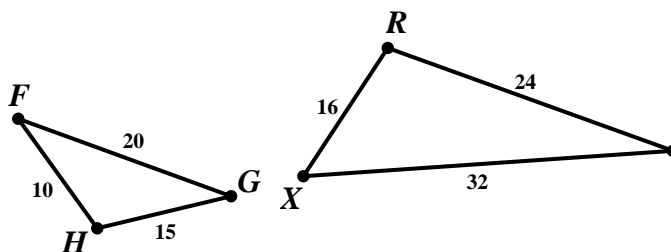

Side-Angle-Side Similarity (SAS~): If two sides of one triangle are proportional to two sides of another triangle and the included angles of these sides are congruent, then the two triangles are similar.

Example of SAS~

$\triangle RSQ \sim \triangle UST$ because

- 3) $\angle RSQ \cong \angle UST$ since Vertical Angles are Congruent
- 4) $\frac{RS}{US} = \frac{12}{9} = \frac{4}{3}$, Two sides of one triangle are proportional to two sides of another triangle.
 $\frac{SQ}{ST} = \frac{8}{6} = \frac{4}{3}$

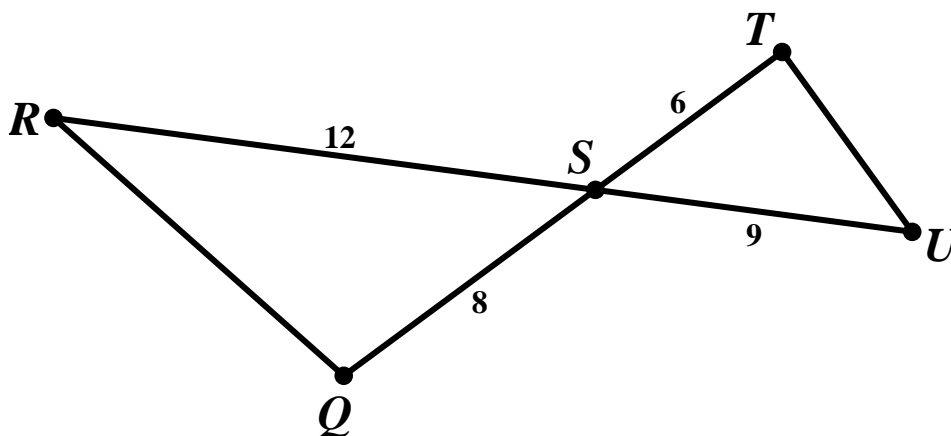

Can the two triangles shown be proved similar? If so, state the similarity and tell which method you used.

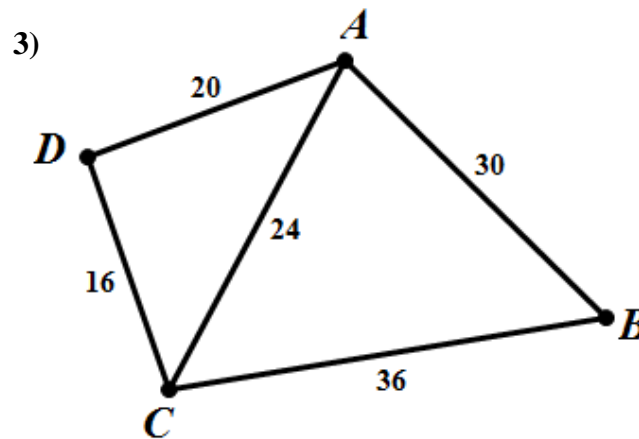
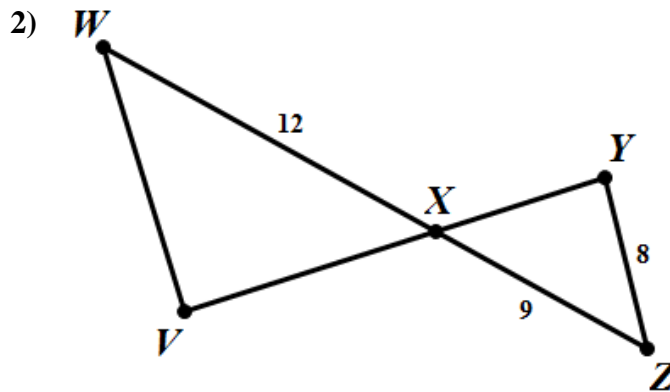
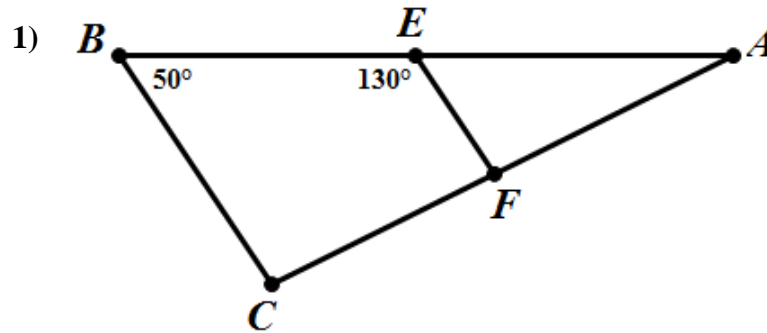

Formative Assessment Lesson: Hopewell Geometry

Source: *Balanced Assessment Materials from Mathematics Assessment Project*
<http://www.map.mathshell.org/materials/download.php?fileid=499>

ESSENTIAL QUESTION:

- How do you prove triangles are similar using the Pythagorean Theorem?

TASK COMMENTS:

Tasks and lessons from the Mathematics Assessment Project are specifically designed to help teachers effectively formatively assess their students. The way the tasks and lessons are designed gives the teacher a clear understanding of what the students are able to do and not do. Within the lesson, teachers will find suggestions and question prompts that will help guide students towards understanding. For more information access the MAP website:

<http://www.map.mathshell.org/materials/background.php?subpage=summative>

The task, *Hopewell Geometry*, is a Mathematics Assessment Project Assessment Task that can be found at the

website: <http://www.map.mathshell.org/materials/tasks.php?taskid=127&subpage=apprentice>

The PDF version of the task can be found at the link below:

<http://www.map.mathshell.org/materials/download.php?fileid=499>

The scoring rubric can be found at the following link:

<http://www.map.mathshell.org/materials/download.php?fileid=500>

STANDARDS ADDRESSED IN THIS TASK:

Prove theorems involving similarity

MGSE9-12.G.SRT.4 Prove theorems about triangles. Theorems include: a line parallel to one side of a triangle divides the other two proportionally, (and its converse); the Pythagorean Theorem using triangle similarity.

MGSE9-12.G.SRT.5 Use congruence and similarity criteria for triangles to solve problems and to prove relationships in geometric figures.

Standards for Mathematical Practice

This task uses all of the practices with emphasis on:

- 3. Construct viable arguments and critique the reasoning of others** by engaging students on discussion of why they agree or disagree with responses, decide whether they make sense, and ask useful questions to clarify or improve the arguments.

7. Look for and make use of structure by expecting students to apply rules, look for patterns and analyze structure.

Pythagorean Theorem using Triangle Similarity

Mathematical Goals

- Prove the Pythagorean Theorem using triangle similarity.

STANDARDS ADDRESSED IN THIS TASK

MGSE9-12.G.SRT.4 Prove theorems about triangles. Theorems include: a line parallel to one side of a triangle divides the other two proportionally, (and its converse); the Pythagorean Theorem using triangle similarity.

Standards for Mathematical Practice

1. **Make sense of problems and persevere in solving them** by requiring students to interpret and make meaning of a problem and find a logical starting point, and to monitor their progress and change their approach to solving the problem, if necessary.
2. **Reason abstractly and quantitatively** by requiring students to make sense of quantities and their relationships to one another in problem situations.
3. **Construct viable arguments and critique the reasoning of others** by engaging students on discussion of why they agree or disagree with responses, decide whether they make sense, and ask useful questions to clarify or improve the arguments.
4. **Model with mathematics** by expecting students to apply the mathematics concepts they know in order to solve problems arising in everyday situations, and reflect on whether the results are sensible for the given scenario.
5. **Use appropriate tools strategically** by expecting students to consider available tools when solving a mathematical problem. These tools might include pencil and paper, concrete models, a ruler, a protractor, a compass, a calculator, software, etc.
6. **Attend to precision** by requiring students to calculate efficiently and accurately; and to communicate precisely with others by using clear mathematical language to discuss their reasoning.
7. **Look for and make use of structure** by expecting students to apply rules, look for patterns and analyze structure.
8. **Look for and express regularity in repeated reasoning** by expecting students to understand broader applications and look for structure and general methods in similar situations.

Common Student Misconception

Some students may confuse the Pythagorean Theorem and its converse.

Introduction

This task has students use cardboard cutouts to illustrate that the altitude to the hypotenuse divides a right triangle into two triangles that are similar to the original triangle. Then use AA to prove this theorem. Then, use this result to establish the Pythagorean relationship among the sides of a right triangle ($a^2 + b^2 = c^2$) and thus obtain an algebraic proof of the Pythagorean Theorem.

Materials

- Cardboard
- Straightedge

Use cardboard cutouts to illustrate the following investigation:

In the next figure, draw triangle ABC as a right triangle. Its right angle is angle C.

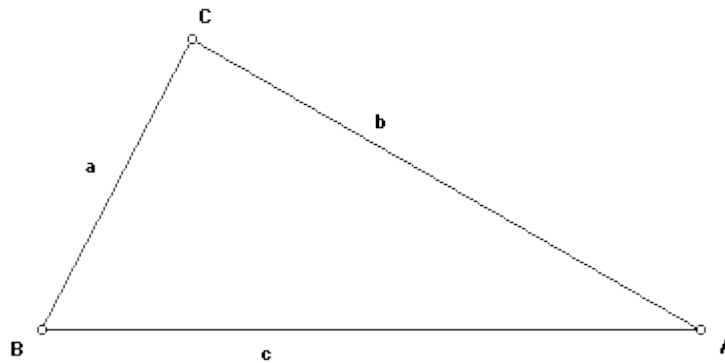

Next, draw CD perpendicular to AB as shown in the next figure.

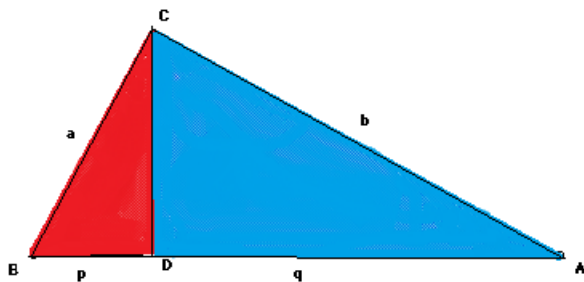

How many triangles do you see in the figure? **3**

Why are the three triangles similar to each other? **AA~**

Compare triangles 1 and 3:

Triangle 1 (green) is the right triangle that we began with prior to constructing CD. Triangle 3 (blue) is one of the two triangles formed by the construction of CD.

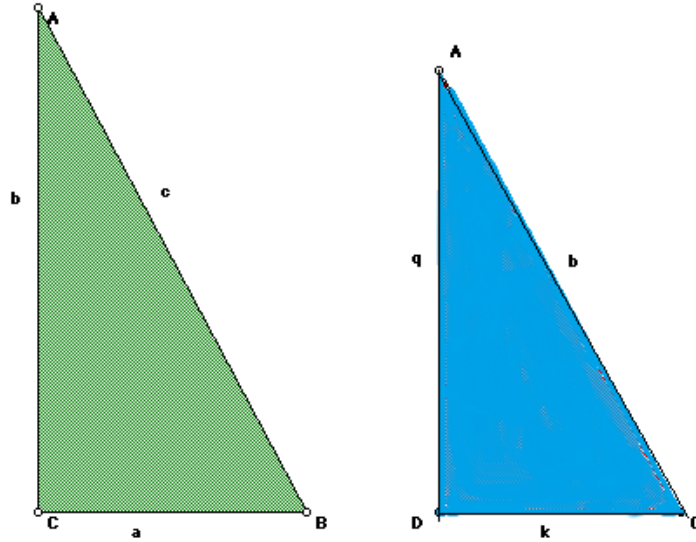

By comparing these two triangles, we can see that $\frac{c}{b} = \frac{b}{q}$ and $b^2 = cq$

Compare triangles 1 and 2:

Triangle 1 (green) is the same as above. Triangle 2 (red) is the other triangle formed by constructing CD. Its right angle is angle D.

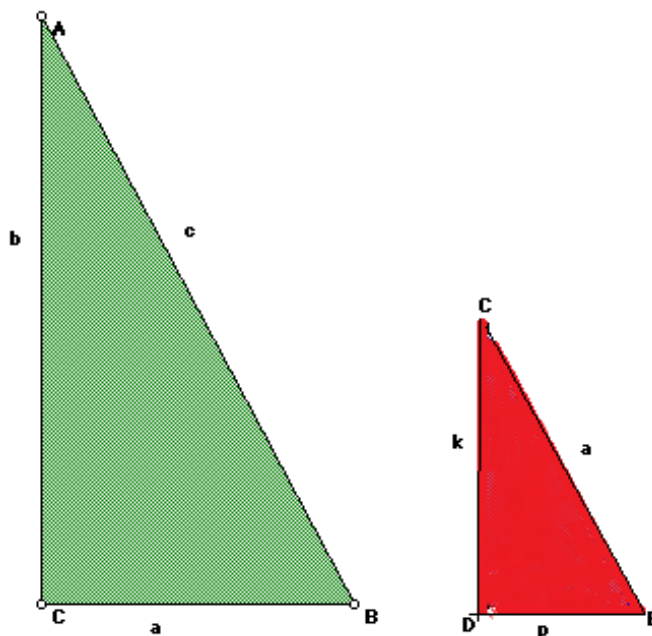

By comparing these two triangles, we see that $\frac{c}{a} = \frac{a}{p}$ and $a^2 = cp$

By adding the two equations:

$$\begin{aligned} a^2 + b^2 &= cp + cq \\ a^2 + b^2 &= c(p + q) \end{aligned}$$

CD, we have that $(p + q) = c$. By substitution, we get

$$a^2 + b^2 = c^2$$

Pythagorean Theorem using Triangle Similarity

Mathematical Goals

- Prove the Pythagorean Theorem using triangle similarity.

STANDARDS ADDRESSED IN THIS TASK

MGSE9-12.G.SRT.4 Prove theorems about triangles. Theorems include: a line parallel to one side of a triangle divides the other two proportionally, (and its converse); the Pythagorean Theorem using triangle similarity.

Standards for Mathematical Practice

- 1. Make sense of problems and persevere in solving them** by requiring students to interpret and make meaning of a problem and find a logical starting point, and to monitor their progress and change their approach to solving the problem, if necessary.
- 2. Reason abstractly and quantitatively** by requiring students to make sense of quantities and their relationships to one another in problem situations.
- 3. Construct viable arguments and critique the reasoning of others** by engaging students on discussion of why they agree or disagree with responses, decide whether they make sense, and ask useful questions to clarify or improve the arguments.
- 4. Model with mathematics** by expecting students to apply the mathematics concepts they know in order to solve problems arising in everyday situations, and reflect on whether the results are sensible for the given scenario.
- 5. Use appropriate tools strategically** by expecting students to consider available tools when solving a mathematical problem. These tools might include pencil and paper, concrete models, a ruler, a protractor, a compass, a calculator, software, etc.
- 6. Attend to precision** by requiring students to calculate efficiently and accurately; and to communicate precisely with others by using clear mathematical language to discuss their reasoning.
- 7. Look for and make use of structure** by expecting students to apply rules, look for patterns and analyze structure.
- 8. Look for and express regularity in repeated reasoning** by expecting students to understand broader applications and look for structure and general methods in similar situations.

Introduction

This task has students use cardboard cutouts to illustrate that the altitude to the hypotenuse divides a right triangle into two triangles that are similar to the original triangle. Then use AA to prove this theorem. Then, use this result to establish the Pythagorean relationship among the sides of a right triangle ($a^2 + b^2 = c^2$) and thus obtain an algebraic proof of the Pythagorean Theorem.

Materials

- Cardboard
- Straightedge

Use cardboard cutouts to illustrate the following investigation:

In the next figure, draw triangle ABC as a right triangle. Its right angle is angle C.

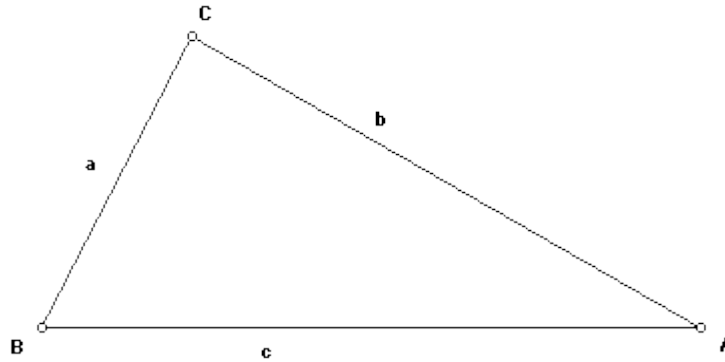

Next, draw CD perpendicular to AB as shown in the next figure.

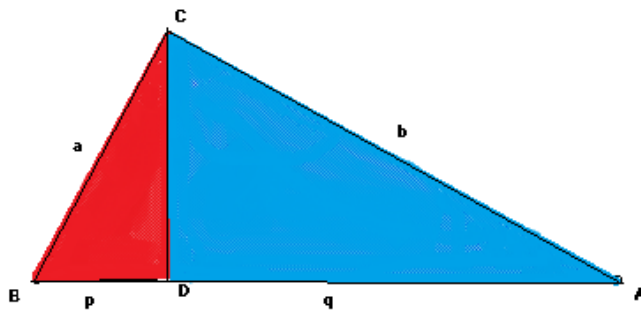

How many triangles do you see in the figure?

Why are the three triangles similar to each other?

Compare triangles 1 and 3:

Triangle 1 (green) is the right triangle that we began with prior to constructing CD. Triangle 3 (blue) is one of the two triangles formed by the construction of CD.

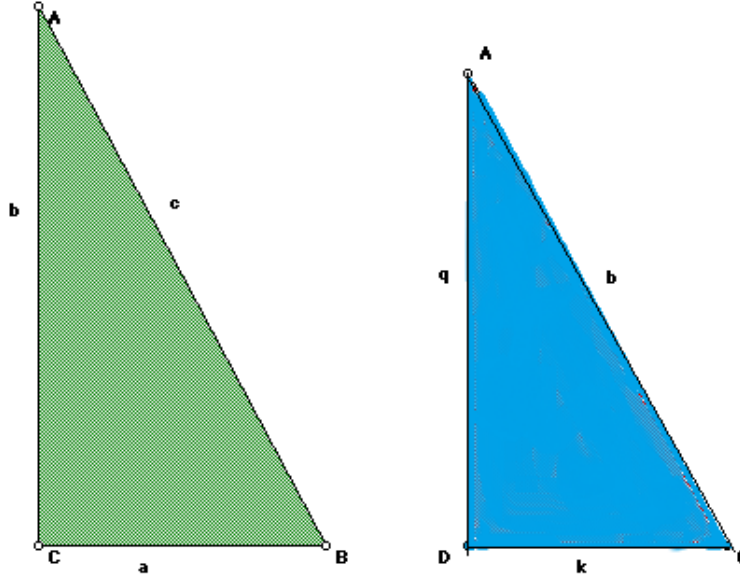

By comparing these two triangles, we can see that $\frac{c}{b} = \frac{b}{q}$ and $b^2 = cq$

Compare triangles 1 and 2:

Triangle 1 (green) is the same as above. Triangle 2 (red) is the other triangle formed by constructing CD. Its right angle is angle D.

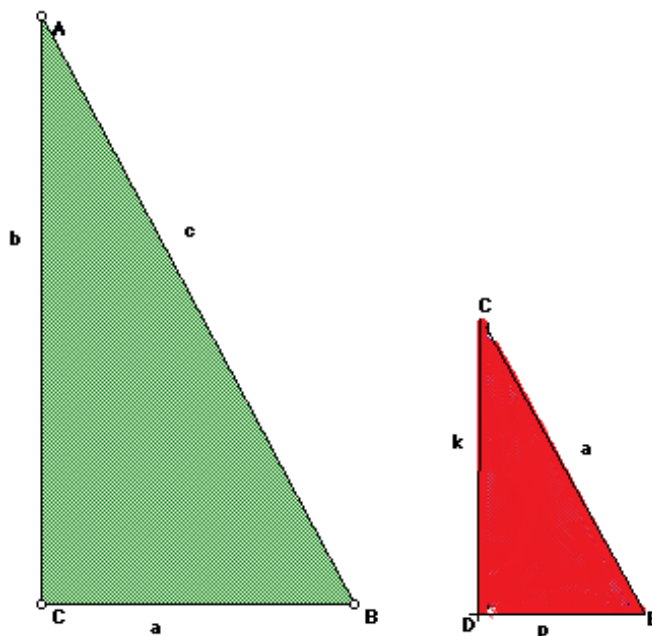

By comparing these two triangles, we see that $\frac{c}{a} = \frac{a}{p}$ and $a^2 = cp$

By adding the two equations:

$$\begin{aligned} a^2 + b^2 &= cp + cq \\ a^2 + b^2 &= c(p + q) \end{aligned}$$

CD, we have that $(p + q) = c$. By substitution, we get

$$a^2 + b^2 = c^2$$

Formative Assessment Lesson: Solving Geometry Problems - Floodlights

Source: *Formative Assessment Lesson Materials from Mathematics Assessment Project*
<http://map.mathshell.org/materials/download.php?fileid=1257>

ESSENTIAL QUESTION:

- How do you make a mathematical model for similar triangles to solve problems?

TASK COMMENTS:

Tasks and lessons from the Mathematics Assessment Project are specifically designed to help teachers effectively formatively assess their students. The way the tasks and lessons are designed gives the teacher a clear understanding of what the students are able to do and not do. Within the lesson, teachers will find suggestions and question prompts that will help guide students towards understanding. For more information access the MAP website:

<http://www.map.mathshell.org/materials/background.php?subpage=formative>

The task, *Solving Geometry Problems: Floodlights*, is a Formative Assessment Lesson (FAL) that can be found at the website:

<http://map.mathshell.org/materials/lessons.php?taskid=429&subpage=problem>

The FAL document provides a clear lesson design, from the opening of the lesson to the closing of the lesson.

The PDF version of the task can be found at the link below:

<http://map.mathshell.org/materials/download.php?fileid=1257>

STANDARDS ADDRESSED IN THIS TASK:

Prove theorems involving similarity

MGSE9-12.G.SRT.4 Prove theorems about triangles. Theorems include: a line parallel to one side of a triangle divides the other two proportionally, (and its converse); the Pythagorean Theorem using triangle similarity.

MGSE9-12.G.SRT.5 Use congruence and similarity criteria for triangles to solve problems and to prove relationships in geometric figures.

Prove geometric theorems

MGSE9-12.G.CO.9 Prove theorems about lines and angles. Theorems include: vertical angles are congruent; when a transversal crosses parallel lines, alternate interior angles are congruent and corresponding angles are congruent; points on a perpendicular bisector of a line segment are exactly those equidistant from the segment's endpoints.

MGSE9-12.G.CO.10 Prove theorems about triangles. Theorems include: measures of interior angles of a triangle sum to 180 degrees; base angles of isosceles triangles are congruent; the segment joining midpoints of two sides of a triangle is parallel to the third side and half the length; the medians of a triangle meet at a point.

MGSE9-12.G.CO.11 Prove theorems about parallelograms. Theorems include: opposite sides are congruent, opposite angles are congruent, the diagonals of a parallelogram bisect each other, and conversely, rectangles are parallelograms with congruent diagonals.

Standards for Mathematical Practice

This lesson uses all of the practices with emphasis on:

- 1. Make sense of problems and persevere in solving them** by requiring students to interpret and make meaning of a problem and find a logical starting point, and to monitor their progress and change their approach to solving the problem, if necessary.
- 2. Reason abstractly and quantitatively** by requiring students to make sense of quantities and their relationships to one another in problem situations.
- 4. Model with mathematics** by expecting students to apply the mathematics concepts they know in order to solve problems arising in everyday situations, and reflect on whether the results are sensible for the given scenario.
- 5. Use appropriate tools strategically** by expecting students to consider available tools when solving a mathematical problem. These tools might include pencil and paper, concrete models, a ruler, a protractor, a compass, a calculator, software, etc.
- 7. Look for and make use of structure** by expecting students to apply rules, look for patterns and analyze structure.

Culminating Task: Geometry Gardens

Adapted from <https://sites.google.com/site/eidsonmath1/home/geometry-gallery>. Retrieved on: Tuesday, June 6th, 2013.

Mathematical Goals

- Mathematicians recognize congruence of plane figures and are able to prove congruence using geometric theorems.
- Congruence of plane figures can be verified through rigid motions.
- Congruence can be used to solve problems and prove geometric relationships.

STANDARDS ADDRESSED IN THIS TASK

MGSE9-12.G.SRT.5 Use congruence and similarity criteria for triangles to solve problems and to prove relationships in geometric figures.

MGSE9-12.G.CO.6 Use geometric descriptions of rigid motions to transform figures and to predict the effect of a given rigid motion on a given figure; given two figures, use the definition of congruence in terms of rigid motions to decide if they are congruent.

MGSE9-12.G.CO.7 Use the definition of congruence in terms of rigid motions to show that two triangles are congruent if and only if corresponding pairs of sides and corresponding pairs of angles are congruent.

MGSE9-12.G.CO.9 Prove theorems about lines and angles. Theorems include: vertical angles are congruent; when a transversal crosses parallel lines, alternate interior angles are congruent and corresponding angles are congruent; points on a perpendicular bisector of a line segment are exactly those equidistant from the segment's endpoints.

MGSE9-12.G.CO.10 Prove theorems about triangles. Theorems include: measures of interior angles of a triangle sum to 180 degrees; base angles of isosceles triangles are congruent; the segment joining midpoints of two sides of a triangle is parallel to the third side and half the length; the medians of a triangle meet at a point.

Standards for Mathematical Practice

- 1. Make sense of problems and persevere in solving them** by requiring students to interpret and make meaning of a problem and find a logical starting point, and to monitor their progress and change their approach to solving the problem, if necessary.
- 2. Reason abstractly and quantitatively** by requiring students to make sense of quantities and their relationships to one another in problem situations.
- 3. Construct viable arguments and critique the reasoning of others** by engaging students on discussion of why they agree or disagree with responses, decide whether they make sense, and ask useful questions to clarify or improve the arguments.

4. **Model with mathematics** by expecting students to apply the mathematics concepts they know in order to solve problems arising in everyday situations, and reflect on whether the results are sensible for the given scenario.
5. **Use appropriate tools strategically** by expecting students to consider available tools when solving a mathematical problem. These tools might include pencil and paper, concrete models, a ruler, a protractor, a compass, a calculator, software, etc.
6. **Attend to precision** by requiring students to calculate efficiently and accurately; and to communicate precisely with others by using clear mathematical language to discuss their reasoning.
7. **Look for and make use of structure** by expecting students to apply rules, look for patterns and analyze structure.
8. **Look for and express regularity in repeated reasoning** by expecting students to understand broader applications and look for structure and general methods in similar situations.

Introduction

This task asks students to visualize geometric shapes, identify plane figures and their attributes, prove triangles are congruent, determine the area of quadrilaterals, make geometric conjectures and justify geometric arguments.

The culminating task is based on the properties of triangles and quadrilaterals. You will create a map or illustration that encompasses the new properties that we have learned. Your map or illustration must include the following items:

- At least one example of a triangle inequality
- At least one set of congruent triangles
- At least one specific type of quadrilateral

For your map or illustration you will submit your visual AND an explanation for the map or illustration that includes an explanation/justification for why the geometric shapes or properties are useful and how it is related to the context of your map or illustration. Let the Culminating Task Rubric guide your work. If you need additional guidance, refer to the Culminating Task example.

This task may be completed using computer software or by hand on paper. As always, please ask any questions that may come up along the way, and do your best.

Possible Materials

- graph paper
- compass
- straightedge
- Geometry software

Culminating Task Example:

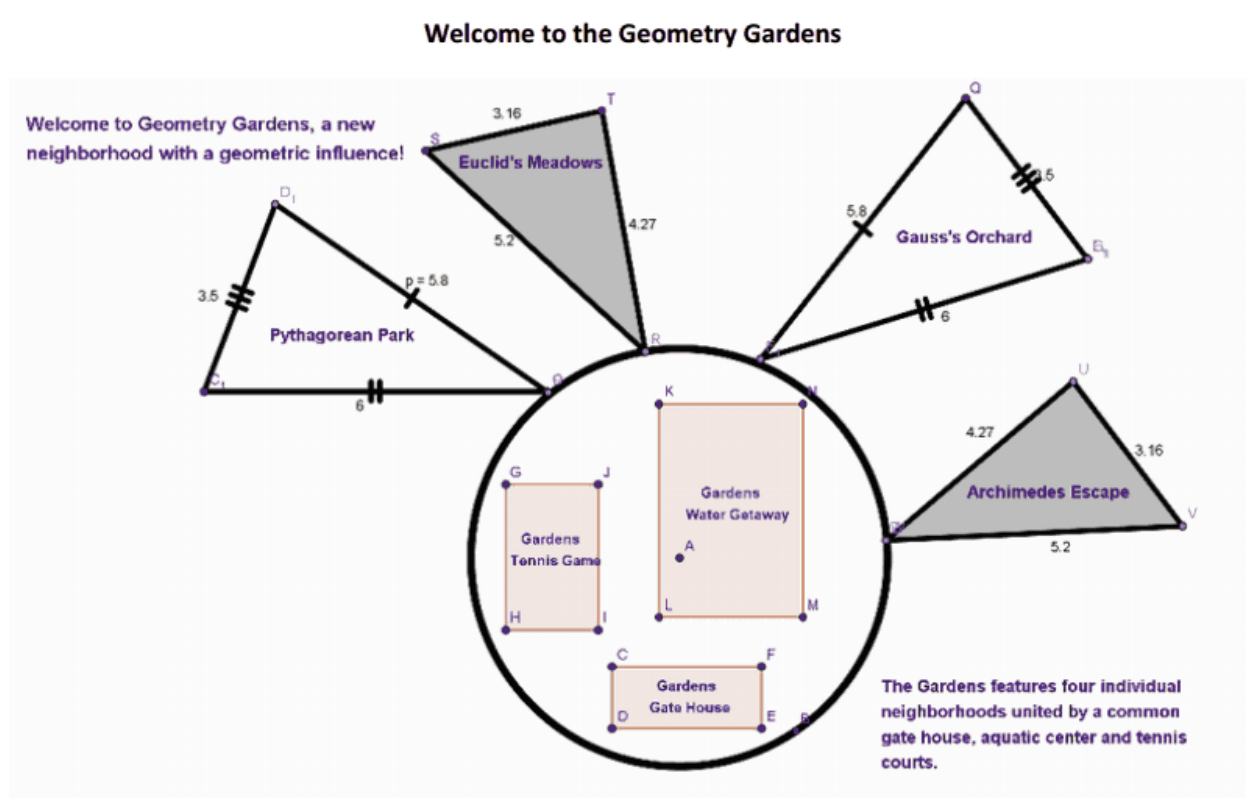

The Geometry Gardens is a neighborhood laid out with geometry in mind. The four individual neighborhoods are in the shape of a triangle with Pythagorean Park and Gauss’s Orchard being congruent and Euclid’s Meadows and Archimedes’ Escape also congruent. These triangles were made congruent to assist in the measurements that are needed in constructing the roads. Also since each house will sit on a one acre plot, using congruent triangle will mean that calculations for the number of houses that can be built will only need to be made twice, once for each of the different triangles. The planning of the Gardens has also made use of the side-angle inequality. Since the developers wanted the least number of houses on the side of the triangle furthest from the common amenities, that road must be the shortest, thus the angle at the front of the smaller neighborhoods must be the smallest. While both the Gardens Gate House and the Gardens Water Getaway are quadrilaterals, the Gardens Tennis Game is the most specific quadrilateral, being a rectangle. This amenity will include two standard sized tennis courts with a 5 foot walkway around both courts. Since the courts will be congruent with the same size walkway around them, the opposite sides will be congruent to each other. Also since the corners of the courts form a 90° angle, the same angle will be formed by the walkway, creating a rectangular tennis amenity. The developers of the Geometry Gardens sincerely hope you enjoy the home and lifestyle you find here.

Georgia Department of Education
 Georgia Standards of Excellence Framework
GSE Geometry • Unit 2

Sample Rubric for Culminating Task:

Map Culminating Task Rubric					
	5	4	3	2	1
Congruent Triangles	Congruent triangles are present in the map with an explanation for why congruent triangles are useful in the context of the map or illustration.	Congruent triangles are present with an explanation for why the triangles are useful only loosely tied to the context of the map or illustration.	Triangles are present with no proof that they are congruent although an explanation for their use that is relevant to the context is present.	Triangles are present with no proof that they are congruent with an explanation for their use only loosely tied to the context.	Triangles are present with no proof that they are congruent with no explanation for their use.
Triangle Inequalities	At least one example of a triangle inequality is present in the map or illustration with an explanation for the inequality's usefulness in the context of the map or illustration.	A triangle inequality is present with an explanation for why the inequality is useful only loosely tied to the context of the map or illustration.	A triangle inequality is present but with no proof of it with an explanation for the inequality's usefulness in the context of the map or illustration.	A triangle inequality is present but with no proof of it with an explanation that is only loosely tied to the context of the map or illustration.	A triangle inequality is present but with no proof of it with no explanation of its use.
Quadrilateral	At least one example of a specific quadrilateral is present in the map or illustration with an explanation for its usefulness in the context of the map or illustration.	A specific quadrilateral is present with an explanation for why the quadrilateral is useful only loosely tied to the context of the map or illustration.	A specific quadrilateral is present but with no specifics sited to determine the type of quadrilateral. The explanation for its usefulness is in the context of the map or illustration.	A specific quadrilateral is present but with no specifics sited to determine the type of quadrilateral. The explanation for its usefulness is only loosely tied to the context.	A specific quadrilateral is present but with no specifics sited to determine the type of quadrilateral. There is no explanation for the quadrilateral.
Presentation	The map or illustration has a cohesive theme, is neatly done and makes use of the various geometric shapes and properties we have learned.	The map or illustration has a cohesive theme, is neatly done and makes use of most of the various geometric shapes and properties we have learned.	The map or illustration has a cohesive theme, is neatly done and makes use of some of the geometric shapes and properties we have learned.	The map or illustration has a cohesive theme, is not neatly done and makes use of only some of the geometric shapes and properties we have learned.	The map or illustration has no cohesive theme, is not neatly done and makes use of only some of the geometric shapes and properties we have learned.